

NEW

PROTEUS

65p

12! 1

A Complete Fantasy Adventure Game Magazine



**CAN YOU DEFEAT THE RULER OF
THE TOWER OF TERROR?**

Australia \$1.95 New Zealand \$2.50 Malaysia \$3.95

DE-LEUW 84

DICE and a pencil are all you need to begin this adventure – then you decide which route to take, which dangers to brave.

As you progress through the Tower of Terror, you are likely to encounter various traps, or face monsters. You will also get information, or find certain items which will be of help to you in your quest. You should record these in your *quest sheet* as well as keeping an account of how many rations you have left, and which Potions you have. As you use up rations, or take Potions, remember to cross them off in your *quest sheet*.

It is important that you build up a map of the way to the very top of the Tower. You may not succeed at your first attempt, but each new journey will give you more information – until you are at last successful in your quest.

If you try to read the magazine in numerical order, it will make no sense. You must choose, when you are given the choice, which section to turn to, and which traps, puzzles, or monsters to face. Good luck!

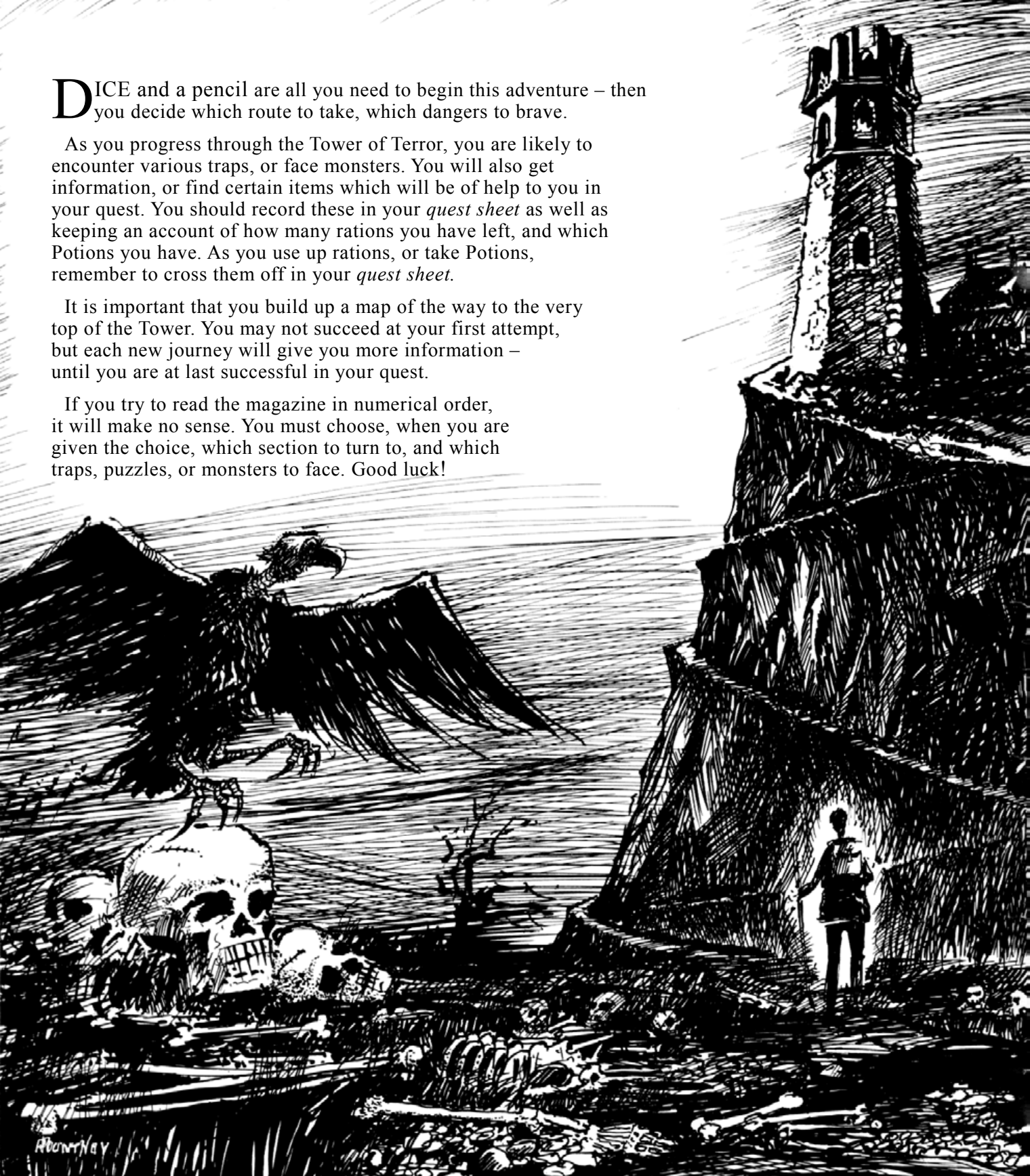

FRONT COVER: Dave De Leuw

ILLUSTRATIONS BY: Jack Pountney; John Pickering; Alan Hunter; Dave Scammell

© IPC Magazines Limited 1984. Copyright in all drawings and material published in Proteus is fully protected and reproductions or imitations in whole or part are expressly forbidden. Whilst every care is taken in preparing these games we cannot accept any responsibility for error. Published on approximately the 14th of the month by IPC Magazines Limited, Westover House, West Quay Road, Poole, Dorset BH15 1JG. Printed in England by Chapel River Press, Andover, Hants. Sole Agents for Australia and New Zealand Gordon and Gotch (Asia) Ltd.; South Africa Central News Agency Ltd. Proteus is sold subject to the following conditions, namely that it shall not, without the written consent of the Publishers first having been given, be lent, resold, hired out or otherwise disposed of by way of Trade at more than the recommended selling price shown on the cover, and that it shall not be lent, resold, hired out or otherwise disposed of in a mutilated condition or in any unauthorised cover by way of Trade or affixed to or as part of any publication or advertising, literary or pictorial matter whatsoever.

THE TOWER OF TERROR

by
David Brunskill



INTRODUCTION

IN THIS ADVENTURE, you are at the Academy of the Grand Wizard Eleutheria. Although he has taught you a great deal about the martial arts, the use of magic, and the power of reason, he tells you that you have not yet learnt enough.

But you long to be free of the stifling, safe Academy; to try out for yourself the skills you have learned. Your restlessness increases; you wish to make your own way in the world. You think about leaving, walking the dark lanes, challenging anyone who threatens you. You will be alone. There will be no-one to guide you.

In this adventure, only your own Dexterity, Strength, and Courage may see you through. Below, you will discover – with a little luck – how swift, strong and brave you are.

You will need two dice, a pencil, and several sheets of paper. Use the pencil and paper to draw a map of your progress through the Tower of Terror – you may not succeed at your first attempt, and the map will be useful in future attempts.

Dexterity, Strength, and Courage

Roll one dice. Add 8 to this number, and make a note of it on your Quest Sheet. This is your *Dexterity* score: a measure of your swordsmanship and agility.

Roll two dice. Add 15 to this number. This is your *Strength* score. Make a note of it on your Quest Sheet. This is a measure of your fitness, stamina, and prowess in battle.

Roll one dice. Add 6. This is your *Courage* score – make a record of it on your Quest Sheet. It is a measure, as the name suggests, of your bravery in the face of danger.

These *Initial* scores may never be exceeded. They will change during the course of an adventure – sometimes you will lose points, sometimes win them – but the *Initial* levels, determined by the dice rolls, are the maximum allowed for any particular adventure.

Rules for fighting

As you progress in your quest, you will often have to fight creatures of some sort. Each

creature will have its own Dexterity and Strength score, given in the text. Make a note of these when you meet the creature.

To resolve a battle:

1. Roll two dice, and add the creature's current Dexterity score. This is its *Fighting Power*.

2. Roll two dice, and add your own current Dexterity score. This is your *Fighting Power*.

3. If your *Fighting Power* is greater than the creature's, you have scored a blow with your sword and wounded it. Subtract two Strength points from its Strength score at that moment. If the creature's *Fighting Power* is greater than yours in this round, it has wounded you. Subtract two points from your current Strength score.

If both scores are the same, you have parried each other's blows, and neither of you lose any points.

The next round in the battle is done in just the same way. You repeat 1, 2, and 3 above. When either your or the creature's Strength score is reduced to zero, the battle is over. A zero Strength score means death.

Losing and gaining points.

In some sections, you will be awarded extra points. (For example, you may read, "Gain 2 Strength and 2 Courage points.") You add these to your current Strength and Courage scores: but remember, these scores may never exceed their *Initial* values. When you lose points (for example, "Lose 1 Dexterity point and 2 Courage points."), you simply deduct these from your current scores.

Replenishing your Strength

You take with you enough food and drink for *five* meals. Make a note of these rations on your Quest Sheet. You may stop for a meal at any time during your adventure, except during a battle. Eating a meal restores 5 Strength points.

When you stop for a meal, add 5 points to your current Strength score and deduct one from the number of rations remaining to you.

Quest Sheet

**Dexterity
Score**

**Strength
Score**

**Courage
Score**

Rations

Potions

Secrets Learnt

Items Discovered



THE JOURNEY BEGINS

In your fourth year at the Academy of the Grand Wizard Eleutheria, you are becoming bored. You have learned a great deal of magic, of the power of reason, and the martial arts. Now you yearn for a challenge. But Eleutheria warns you that unless you stay for your fifth and final year, you will not be fully proficient in the arts of fighting, reason, and magic, and will be vulnerable to evil forces.

However, you are adamant: you have spent almost four years learning your skills, and are acknowledged as the finest magician, best thinker, and toughest fighter.

“This is true,” says Eleutheria. “But you still have much to learn. Especially, you must know how to decide whether reason, magic, or force is the best course to take.”

But the prospect of another year in the Academy is too much for you, and you decide to leave. That night, you pack your book of spells, enough food and drink for five meals, and then look around the room you have lived in for the past four years. It is more like a cell than a room. You have had a stone bed to lie on, and a Wizard’s dummy to practise your sword-skills and Martial Arts against.

You reconsider: are you really going to leave the security of the Academy? And where would you go? You have heard stories of the town of Darkblood, to the East, apparently ruled over by a great but very evil Wizard.

You recall that Eleutheria had spoken briefly only once about this Wizard, saying that he was powerful and terrible, and almost the equal of Eleutheria himself. For the Ruler of Darkblood had once been one of the Grand Wizards, but had been exiled when he used his magic and power to plunder whole townships and steal treasure.

You go into the cell opposite, where your friend Leofric is sitting on his bed, apparently lost in thought. You know that he too has been restless, and tell him that you are going to leave that night in search of adventure. You ask if he will accompany you.

At first he is enthusiastic, but then he has second thoughts: “We would be alone, in strange territory,” he says. “And as for Darkblood – there are rumours of adventurers being buried alive or boiled in oil for even daring to go there. We should at least wait until Eleutheria has taught us all he can. One day perhaps,” he says, “but not yet.”

You leave him in his cell with his dreams and his fears, and walk back into your own room. You will have to leave alone.

The idea in your mind becomes more exciting – to journey to Darkblood. You wonder what you will find there. There are certainly stories of the Ruler’s horrible vengeance against those who have opposed him, and you are far from sure that your own Powers are enough yet to be a match for him. You are strong; you have your Book of Spells – but you know that, because of your inexperience, your Spells do not always work.

However – the Magical potions kept in the basement do always work in your experience. You quickly decide that if you are to have any chance against the Ruler of Darkblood, you will need some Potions.

You creep down into the basement and look at the bottles of Magic neatly arranged in an alcove at the back. At first, you try to put as many as you can into your backpack. But then there is no room for your food and drink. After packing and repacking several times, you realise that you will have to be selective. Only six Potions of Magic will fit into your backpack. Choose any six different Potions.

1. Truth-seeking: You will know when someone is lying to you.

2. Searching: Will take you in the right direction when you are faced with a choice.

3. Transparency: Enables you to disappear, like a ghost.

4. Invincibility: Not quite as powerful as it sounds! It will totally protect you against any creature only for the first *three* rounds of fighting (See Rules for Fighting). This means

you will lose no Strength points for the first three times you are wounded in that battle.

5. Flying: You will float over any natural obstacle.

6. Power: Each blow in any one battle will cause four Strength points to be lost by the enemy for the first two rounds of fighting (See Rules for Fighting).

7. Calm: Will restore your Courage points to their Initial level.

8. Fear: Any enemy will lose *three* Dexterity points for that particular battle (See Rules for Fighting).

9. Intuition: You will know the answer to a question, without necessarily knowing why.

10. Duality: An enemy will actually fight someone who only *appears* to be you. The battle proceeds in the normal way (See Rules for Fighting), but only if the creature wins in that battle will the real you have to fight him.

11. Elusiveness: This makes you difficult for an enemy to hit. You will lose only 1 Strength point for the first three rounds of that battle (See Rules for Fighting).

12. Madness: An enemy's actions become completely wild and unpredictable.

13. Revitalization: Restores Strength points to their *Initial* level (See Rules for Fighting).

You choose six of the Potions. Each will work only *once*, but you may drink a potion at any time, except during a battle.

Wondering whether you have made the right choices, you walk back up to your room, and look round again.

Certainly you will need your sword, and some kind of armour. You pick up your sword and practise a few strokes. You feel confident. You will go to the town of Darkblood and find out whether the stories are true. Perhaps, you may even meet the Ruler – and challenge him!

You buckle on your sword and shield and a leather breastplate, and prepare to leave. Eleutheria's words come back to you as you close the door behind you: “. . . you must know how to decide which is the best course to take . . .”

For a moment, you hesitate; then resolute, you stride confidently along the corridor, down the stairs and out of the Academy. You take the road East, wondering briefly whether Eleutheria will use his Magic to transport you

back to the Academy. But nothing happens, and you continue East until you reach the town of Darkblood.

You walk through the gates into the town: there seems to be a tremendous party in progress. Creatures of all shapes and sizes are swilling ale, laughing, singing, fighting, and you stop in the main square to watch this spectacle.

A strange, misshapen creature sidles up to you. It is only about four feet high, and although its left leg and arm are green and warty, the toes and fingers webbed, the right half of its body is perfect. The creature can speak only with difficulty, the words slobbering from his mouth.

“Stranger,” he pleads, “we have not seen such a warrior before in Darkblood for more years than I can remember. You must take the two jewels from the Wizard Belenghast, and replace them where they rightly belong, in the Temple of Valadon. Then will his hold be released, and our town may once again return to its former state of peace and tranquility.”

As the creature speaks, a figure lurches towards you. It is cased in chain-mail, and wears a helmet. Suddenly, the strange figure swings a mace at you, but your four years of training have more than prepared you for such an attack.

You do not even draw your sword. Ducking under the wild swing with the mace, you strike a straight-fisted blow to the heart, and as the figure falls to its knees, a double-fisted blow behind the head.

The creature lies dead at your feet, and again the half-man, half-toad appears at your side.

“Come with me, Stranger,” he asks, and you feel yourself unable to refuse. You follow him to a dimly-lit but where sit a strange collection of creatures. One has the body of a snake, but the face of a man, another the body of a crawling insect.

“I am Golfreth,” announces your companion. “Once I was a shield-maker, but now I can no longer ply my trade. The same is true of the rest of us. We have tried to enter the Tower above, some of us *have* entered. Few have returned, and those that have are in the pitiful state you see. Until a warrior can be found who can reach Belenghast, and replace the

two jewels in the Temple of Valadon, our city will remain in chaos. Will you help us?"

You are excited and intrigued by the prospect, but you need more information. You learn that Belenghast is a great soldier who also knows something of magic, and that he lives in the tower beyond.

"You must climb to the second storey," intones the insect-man, "before you reach the residence of Belenghast. And without the Amulet of Stone, you will not succeed."

You press the pitiful creatures for further information, but there is little else they know. Once you enter the Tower, there are many traps and pitfalls. The route to Belenghast is protected by strange creatures, some very powerful, some cunning, and some skilled in

the use of Black Magic.

None has ever seen Belenghast, though he is rumoured to be able to change his appearance at will. Only the fabled Amulet of Stone, lost somewhere in the Tower, will reveal the true Belenghast.

You leave the hut as the sun rises, and look at the Tower ahead. It is a forbidding structure, and reminds you of a volcano. But you press on, determined, pushing your way through the crazed townsfolk, until you reach the foot of the Tower. A stone archway is ahead of you, and beyond that is darkness. You go back, push, your way into a Tavern, and take a torch from the wall. Lighting it, you walk back, through the archway, into the Tower of Terror.

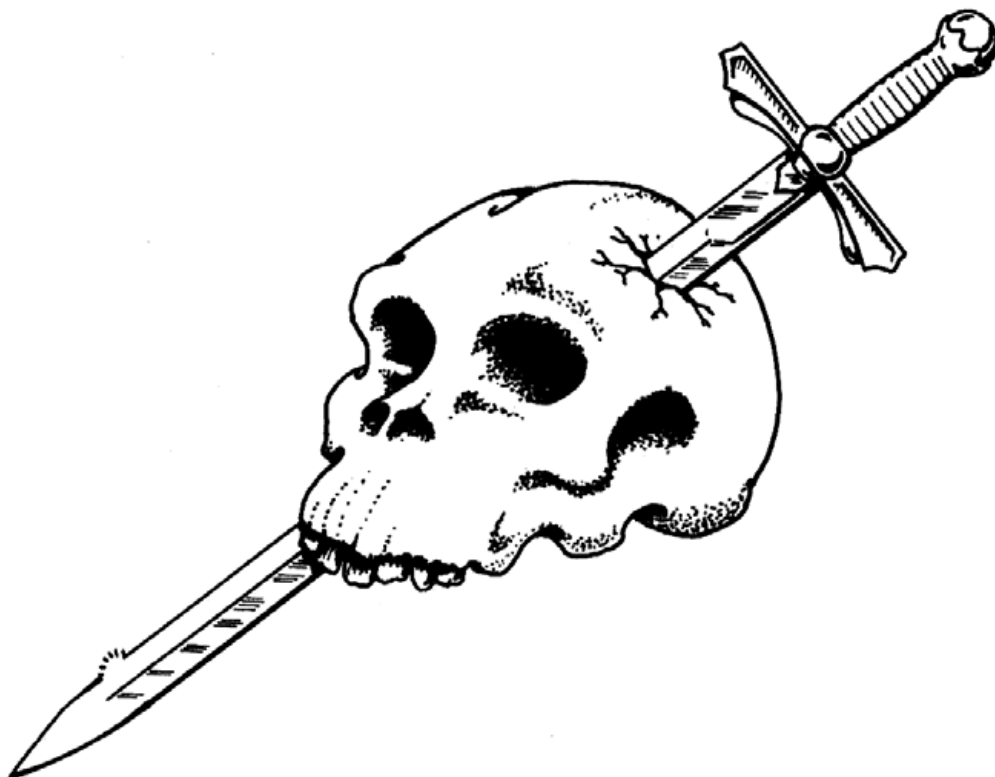

NOW TURN OVER

1

You are in a tunnel leading North. Your torch flickers, and you feel a chilly wind on your face. You seem to hear voices – “Return, Stranger,” says one. As you wheel round, there is a voice behind you: “Only death awaits you here:” You turn again, draw your sword and stand resolute. The voices recede, fading into the black rock on either side of you. It is suddenly eerily silent, but you press on Northwards. Turn to **162**.

2

You realise that the tunnel is sloping downwards. Worse, the floor is covered with some slimy substance, and you feel yourself starting to lose your footing. Roll two dice. If the score is less than your Dexterity score, turn to **27**. If it is the same or greater, turn to **81**.

3

The passage is quite wide, and you can see ahead fairly well. All is quiet; you pass a way leading South, but press on. Turn to **170**.

4

The passageway soon narrows, until you have to turn sideways to inch your way along. As you press on, your torch ahead of you, there is a sudden fearsome pain in your right leg. Wiping the sweat from your eyes, you can just make out that your leg is trapped in the jaws of a powerful metal *mantrap*.

In your restricted position, it is difficult to move easily, and you put down the torch so that you can take the jaws of the *mantrap* in both hands and force them apart.

With great relief, you limp over the horrible trap and pick up your torch again to look at your leg. You have lost some blood, but the wounds will heal. Lose 3 Strength points. Your training has taught you to overcome pain, and you move steadily forwards, until you reach a junction. Gain 1 Courage point. South, you can just make out a faint light from the entrance to the Tower, and so you continue West. Turn to **180**.

5

You walk Eastwards for a while, until your way is blocked by a door. It is a solid wooden door, covered in cobwebs, and does not look

very inviting; however, you push tentatively at it, and it opens. The light of your torch barely penetrates the thick, suffocating blackness inside, but you can just make out an archway in the wall opposite.

As you move towards it, you stumble on something on the floor. You recoil – it looks like a corpse that has been there for some time, the flesh rotting away from the bones and maggots crawling out of its mouth. As you instinctively move away, its eyes suddenly flick open, and it moves towards you. The door behind you slams shut. Lose 2 Courage points as you back away in terror.

You cut and slash at it with your sword, but it has no effect. The ZOMBIE is not vulnerable to ordinary weapons, and no Potion of Magic is any use against this creature. Do you have a silver lance? If so, turn to **29**. Otherwise, turn to **165**.



6

Going wearily East, you come to another junction. There is a way South, or you could continue East. As you consider, you hear a hollow grating sound behind you, and turn to see that a slab of rock has slid across and closed off the passage behind you. Will you now go:

- East? Turn to **31**
- South? Turn to **12**

7

The passage goes South, and then turns East. But shortly you reach a junction. Will you now go:

- North? Turn to **56**
- South? Turn to **37**



8

The silver key fits the lock and turns easily, and you push open the door. You are in a small stone room, and you quickly realise that even the sparse furnishings – the table, chair, and bed – are also of stone.

A snuffling, grunting sound from your left makes you wheel round, and you are face to face with a TROLL. The TROLL is a small, squat creature, smaller than you, but as broad across. He is bald, and has an ugly, fearsome face.

He moves towards you, wielding a short silver lance, which he suddenly thrusts at you. Roll 2 dice. If the score is less than, or equal to, your Courage score, turn to **101**. If it is greater, turn to **113**.

9

You tell him that you wish to reach the quarters of Belenghast, and ask him which way to go next. He looks at you sidelong, and says, “The safest way is to go East out of here, take the first passage North, and then go East.” But your intuition tells you that he is

lying, at least partly. You leave the room. You may now continue East – turn to **90** – or go back West – turn to **10**.

10

Going back, you quite soon pass an opening on your left. You can see daylight that way, from the entrance you originally came through. You are back at the junction. Will you now go:

West?	Turn to 196
North?	Turn to 167

11

The potion works almost at once, and you feel yourself floating into the air. A long way below you, you can see red-hot molten rock bubbling and spitting at the bottom of the chasm. But you float safely over, and land with relief on the other side. Thankfully, you press on quickly Northwards, and soon the passage turns East. You continue. Turn to **30**.



12

The passage goes South for some way, then East for a while, before turning South again. It is deathly quiet.

You arrive at a junction. Will you:

Continue South?	Turn to 41
Go back North?	turn to 72
Try the way West?	Turn to 183

13

You run, breathless, East, until you encounter a wall. You stop to recover your breath. You see that you are at a junction. Will you now go:

North?	Turn to 72
South?	Turn to 41

14

You overbalance, and fall into a pit. You are relieved at first, because you land on what feels like soft sand. But when you try to get out, you realise that something is dragging you down.

You are in a pit of quicksand, and the more you struggle, the more the quicksand sucks you under! You are soon almost up to your waist, and must act quickly.

You can just reach the rim of the pit with one hand, and begin hauling yourself out. It is an exhausting task, and takes all your training and concentration, as you slowly drag yourself nearer back to the rim. Then you can take hold of the rim with both hands, and, after an exhausting struggle, pull your whole body finally free. Lose 7 Strength points, and, if you are still alive, turn round and go back. Turn to **95**.

15

As you drink the potion, the GIANT lets out a deafening shriek, smashes his fist into the rock wall, then suddenly charges at you, roaring and screaming. You barely have time to realise that the Potion was not a wise choice before you are locked in battle with the enraged GIANT!

	<i>Dexterity</i>	<i>Strength</i>
GIANT	12	18

If you survive, turn to **126**.

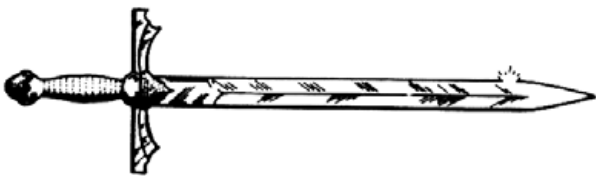

16

You move into a kind of alcove. It is extremely dark, your torch barely penetrates the blackness, and it smells damp and cold. You can just make out, on the wall opposite, some writing on a plaque. You are about to go over and read it when you notice a small wooden chest, bound in brass, on the floor. will you:

- Try to open the chest? Turn to **157**
- Go over to the wall to read the inscription on the plaque? Turn to **97**

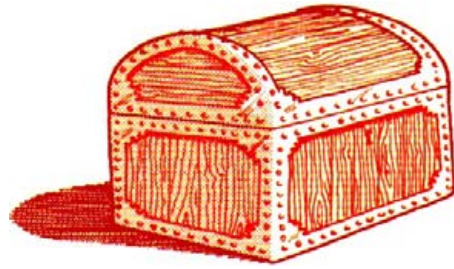

17

Your foot catches on a wire – and a hidden trap is sprung. The way behind you is closed off by a wall of rock, and a rumbling noise makes you look up. You realise that the ceiling of the tiny room you are trapped in is steadily descending. You push against it with all your might, but it continues its relentless descent, and you will finally be crushed like an insect, lost in the depths of the Tower of Terror.

18

The potion works – you are now very difficult to wound. You will lose only 1 Strength point, instead of 2, for the first three successful attacks against you. After that, the potion wears off, and each successful attack against you by the SCRAFE will cause the usual 2 points of damage.

	<i>Dexterity</i>	<i>Strength</i>
SCRAFE	10	12

If you win, turn to **152**.



19

You pull the levers. They do not move easily, and it takes all your power to drag them out, but you are rewarded by the sight of the door opening.

You go into a large room. Suddenly remembering the Wizard, you clutch the Amulet and turn. The Wizard is furious. He moves towards you, and as he does, so, his appearance changes.

He is no longer an old man with a stooping stature, but, as you watch, he grows tall, towering above you. You realise that this is BELENGHAST.

His robes have re-formed into the finest, gleaming, chain-mail, and he wields a fearsome double-headed axe as he advances towards you, spitting hate. You must quickly choose to try: a Potion of Magic, if you have one – turn to **40**, or else you must fight him unaided – turn to **141**.



20

You travel East for what seems like a long time. The passage narrows and becomes colder. You soon pass under a stone archway, and find yourself in a small, square room. As you begin to walk across, the floor suddenly tilts, and you are thrown against the wall. You stand up again, but now the floor is moving from side to side, as well as rocking and tilting like a ship in a storm. If you have a potion of Flying, and wish to use it here, turn to **160**. Otherwise turn to **121**.

21

You push at the door, gently at first, and then more determinedly, but it does not move in the slightest. You examine the rock door more carefully, and see that there is a bright silver keyhole set in it. If you have a silver key, turn to **8**. Otherwise, you will have to continue North. Turn to **193**.

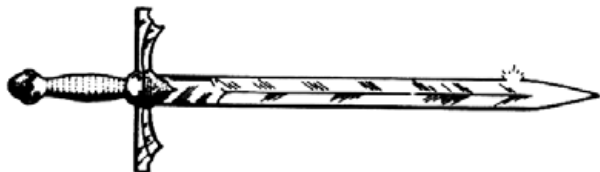

22

You open the door. It is pitch-black beyond, and you hold your torch high as you step warily forwards. You have taken only three steps before you step off, and plummet into a pit of boiling sulphur. Your dying screams echo in the blackness, but there is no-one to hear them. Your adventure ends here.

23

Ahead of you is a solid, brass-bound oak door. It looks very strong, but you notice a small, wedge-shaped slot on the left-hand side. Have you got an Amulet of Stone? If so, turn to **99**. If you have not, turn to **28**.

24

The door is stout, and firmly locked. Have you got a crystal key? If so, turn to **119**. Otherwise, you may try charging the door – turn to **158**; or else leave and continue East – turn to **86**.



25

You see that there is a figure in front of you. It is a wretched, filthy man, hung by his ankles by rope set in a hook in the wall.

The awful smell makes you want to back out again, but you notice something in front of his face – it is an Amulet of Stone, tied round his neck. Will you:

Snatch the Amulet, and
leave quickly?

Turn to **105**

Risk cutting him down?

Turn to **51**

Take a potion of truth-telling,
and then talk to him?

Turn to **155**

26

Your double suddenly appears, and moves in for combat. But BELENGHAST merely sneers, utters a few words, and then slices it in two with the great battleaxe.

“Your magic is too weak, Stranger,” he says. You close in final combat:

	<i>Dexterity</i>	<i>Strength</i>
BELENGHAST	14	22

If you defeat him, turn to **198**.



27

Struggling wildly, you manage to regain your footing, and clamber back to the main passageway. You lean against the wall with relief, and only now realise that your hands and arms are very painful. You pick up the torch, still alight on the ground, and can see that the skin is peeling from your hands and arms – the unpleasant stuff on the tunnel floor must have been acidic, and it will take time for you to heal fully. Lose 4 Strength points. If you are still alive, you take a deep breath, and go North again. Turn to **71**.

28

Without the Amulet, you can go no further. You may charge the door, strike it with your sword but it will not move. You have failed in your quest.

29

The ZOMBIE backs away, eyeing your silver lance warily. You close for the attack. Even though you have the lance, the ZOMBIE is a formidable enemy.

	<i>Dexterity</i>	<i>Strength</i>
ZOMBIE	11	20

After you have scored *three* blows with the lance, turn to **116**.

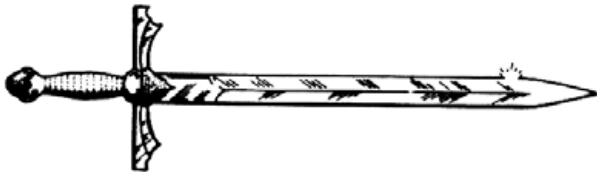

30

As you walk East, you hear a faint fluttering in the darkness ahead of you. You press on, your sword and shield at the ready, until you realise that dozens of flying creatures are swooping and diving around you. By the light from your torch, you see that each flying creature has the body of a huge bat, with razor-sharp talons, but the face of a Ghoul. You swing your sword, and most of them retreat into the darkness, but three continue the attack. Fight each in turn. If you have a potion of Invincibility, Elusiveness, or Power, you may use it here if you wish – but only against the *first* DEATHBAT.

	<i>Dexterity</i>	<i>Strength</i>
FIRST DEATHBAT	11	8
SECOND DEATHBAT	10	6
THIRD DEATHBAT	8	8

If you defeat all three, turn to **6**.



31

You continue for a short while, until you reach a passage going North. You decide to take it – turn to **42**.

32

The tunnel goes South, then after a while turns West. You have gone West only a short distance when your foot catches on something and you stumble. Roll two dice. If the score is less than your current Courage score, turn to **88**. If the score is the same or greater, turn to **14**.

33

The tunnel continues East for a while, and then turns sharply North. You follow this passage until you come to a junction. A new tunnel leads off East. Will you:

- Take the passage East? Turn to **147**
- Continue North? Turn to **159**

34

You put away your sword and tell him that you are seeking the way to the quarters of Belenghast. He looks scared, and tells you that it was Belenghast who ordered him to be locked up, for daring to question an order. "This is a dangerous place," he says, "but if you really wish to find Belenghast, go East from here, take the first passage North, and then East again." He looks shiftily around him, then suddenly runs past you, out of the door. Puzzled, you go back out through the shattered doorway yourself, and continue East. Turn to **90**.



35

The potion quickly takes effect, and you go East. Turn to **5**.

36

After a while, the passage turns South. Quite soon after that, you see a tunnel on your left. Will you now:

- Take the passage East? Turn to **147**
- Continue South? Turn to **61**

37

Continuing, you soon come to a new passage. Will you:

- Take this passage East? Turn to **20**
- Continue South? Turn to **65**

38

You go back, past the passage South, and continue West. Turn to **58**.

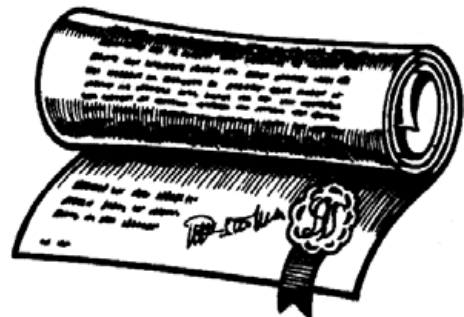

39

The passage narrows, and the air starts to feel cold and damp against your skin. You move on, and quite soon come to a crossroads. Will you now go:

- North? Turn to **167**
- South? Turn to **83**
- East? Turn to **62**

40

Will you try a Potion of:

- Fear? Turn to **154**
- Madness? Turn to **106**
- Duality? Turn to **26**

41

After a short while, the tunnel turns East. You keep going, but the tunnel stops after a short time at what seems to be a dead-end. You feel around the wall, looking for levers or secret passages. There is a click – you must have touched something. You hear a grating sound from behind, and turn to see a slab of solid rock slide across. You will end your days walled up in this tomb in the Tower of Terror.



42

You turn North, and after a short distance, your way is barred by a huge oak door. Have you a bronze key? If so, turn to **148**. If not, turn to **96**.

43

Back on firm ground, you continue East, but quite soon the passage turns North. You follow this for some way. Turn to **164**.

44

The passage continues North for a long way. After a while it becomes narrower, and begins sloping upwards, and it starts to become much hotter. You wipe the sweat out of your eyes and continue, but it feels as though the whole tunnel is shaking around you, while the heat increases. After a few seconds, you realise that this is no illusion – the ground and the walls are indeed trembling and shaking. The shaking suddenly becomes violent, and you are hurled against the wall of the tunnel. Lose 2 Strength points.

As the shaking continues, you can see that ahead of you, the ground has opened up – there is a huge chasm. The shaking continues; if you have a Potion of Flying, and wish to use it now, turn to **11**. Otherwise, you will have to run back South, and take the passage East. Turn to **5**.

45

The passage widens, and you soon realise that the rock itself is giving off a kind of light, a natural, phosphorescent green. You continue warily Northwards. After a short time, you see a new passage on your right. Will you:

Take this new passage East? Turn to **111**
Continue North? Turn to **156**

46

You swing your sword – and he is gone! You hear a voice behind you: “You are not swift enough, stranger.” You turn to see him standing behind you. You try again and again to land a blow, but every time you do, he melts away, only to reappear somewhere else. Lose 2 Dexterity points. Frustrated and angry, and with the laughter of the little man ringing in your ears, you push back through the splintered door and continue East. Turn to **90**.

47

The ZOMBIE’s arms reach for your neck as you run for the archway. They begin to close around your neck, but with a last, desperate effort, you wrench yourself away, and run through the archway, East. Lose 6 Strength points and, if you are still alive, turn to **13**.

48

You will lose only *one* Strength point for the first *three* times that the STONEMAN scores a blow on you in this battle. Thereafter, you will lose the usual 2 Strength points when the STONEMAN scores a blow against you.

	<i>Dexterity</i>	<i>Strength</i>
STONEMAN	12	14

If you defeat him, turn to **117**.

49

You continue East until you get to a junction. South is a cold, dark, narrow passage, and you decide to go North. Turn to **178**.

50

This time the door splinters open, but the effort still costs you one further Strength point. If you have any Strength left, you kick the shattered door away and go through. Turn to **25**.

51

You lean him against the wall, and he thanks you. He tells you that, like you, he was once an Adventurer, and that he got his name Swiftfoot because of his great agility and stamina.

He, too, had been in search of Belenghast, and had found the fabled Amulet of Stone, when he was ambushed by three FACELESS GUARDS, close to the quarters of Belenghast. The FACELESS GUARDS then decided to hang him like this, rather than kill him at once, so that he might die slowly. He does not know how many days and nights he has been there.

He tells you that the passage goes South, then East and then North again, before finally turning East. He gives you the Amulet and wishes you well. If you have any left, you give him one portion of your rations before leaving to continue East. Turn to **86**.

52

You walk under the arch. Ahead of you is an impenetrable blackness. If you would rather leave, and go back North, turn to **129**. If you wish to press on Westwards, turn to **17**.

53

You go West for what seems like a long time, until you finally arrive at a junction. Will you now go:

North?	Turn to 98
South?	Turn to 65

54

You have gone only a short distance before you come to another junction. The passage runs North-South. Will you:

Go North?	Turn to 127
Go South?	Turn to 73

55

You ask him which is the safest way to go. He seems to fall into a trance, and then tells you that the best way is to go East, and then North. You are convinced that he is lying, but thank him and leave. Will you now go:

East?	Turn to 90
West?	Turn to 10

56

You have been going North for a little while, when you suddenly cry out in pain. You twist your head to see a poison dart in your neck. Lose 3 Strength points. If you are still alive, you wrench it out and press on warily North. You come to a passage leading off to your left.

Will you:

Take this way West?	Turn to 79
Continue North?	Turn to 145

57

Walking South, the tunnel narrows, but then widens again. You move forwards, but suddenly, from above you, you hear the sound of rushing air. A fierce pain begins spreading from your shoulder, and you turn your head to see a poison dart in your neck. Lose 3 Strength points. You wrench it out and – if you are still alive – press on South.

There is a passage on your right. Will you now:

Take the new way West?	Turn to 131
Continue South?	Turn to 37

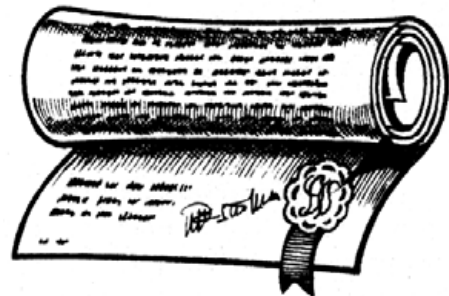
**58**

The passage turns North after a little while, and soon you see a new way off to the right. Will you take this new way East? Turn to **142**. Or continue North? Turn to **177**. If you have one, you may take a Potion of Searching instead, if you wish – turn to **103**.

59

You soon come to a junction. Will you go:

North?	Turn to 77
South?	Turn to 32

60

Three blows from your sword, and the door is splintered. You kick open the shattered door and look inside. Turn to **114**.

61

The way South turns West after a short time, and you get to another junction, with a passage running North-South. Will you:

- Go South? Turn to **197**
- Try the way North? Turn to **179**

62

You move warily down the passage, but all is silent apart from a faint echoing sound, as water drops from the roof of the tunnel.

Continuing East, you hear an odd noise from your right. Will you:

- Investigate? Turn to **151**
- Continue East? Turn to **90**

63

As the Potion begins working, the strange characters seem to dissolve before your eyes, and re-form. You read:

“Go North from here, and then go West –
 Release the man enchained in fear.
 Do not attack or harm him lest
 You take his place above you here.”

You memorise the words on the parchment. Will you now:

- Leave, and continue East? Turn to **54**
- Investigate the plaque? Turn to **97**

64

You try the door, and it swings easily open. You walk into a very small room. Your torch-light plays over the rock all around, but the room is completely empty. Disappointed, you leave, and go West. Turn to **59**.

65

After a short time, you see a passage to your left. Will you:

- Take this passage East? Turn to **186**
- Continue South? Turn to **32**

66

Continuing North, you find yourself at a junction. One way leads East, the other West, and both appear equally menacing. Which will

you choose?

- East? Turn to **169**
- West? Turn to **180**

67

You close the door behind you. You are in a narrow corridor going North, but it very quickly turns left. After a few paces, you see that it turns North again. There seems to be a way West, but the light is blinding as you approach. You turn your head away from the fierce fight and heat and go North instead. Turn to **144**.

68

You continue for some way, until you find that you cannot go any further. In front of you is a stone wall; the wall looks too smooth to be natural, and you search for hidden levers, but find none. Nothing you can do will move the wall, and you are about to return to the last junction, and go North, when you realise that there is a way South. If you wish to take this new way South, turn to **12**. If you would rather go back and head North, turn to **42**.

69

You take two steps back, raise your shield to your shoulder, and hurl yourself at the door. It splinters into fragments, and you stumble into a tiny room.

You look about you. The floor is stone-flagged, the walls are solid, it seems that you are in an empty room. But as you are about to leave, you become aware of a faint noise, like glass gently tinkling. There is nothing to be seen, but as you stand there, the sounds form into a faint, glittering voice inside your head.

“Go North, and then West,” the voice seems to say.

You shake your head, wondering at this, and leave the room, going North. Turn to **66**.

70

You walk warily along a short, well-lit corridor. You stop at an imposing door ahead of you: but when you push, it swings open, and you move through to find yourself in a spacious, airy room, furnished with ornate wall-hangings, and row upon row of books.

You go over and look at the books – they are all Books of Spells, or Instructions in Magick, and you are feeling pleased with this find when a movement of the air makes you turn around quickly. Sitting in a large, ornately carved chair is a fierce-looking old man, clad in long flowing robes. He has very long hair and a long beard. You draw your sword – he glares, utters a few words – and your sword turns to rubber in your hand!

“Put that away, Adventurer,” he commands, “it will return to normal, soon.” You do as he tells you, realising that you are facing a powerful Wizard. Could this be Belenghast?

“I know of your quest, Stranger,” says the Wizard, “but I am not the one you seek. However,” he smiles, “I *may* allow you to continue.”

From his flowing robes, he takes out a leather bag and shakes it. It makes a dull rattling sound.

“A small test of reasoning,” he explains. “If you are right, you will – perhaps – be fortunate. If you are wrong, less so.” He shakes the bag again.

“I have in this bag,” he tells you, “some black stones, and an equal number of white ones. Now, if you were to put your hand in and take some, you could not know in advance how many would be white, and how many black.

You can work out, I’m sure,” he continues, “what is the smallest number of stones you should take from the bag in order to be certain of getting two of the same colour. However, my question is this: the smallest number of stones you must take from the bag to be certain of getting two of the *same* colour is the same as the number you must take out to be certain of getting two of a *different* colour. How many stones are in the bag?”

You hesitate, and he continues: “Your Potions of Magic will not work in this room, so do not waste them. There are three doors behind me. They have on them the numbers 4, 6, and 8. When you have decided on the answer to my little puzzle, go out through the door with that number on it.”

Will you take the door marked:

- | | |
|----|--------------------|
| 4? | Turn to 100 |
| 6? | Turn to 80 |
| 8? | Turn to 67 |

71

After only a few paces, you see a tunnel on your right. It is narrow, and you will have to crawl on all fours if you wish to investigate it.

Will you:

Try this tunnel East?

Turn to **137**

Continue North?

Turn to **163**



72

You are in a tunnel that goes North for some time, then West for a while, then turns North again. There are no other passages, and the air is deathly quiet. Eventually, you arrive at another turning: on your left, is what looks like a stone wall barring the way, and so you go East, until you see a passage to the North. You try this new way North. Turn to **42**.

73

You go South for some way, but then the passage turns West. Very soon, you pass under a stone archway, and find yourself in a small, square room. You move across, but as you do, the floor suddenly tilts, throwing you against the wall. As you regain your footing, the floor begins moving from side to side, and you are thrown to the floor again. The whole room seems to be crashing about like a ship in a storm. If you have a Potion of Flying, and wish to use it here, turn to **184**. Otherwise turn to **125**.



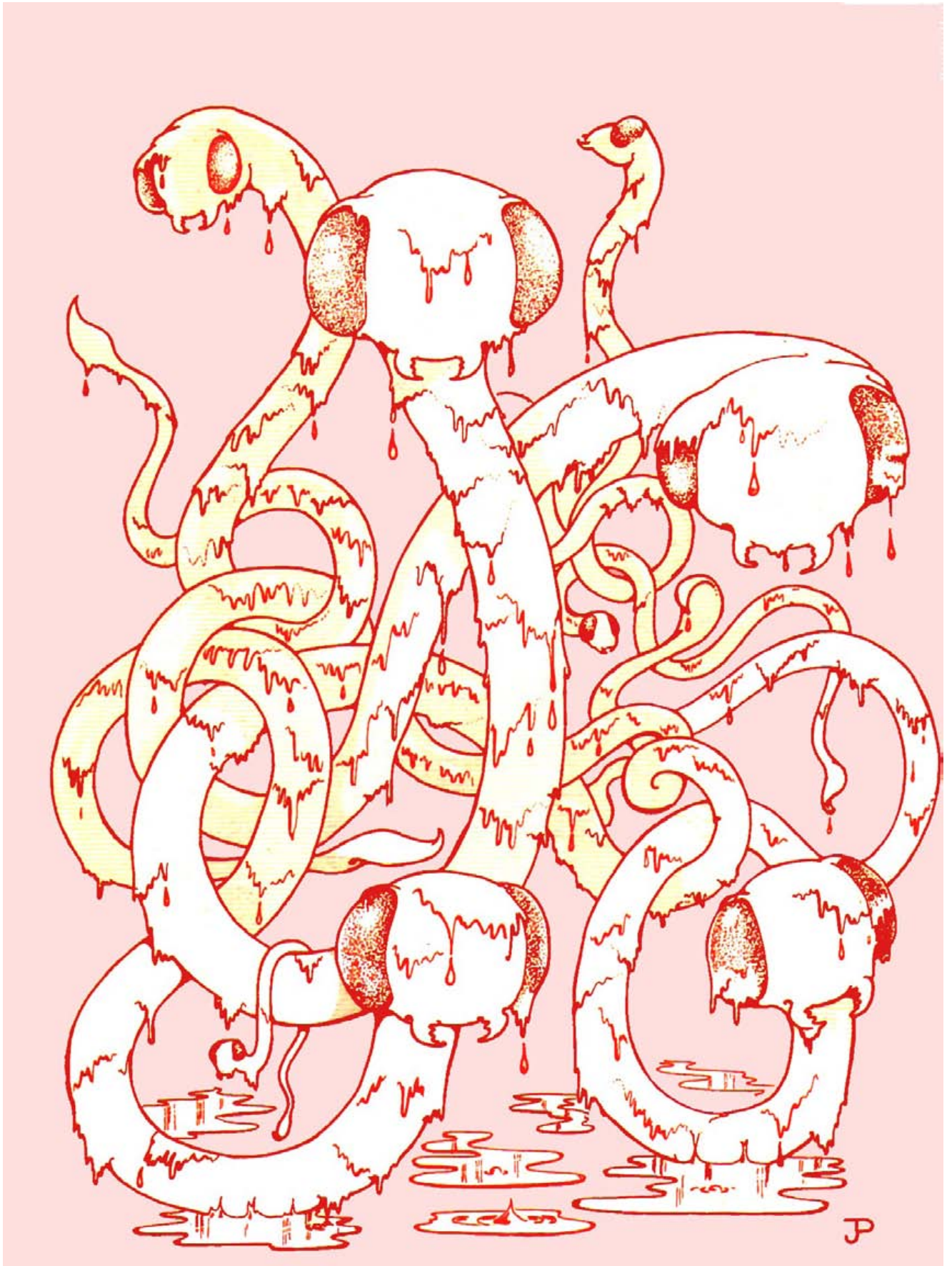

74

You are in a small, dark alcove, smelling of damp and decay. Your torch can hardly penetrate the deep blackness all around you. But you can see, on the wall opposite, some words inscribed on a plaque set in the wall. You also see a small wooden chest, bound in bronze, almost at your feet. Will you:

- Go over to the wall to read the inscription? Turn to **195**
- Try to open the chest? Turn to **94**

75

Quite soon, you reach a junction. The passage runs North-South, and you go North. Turn to **91**.

76

The short silver lance is a fine weapon, and you decide to take it with you. There is nothing else of interest, so you leave and continue North. Turn to **193**.

77

You go North for a short time, and then see that there is a new passage on your right. Will you now:

- Take the new passage East? Turn to **20**
- Go North? Turn to **98**

78

Going West, you see an opening on your left. Will you:

- Investigate? Turn to **74**
- Continue West? Turn to **89**

79

You go West, but quite soon the passage turns South. You go South for a short time, until you see a door on your left. Will you:

- Try the door? Turn to **192**
- Continue South? Turn to **7**

80

You close the door behind you. You are in a narrow corridor going North, but it very quickly turns right. After a few paces, you see

that it turns North again. There seems to be a way East, but there is a blinding light that way. You turn your face away and go North. Turn to **144**.

81

Try as you may, you cannot keep your footing, and you slide down the tunnel with increasing speed, until you finally roll to a stop on a bed of some spongy, slimy substance. You have lost your torch in your headlong fall, but you can now make out, by the dull-red glow from the rocks, that you are in a pit. You realise, with mounting horror, that what you have landed on is a nest of dozens of huge worms. Each is almost as long as you, and as thick as your thigh. They begin coiling round you, gripping as tight as snakes, and your leather armour dissolves. The slime that oozes from their bodies is acid, and is their way of digesting their prey. You swing your sword wildly, but to no avail – your adventure has ended here.

82

The door is as well-built as it looks, and only after repeated blows from your shoulder charges does it begin to splinter. Eventually, you are able to wrench it off its hinges, but it costs you 2 Strength points.

Beyond the door, there is a small, square room, and in the centre of the floor is a statue. You go closer, and see that the statue is of a large, broad-shouldered man with a low forehead and a menacing expression. But then you notice, at the foot of the statue, a crystal key. Carefully, you reach for the key, and as you do so, the statue begins moving!

You had half-expected this, and now leap back, your sword raised, as the STONEMAN moves towards you. If you have any of the following Potions, and wish to use them here, turn to the appropriate section:

- Duality Turn to **124**
- Elusiveness Turn to **48**
- Fear Turn to **102**

If you have none of these, or do not wish to use them here, you must fight the STONEMAN alone.

	<i>Dexterity</i>	<i>Strength</i>
STONEMAN	12	14

If you win, turn to **117**.

83

You have gone only a few paces before you realise that you are now heading back towards the entrance which you first came through.

Annoyed, you turn round and go back North. Turn to **1**.

84

You pull the lever, and feel a jarring blow that travels to your shoulder, knocking you to the ground. Lose 3 Strength points. If you are still alive, you get up and try the other lever – turn to **149**.

85

You feel tremendously powerful. For the first *two* rounds of this battle, each blow you score against the SCRAFE will cost it 4 Strength points. After that, each blow will cause 2 points of damage. Each successful attack by the SCRAFE against you will cost you the normal 2 points of damage.

Dexterity Strength

SCRAFE 10 12

If you win, turn to **152**.

86

The passage East turns South quite soon, and then goes Eastwards. You notice that the temperature is rising. You continue East, until the passage goes North. You follow the passage North for some while, and all the time the heat is getting worse.

Soon the sweat is running into your eyes, and you are beginning to feel exhausted. A strange buzzing noise becomes louder as you continue, until something flies into your face – it is a fly. You wave it away irritably, but within seconds there are hundreds of them, each nearly half an inch long, flying into your ears and nose and mouth! Despite the heat and your exhaustion, you run desperately North, until you are free of the horrible things.

As you continue, you are relieved that the temperature seems to be dropping again, and continues to do so until it is quite pleasantly cool.

You see a passage on your left, but ignore it. Turn to **178**.

87

You see that there is a keyhole set in the door, and try the key, but it does not fit. Turn to **109**.

88

You keep your balance, but one foot is caught by something. You see that you nearly overbalanced into a huge pit of quicksand, and that this is what is now dragging at your foot. You sit down, press the other foot against the rim of the pit, take your leg in both hands and heave. Lose 2 Strength points.

After a few seconds, your leg comes free of the treacherous quicksand, and you pick up your torch with relief, and go back.

Turn to **95**.

89

You go West, but quite soon the passage turns North. After a short time it turns West again, and then takes a sudden turning South. You go South for a short distance, until you see a new way on your right. Will you now:

Take the new passage West? Turn to **79**
Continue South? Turn to **57**

90

You cannot see very far ahead by the light of your torch, and have to move along the passageway using your hands against the walls to guide you. Your left hand suddenly encounters nothing at all, and you fall heavily, cutting your head. Lose 1 Strength point. By the light of your torch you can make out a new way North. Will you now:

Continue East? Turn to **120**
Try the way North? Turn to **45**

91

You continue North, your sword at the ready, but all is silent. You notice a tunnel on your left. Will you:

Try the tunnel West? Turn to **2**
Continue North? Turn to **71**

92

You fight the SCRAFE.

Dexterity Strength

SCRAFE 10 12

If you win, turn to **152**.

93

The door splinters and shatters, but you are shaken – it was tougher than you thought. Lose 3 Strength points, and turn to **114**.

94

The chest opens easily. Inside is a single piece of old parchment. It is so old that it looks as though it would crumble to dust if you were to touch it, but by the light of your torch, you can just make out the words written on it. You read:

“Bi Netherig evelin Oen,
Orovath y Han to ther,
Metheniken, baragrathen, ü
ty vathen elen pir.”

If you have a potion of Intuition, and wish to use it now, you may do so – turn to **108**. Otherwise, you may either go over to the wall to read the inscription on the plaque – turn to **195** – or you may leave and continue West: Turn to **89**.

95

You go East, and then North, until you come to a passage off to your right. Will you now:

Continue North?

Turn to 77

Take the way East?

Turn to 186

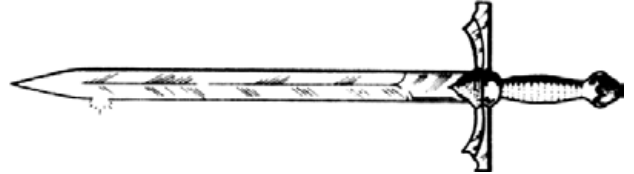

96

Do you possess a silver key? If so, turn to **87**. Otherwise turn to **109**.

97

As you move over to the wall, you trigger a trap. The alcove suddenly fills with dense, choking black fumes, and you stagger back out into the passage, gasping for air. Lose 3 Strength points. If you are still alive, you stop to regain your breath, and you go East again. Turn to **54**.



98

After going North only a short time, you see a new passage to your left. Will you:

- Continue North? Turn to **56**
- Try the passage West? Turn to **131**

99

You take the Amulet, and, using it as a key, fit it into the slot. There is a sound as of bolts being withdrawn, and then the door slowly begins to swing open.

You keep hold of the Amulet, move through the doorway, and look around you. Turn to **176**.

100

You are in a narrow tunnel. It goes steadily upwards, heading North, and then turns West. You realise that the roof of the tunnel is getting lower, and you are still climbing.

The tunnel suddenly turns North again, still going upwards, and you are relieved when the roof becomes higher again and you can stand properly. You climb up, and after a few minutes the floor levels off. You pass through a narrow archway, and find yourself in a wide passage, going North. Turn to **139**.

101

You leap aside, dodging the lance-thrust, and close in battle:

	<i>Dexterity</i>	<i>Strength</i>
TROLL	10	10

If you win, turn to **76**.

102

The STONEMAN cowers away, before returning to battle. But he is much less fearsome now. You fight:

	<i>Dexterity</i>	<i>Strength</i>
STONEMAN	9	14

If you defeat him, turn to **117**.

103

The Potion takes effect, and you turn East. Turn to **142**.

104

You go North, along a short passage, and into a fairly large cavern. There is the sound of

movement, and you see a bony, four-legged creature, with a long tongue and fierce-looking claws, stalking you. You may use a Potion of Magic here, if you wish to, and you have one – turn to **189**.

Otherwise, turn to **92**.

105

Holding your breath, you reach forwards and snatch the Amulet. You dash out of the filthy cell, and run East – but you are not looking! You trip and fall, and the Amulet shatters into a hundred pieces on the floor in front of you.

Disconsolate, there is nothing to do but continue East without it – turn to **86**.

106

Slightly to your surprise, the Potion seems to be working! BELENGHAST roars, smashing wildly with his axe; he seems blinded, and you quickly close in battle. You get in three good blows with your sword, but his armour is good, and he is only slightly wounded.

The Potion begins to wear off, and he becomes calmer. He turns to you with murder in his eyes, the great axe whistling over his head. You have weakened him, but now you must fight to the death:

	<i>Dexterity</i>	<i>Strength</i>
BELENGHAST	11	17

If you defeat him, turn to **198**.



107

As you pull the levers, there is a sudden, terrible flash of pain. You drop to the ground. Roll *one* dice: the score is the number of Strength points you have lost. If you are still alive, you may try again. Will you try:

- The left and middle levers? Turn to **19**
- The left and right levers? Turn to **140**

108

The potion begins working, and the strange words change and re-form before you; you read:

“Return, go North, and then go West
Release the man enchained in fear.
Do not attack or harm him lest
You take his place above you here.”

Will you now:

Return: Turn to **54**

Continue West? Turn to **89**

Look at the plaque set into
the wall? Turn to **195**

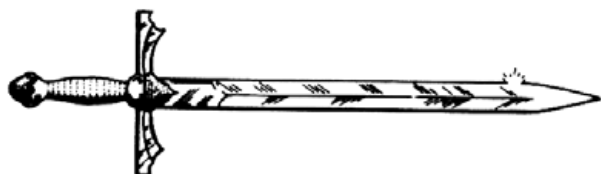

109

If you have a copper key, turn to **130**.
Otherwise, turn to **188**.

110

You go back West and take the passage
North. Turn to **45**.

111

The tunnel narrows, and you notice that it
seems to be getting colder. Quite soon, it turns
right, and it seems as though you are at a
dead-end. You are about to turn back when an
ominous rumbling warns you of danger. But it
is too late to do anything – the ground is
opening beneath your feet. Do you possess a
Potion of Flying? If so, turn to **112**. Otherwise,
turn to **128**.

112

Swiftly, you swallow the potion, and only
just in time! As you float in the air, you can
see, dimly, at the bottom of the great pit
beneath you, row upon row of closely-spaced
sharpened stakes.

You float gently backwards until your feet
are on firm ground again.

Wiping the sweat from your forehead, you
go back West to the junction and head North.
Turn to **156**.

113

You do not move quickly enough, and the
lance gashes your side. Lose 2 Strength
points. The TROLL looks strong, and cunning,
and he is quick with his lance. He makes
another sudden lunge, and you parry it with
your shield just in time.

You fight the TROLL.

	<i>Dexterity</i>	<i>Strength</i>
TROLL	10	10

If you defeat him, turn to **76**.

114

In front of you is a very small odd-looking
man, who seems to be kneeling on a tattered
rug. The room is completely bare as you look
round: there are no windows, there is no
furniture. The man stops wailing and looks at
you.

“Oh stranger,” he cries, “I have waited so
long for deliverance!” But something makes
you suspicious, and you raise your sword. He
cowers back. Will you:

Attack him?	Turn to 46
Try to talk to him?	Turn to 34
Use a Potion?	Turn to 168

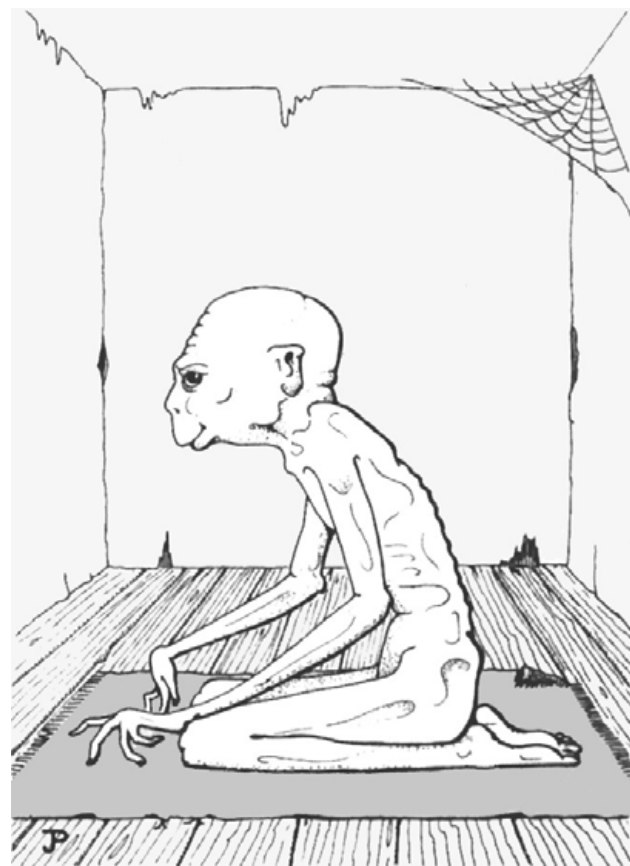

115

You continue East, but soon the passage turns sharply North. After a short time, you see a new way to your left. Will you now:

Take the new passage West? Turn to **78**
Continue North? Turn to **127**

116

As you drive in the lance for the third time, the maniacal yellow eyes dim, and the ZOMBIE falls suddenly to the ground.

As you watch, it crumbles away into dust, and from nowhere, a fierce cold wind suddenly swirls round the room, howling and shrieking. Just as suddenly, it fades away, and you see on the ground a key, glinting in the torchlight. It is made of bronze, and you quickly pick it up and pocket it before hurrying out through the archway. Turn to **13**.

117

You pick up the crystal key and put it in your backpack before leaving the room, and going West. Turn to **38**.

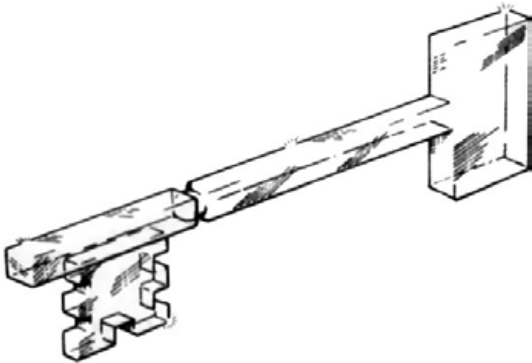
**118**

The potion takes effect immediately and the SCRAFE closes in combat with your double. Throw for each of them: your double has your current Dexterity and Strength scores. Only if the SCRAFE defeats your double will you have to fight it: in that case, your Dexterity and Strength scores will be at the level they were before this battle.

	<i>Dexterity</i>	<i>Strength</i>
SCRAFE	10	12

If you win, turn to **152**.

119

The key fits in the lock and turns. You open the door and go through – turn to **25**.

120

You walk along the passage for some minutes without incident, until you find that your way onwards is barred. The tunnel appears to be a dead-end. Standing back, you can see by the light of your torch that what bars your way is in fact a large boulder. You can make out a space between the top of the boulder and the tunnel roof, and you try at first to climb over. But the boulder is smooth, and you cannot get a hand-hold. After several failed attempts, you realise you will have to try something else. Have you got a Potion of Flying? If so, turn to **133**. Otherwise, turn to **138**.

121

You fight your way across the rocking, sliding floor, ignoring the pain as you are dashed repeatedly against the walls. Lose 4 Strength points.

If you are still alive, you grit your teeth and finally get to the other side. Turn to **115**.

122

You find no secret passages, but you kick something over as you search. You look down to see that it was a small casket, made of stone, out of which has fallen a copper key. You put this in your pocket, clamber back out of the tunnel, and continue North. Turn to **163**.

123

It is eerily silent as you head South. You can see nothing, but you have the feeling that invisible watchers are all around you. However, nothing happens, and you come to a junction. Will you now go:

East? Turn to **39**
West? Turn to **166**

124

The STONEMAN closes with your look-alike. Throw for each of them: your look-alike has your current Strength and Dexterity scores. Only if the STONEMAN defeats your look-alike will you then have to finish him off, with your Strength and Dexterity scores as they were before this battle.

	<i>Dexterity</i>	<i>Strength</i>
STONEMAN	12	14

If you (or your look-alike) win, turn to **117**.

125

You drag yourself across the rocking, shifting floor, but you are hurled repeatedly into the walls. Lose 4 Strength points.

If you are still alive, you manage to drag yourself across to the other side. Turn to **53**.

126

At the dead GIANT's waist, you see a small leather pouch. Inside is a silver key. Feeling that this may be of use to you, you put it in your pocket and continue North. Shortly, you realise you are at a junction, and may either continue North, or take a new passage that leads off to your right. Will you:

Take the new passage East?

Turn to **3**

Continue North?

Turn to **182**

127

You go North for a short time, but then the passage turns West. You follow the passage West for a long time, until it eventually turns North. You pass under another stone archway, and continue North.

Turn to **70**.

128

Without magic you are lost! Your screams echo for a long time in the cold and dark, as you fall headlong, to be finally impaled on the rows of sharpened stakes at the bottom of the Pit of Death.

Your quest is over.

129

The tunnel slopes upwards as you continue; as the slope becomes steeper, you are dragging yourself up on hands and knees. Lose 3 Strength points. Eventually you reach a shelf, and stop to get your breath. But you realise, as you look around, that this is a dead-end, and you will have to go back.

You clamber back South, ignoring the archway on your right, until the tunnel turns West, and you continue until you come to a junction. The passage goes North-South. Will you now:

Go North?

Turn to **159**

Go South?

Turn to **61**

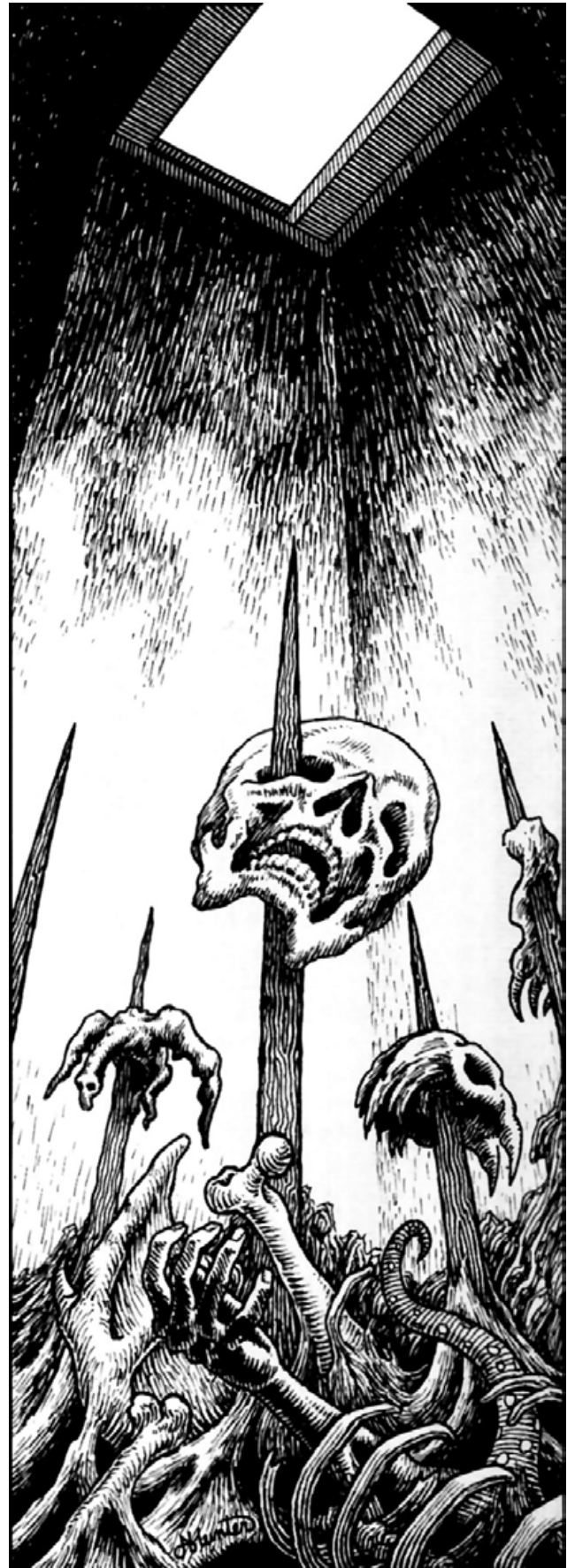

130

You try the key in the keyhole set in the door, but it does not fit the lock. Turn to **188**.

131

The passage goes West for a short time, then turns North. You walk North only a short distance before you see a door on your right.

Will you:

- | | |
|-----------------|--------------------|
| Try the door? | Turn to 190 |
| Continue North? | Turn to 173 |

132

The door opens easily, but the room beyond is completely empty. You explore the bare rock walls and floor by the light from your torch, but there is nothing to be found. Disappointed, you go back out and continue East. Turn to **36**.

133

You drink the Potion, and you rise magically into the air, floating over the boulder. There is very little room between the top of the rock and the tunnel roof, but you get through and land, light-footed, on the other side. Turn to **43**.

134

The eerie light from the rocks, together with your torch, allows you to see quite well, and ahead you can see that the passage bears North. You continue for some little way, watching and listening carefully, but all is deathly silent. You turn North, still taking great care, until you see that a passage runs off to your right. Will you:

- | | |
|------------------------|--------------------|
| Take the passage East? | Turn to 75 |
| Continue North? | Turn to 146 |

135

You walk back fifteen paces, put up your shield, and charge the boulder with tremendous force. You have learnt to smash through rock walls in your training, and expect the rock to shatter, but it seems to repel you as you hit it, and you land heavily on your back. Lose 5 Strength points. The boulder is completely unmarked, and you realise that you will have to walk back to the last junction and go North instead. Turn to **110**.

136

You now feel immensely strong. But the little man does not actually look very dangerous. Will you now:

- | | |
|-------------------------------|-------------------|
| Attack him? | Turn to 46 |
| Try talking to him after all? | Turn to 34 |

137

You clamber awkwardly into the narrow tunnel, your sword in one hand and the torch in the other, and move warily onwards, only to find, quite soon, what seems to be a dead-end. Will you now:

- | | |
|--------------------------------|--------------------|
| Search for hidden passages? | Turn to 122 |
| Get out quickly, and go North? | Turn to 163 |

138

Will you:

- | | |
|--|--------------------|
| Try your sword against the boulder? | Turn to 153 |
| Charge it? | Turn to 135 |
| Go back to the junction, and head North instead? | Turn to 110 |

139

You have gone only a short distance North when you come to a junction. Will you go:

- | | |
|-------|--------------------|
| East? | Turn to 174 |
| West? | Turn to 58 |

140

There is a flash of blinding bright pain as you pull the levers, and you drop, half-conscious, to the ground. Roll *one* dice: the score is the number of Strength points you have lost. If you are still alive, you may try again. Will you now try:

- | | |
|------------------------------|--------------------|
| The left and middle levers? | Turn to 19 |
| The middle and right levers? | Turn to 107 |

141

This will be a bitter and bloody battle to the death:

	<i>Dexterity</i>	<i>Strength</i>
BELENGHAST	14	22

If you defeat Belenghast, turn to **198**.

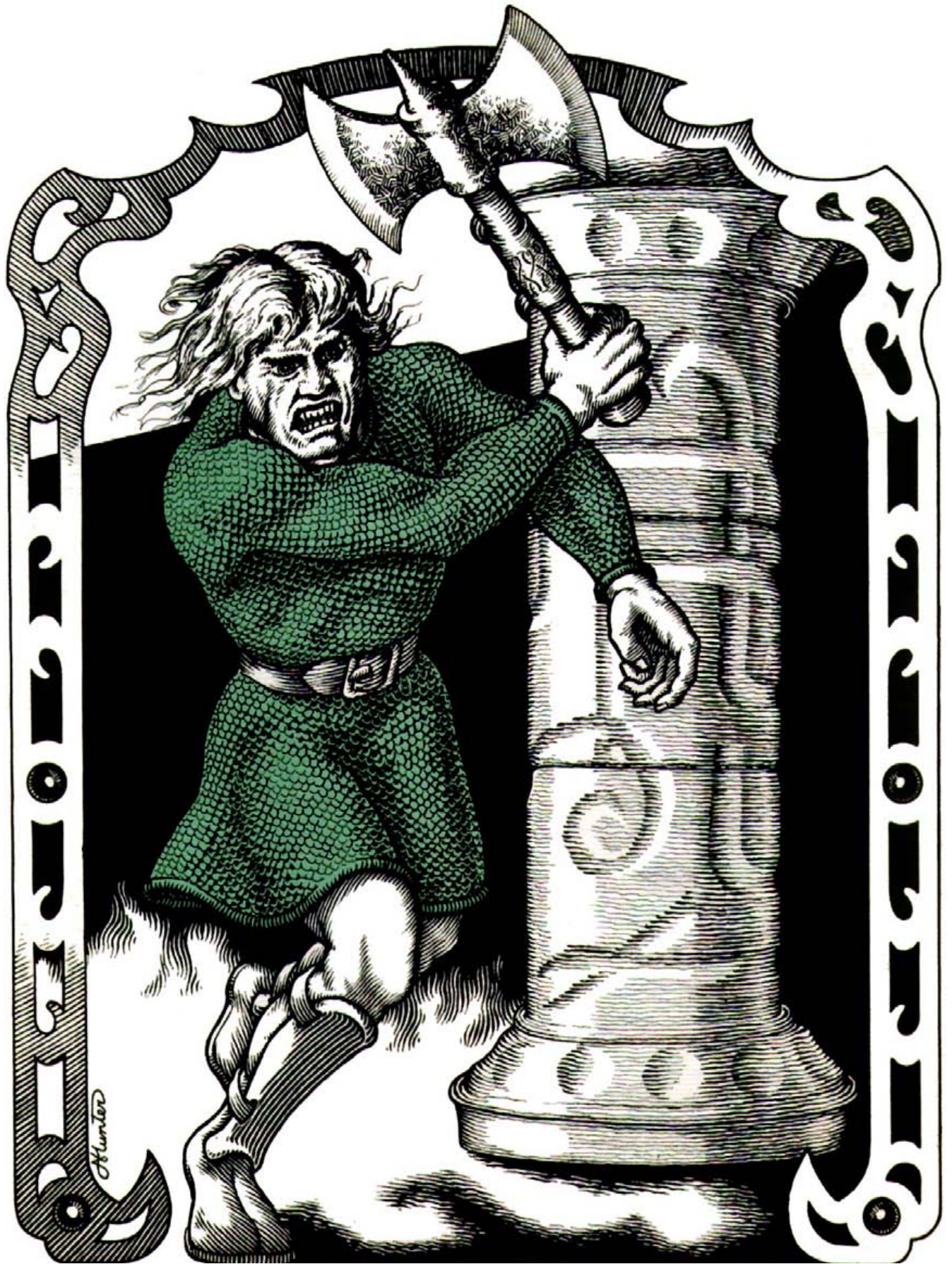



142

Going East, you come to a door set in the wall on your left. There are faint moaning noises coming from behind it. Will you:

Investigate?

Turn to 24

Continue East?

Turn to 86

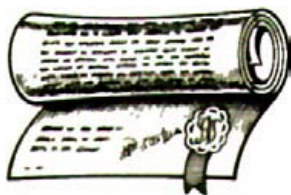

143

You go through the door. You are in a tunnel facing North, but it at once turns East, and, after a short time, goes South. You continue South, but the passage now turns East again, and you follow it until you reach a dead-end.

Looking closer, you can see that what is in front of you is actually a slab or rock. There are two levers set in the wall, and it looks as though one of them might open the rock-slab. Will you try:

The left-hand lever?

Turn to 84

The right-hand lever?

Turn to 149

144

You very soon turn East, and, after a short time, North again. You walk along a well-lit corridor, under an arch and into a small, circular arena, the floor covered with sand.

You draw your sword, and as you do, the fast of a dozen FACELESS WARRIORS enters from under the arch behind you. You have time to realise that you got the answer to the wizard's question wrong, as the FACELESS WARRIORS surround you.

Each is immensely strong and fast. They are the size of Giants, but more dextrous. Their name derives from the fact that they are entirely featureless: they have no eyes, no mouth, no ears. As the first FACELESS WARRIOR closes for the kill, his mighty sword buzzing past your ear, the others move in. You will die bravely against Belenghast's elite troops, but your adventure ends here.

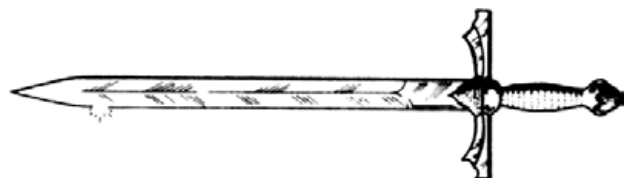

145

The passage goes North, then almost immediately, East. You go East for some time, until it turns South. Shortly it turns East again, and you go East until you see an opening on your right. It is dark beyond, and you can make out nothing by the light from your torch. Will you:

- Investigate further? Turn to **16**
- Ignore it and continue East? Turn to **54**

146

Very soon, the natural light from the rocks dies away, and you go forward more slowly. You feel a chilly wind on your face, and as you press on, the wind becomes stronger and colder, until it is howling about your ears, and you have to bend into it to make any progress. Your torch is extinguished like a candle, and you are fumbling forwards in total blackness, your hands outstretched.

Another hand takes yours: but it is ice-cold. You try to release your grip but cannot. You cut and slash into the darkness, but make no contact with anything, and you are dragged into the eternal cold darkness by the invisible Hand of Death.

You have failed in your quest.



147

You go East for a short distance, but then the tunnel turns North. You continue North for some time, until you notice an archway on your left. Will you:

- Try the way West? Turn to **52**
- Continue North? Turn to **129**

148

You see that there is a keyhole set in the door, and try the key. It turns, and the door opens. You open the door, move through, and close it behind you. Turn to **150**.



149

You are pleased – the lever pulls easily, and the rock slab slides back. You go through, and it at once slides into place again behind you. You now have a choice of two ways to go. Will you go:

- East? Turn to **49**
- North? Turn to **104**



150

You are in a tunnel leading North. You notice that the rocks give off a natural yellowish glow, which enables you to see quite well. You go North, and after a short time, see an opening to your right. Will you now:

- Take the new passage East? Turn to **33**
- Continue North? Turn to **179**

151

The light from the torch flickers and wavers, but you can make out a wooden door set in the rock. The odd noise is now a definite wailing sound. Will you:

- Step back, and charge the door? Turn to **93**
- Move away, and continue East? Turn to **90**
- Use your sword against the door? Turn to **60**

152

You look all around, but it seems your battle has been of little help to you – there is nothing to be found.

You go back South and go East again: turn to **49**.

153

There is an echoing *clang* as your sword strikes the rock. But it just bounces straight back off the smooth surface, leaving not even a mark on it. But you see that this has blunted the edge of your sword. Lose 3 Dexterity points. You will have to return to the last junction, and go North instead. Turn to **110**.

154

He laughs. he is completely unaffected. “Your magic is too weak against such a powerful Wizard as I am,” he bellows. You parry a sudden blow from the mighty axe with your shield, but are knocked backwards. You realise that he is enormously strong. Now it is a fight to the death:

	<i>Dexterity</i>	<i>Strength</i>
BELENGHAST	14	22

If you defeat him, turn to **198**.



155

You take the Potion, then ask him his name. He gasps that it is Swiftfoot, and you realise at once that he is telling the truth, and cut him down. Turn to **51**.

156

Going North, you shortly arrive at a junction. Will you now go:

East?	Turn to 134
West?	Turn to 4

157

The chest is not locked, and opens easily. Inside is a piece of parchment, and you read:

“Bi netherig evelin Oen,
Orovath y Han to ther,
Metheniken,baragrathen, ü
ty vathen elen pir.”

If you have a Potion of Intuition, and wish to use it now, you may do so. Turn to **63**. Otherwise, you may either go over to the wall to read the inscription on the plaque – turn to **97** – or you may leave and continue East – turn to **54**.

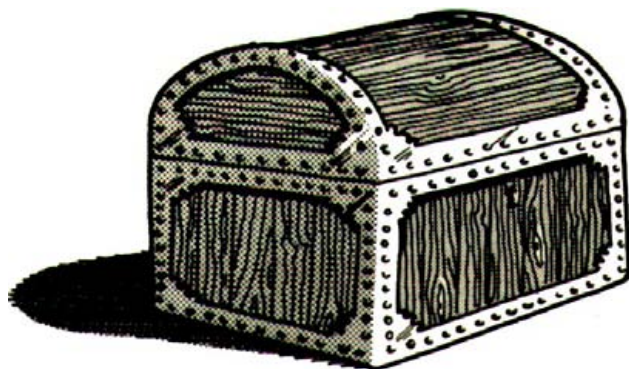

158

You charge the door – it cracks, but does not give completely. Lose 2 Strength points. If you are still alive, will you now:

Charge it again?	Turn to 50
Leave, and continue East?	Turn to 86

159

You continue North, and quite soon the passage turns West. You go this way, until you notice a door on your right. Will you:

Investigate?	Turn to 64
Continue West?	Turn to 59

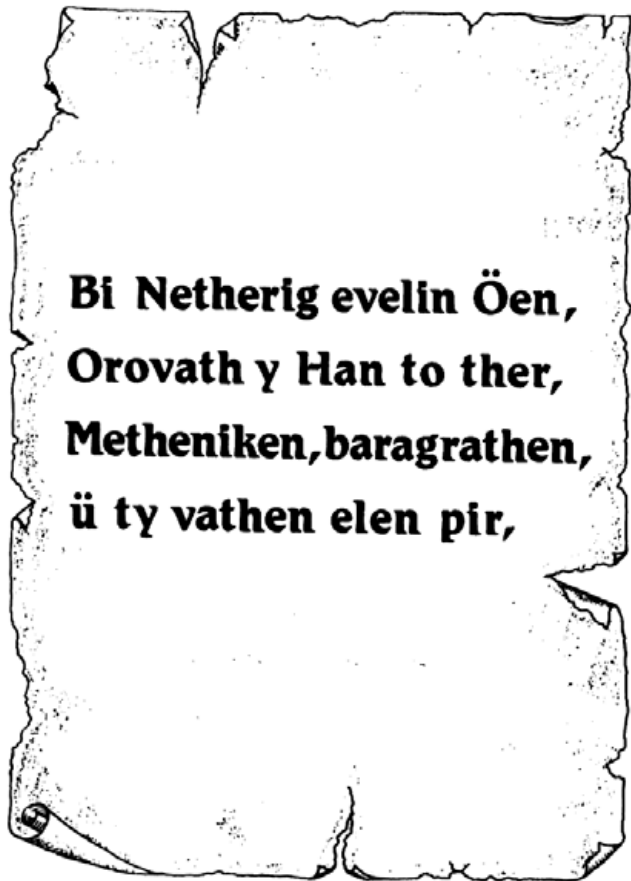

160

You suddenly float away from the rocking tilting floor, and land safely on the other side
Turn to 115.

161

After going South for some time, the passage turns West. You follow the passage, and see by the light of your torch a new way South; however, you decide that going South will just take you back to the entrance, and so you continue West. Turn to 4.

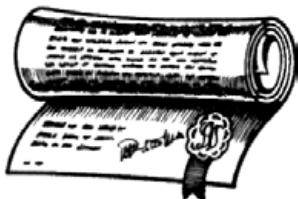

162

You reach a crossroads. Will you now go:
East? Turn to 62
West? Turn to 196
North? Turn to 167

163

After a short time, the passage turns to the West. You follow this passage for some way, until you see a passage on your right. Will you:

Take the passage North? Turn to 42
Continue West? Turn to 68



164

As you walk along the passage, your torch casts strange shadows all around you. Again, you hear voices, evil, high-pitched and cackling. You stop, but can see nothing. The terrible shrieking of the voices gets louder and louder, until you have to cover your ears against the screams and laughter. Finally, the frightening chorus begins to lessen, until at last it fades, echoing, into the rock.

Shaken, but still determined, you press on, until you reach a new passage going West. Will you:

Try the new passage West? Turn to 187
Continue North? Turn to 91



165

You run for the archway as the ZOMBIE lurches towards you. Roll 2 dice. If the score is less than your current Courage score, turn to 47. If it is the same or greater, turn to 171.

166

The passage continues West for a short time, and then turns North. From the darkness ahead of you, you can hear the sound of heavy footsteps, and you stop, your sword at the ready.

Soon, into the flickering light, lumbers the most enormous creature you have ever seen. Man-like, twelve feet tall, and dressed in skins, he carries a huge bone in his hand. Seeing you, he stops, growls, and raises the bone. You will have to fight the GIANT, but you may use magic to help if you wish. If you have any of these potions, you may take one now:

- Power Turn to 172
- Transparency Turn to 191
- Madness Turn to 15

Otherwise, you will have to fight the GIANT unaided.

	<i>Dexterity</i>	<i>Strength</i>
GIANT	12	12
If you defeat him, turn to 126.		



167

As you press on, it seems that the air is becoming colder. Above, below, and on either side of you there is only hard, black rock, and still the faint echoes of dripping water. But then you see, on your left, a door.

You move cautiously towards it, listening, but there is only silence from the other side.

Will you:

- Charge the door? Turn to 69
- Try to open it? Turn to 185
- Continue North? Turn to 66

168

- Will you drink a potion of:
- Intuition?
- Truth-seeking?
- Invincibility?

- Turn to 9
- Turn to 55
- Turn to 136



169

You have gone some way, and all is quiet. But then the passage starts to narrow, and you have to make your way sideways, holding your torch ahead of you. A sudden fierce pain in your leg stops you in your tracks, and you see by the light of your torch that your leg is caught in the jaws of powerful metal *mantrap*.

Dropping the torch, you force the jaws apart. Lose 3 Strength points but gain 1 Courage point.

Ignoring the pain, you pick up your torch and continue East, aware that you must be dripping blood. There is a passage South, but it seems dark and ominous, and so you continue on your way. You realise that the rocks themselves are giving a shadowy, greenish light, which allows you to see better ahead. Turn to 134.

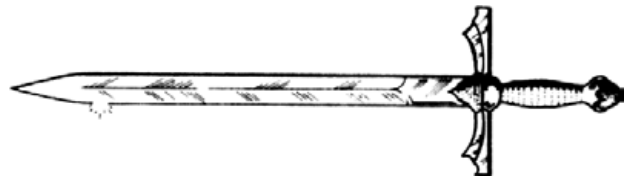

170

You follow the passage East for some way. Soon you come to a way leading South, and can just make out daylight in the distance from the entrance you originally came through. You continue East. Turn to 169.



171

You are not quick enough. Fear makes your feet leaden; the ZOMBIE's hands close around your neck, and your last memory is of its terrible face coming closer to yours, and its graveyard breath. Your adventure ends here.

A short way along, your passage is barred by a door. It looks sturdy, and there are no keyholes. You try it, but it is firmly locked. Will you:

Try to smash it down?

Turn to **82**

Leave, and go back West?

Turn to **38**



172

The potion takes effect: you feel immensely strong, and for the first *two* rounds of combat, each blow you land will cause *four* Strength points of damage to the GIANT. After that, each blow will cause only 2 Strength points of damage, as normal. Each blow to you will cost you 2 Strength points throughout the battle.

Dexterity *Strength*

GIANT

12

12

If you win, turn to **126**.

175

You go West. The passage becomes wider and higher, and you press on quickly. Turn to **194**.



173

The passage turns East, and ends at a junction. The passage runs North-South; will you go:

North?

Turn to **145**

South?

Turn to **57**

176

You are in a corridor, still facing East. You move cautiously along it, until you get to a similar door. There is no slot for a key, but there are some levers on the wall to your right.

As you look at them, wondering which to try, you feel the air move at your side. The Wizard reappears. "Congratulations," he says, "on coming so far. I will tell you this – you must pull not one, nor three, but *two* levers, in order to open this door." Will you choose:

The left and middle levers?

Turn to **19**

The middle and right levers?

Turn to **107**

The left and right levers?

Turn to **140**

174



177

The passage goes North for a time, but then turns East. You continue East, watching for traps, but all is quiet, and soon the passage turns North again.

The passage ends at a door, and as you consider what approach to take now, the door swings open on its own. You go through, and at once the door closes behind you. Ahead of you there are two more doors, one on the left-hand side of the wall opposite, and one on the right. Between the doors, and above them, a piece of parchment bears the words: **“One door is death, the other, life.”**

As you watch, two SPRITES appear. The SPRITES look at you – they are elfin creatures, but you are wary. You have heard stories of their dangerous tricks, and you know that when they appear in pairs, one of them always Ges, and the other tells the truth. But there is no way, from looking at them, that you can tell which is which.

One of the SPRITES takes up position in

front of the left-hand door, and one stands in front of the right. They may disappear into thin air at any second, so you quickly ask the one before the right-hand door,

“Are you a Gar?”

“One of us,” he says smugly, “is certainly a liar. Or perhaps we both are!”

Quickly you ask,

“Is the door behind you the door to life?” As they shimmer and disappear, you can just make out his answer – “Yes,” floating in the air.

Now, will you take:

The left-hand door?

Turn to **22**

The right-hand door?

Turn to **143**

178

You go North, and after a short time the passage turns East. You follow this passage until you reach the foot of a stone staircase. Warily, you begin climbing. The stairs take you upwards, in a wide circle, until you go forwards into a short corridor. Turn to **23**.

179

After twenty paces or so, you realise that this is a dead-end. You can find no secret passages, and the only thing to do is to go back. You go back South, until you reach the junction again. Will you:

Go East?

Turn to **33**

Continue South?

Turn to **197**

180

You begin to feel uncomfortable as you walk, fearing everything but seeing nothing. There is a passage to the South. If you wish to go South, turn to **123**. If you would rather continue West, turn to **175**.

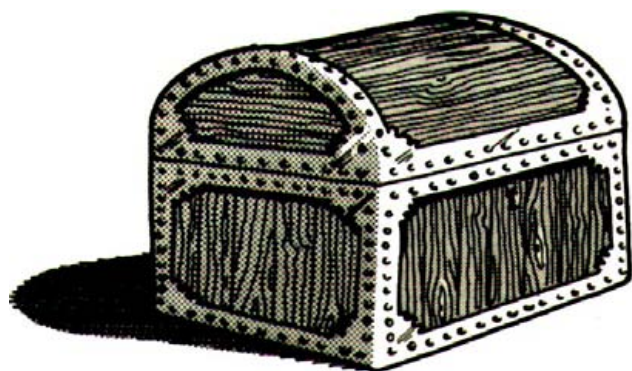

181

It is eerily silent as you walk along, and you have the creepy feeling that you are being watched. You continue, warily, but nothing happens and you arrive at a junction. Will you now go:

West?

Turn to **194**

East?

Turn to **170**

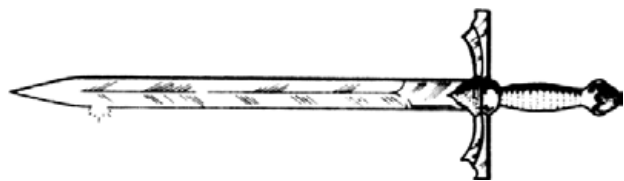

182

Some way along the passage, you see a door on your left. It is set back a little from the passage wall, and seems to be made of some kind of rock itself. If you wish to try the door, turn to **21**. If you would rather continue North, turn to **193**.

183

You continue West for a while, until you notice that you are passing under an archway of stone. The darkness feels heavier, even more oppressing, but you can just make out a heavy wooden door in the wall opposite. You move cautiously round the walls of the small room you find yourself in, and try the door, but it is firmly shut.

You move back towards the archway, but as you do, your foot catches on something. You stagger back – you have stepped on what looks like a corpse that has been there for some time: the flesh is rotting away from the bones, and maggots are crawling out of its mouth.

As you instinctively move away, its eyes suddenly flick open, and it moves towards you. You back away in terror – lose 2 Courage points.

The yellow eyes gleam as the ZOMBIE reaches out for you. You swing your sword, but to no avail. The ZOMBIE is not vulnerable to ordinary weapons, nor is any Potion of Magic any use against this terrible creature. Do you have a silver lance? If so, turn to **29**. If not, turn to **165**.

184

You float away from the floor, watching it tilting and sliding crazily below you, and land safely on the other side. Turn to **53**.

185

The door seems to be locked. You take a pace back and give the door a straight kick, as taught you by Eleutheria. It crashes away from its hinges, and you brush it aside to find yourself in a very small, seemingly empty, room.

You are about to leave, since there is nothing of value, when you hear a strange sound, like glass tinkling. You stop, and look, but there is nothing to be seen. As you stand there, the sound becomes more rhythmic, and starts to form a pattern. It is, you feel, a voice, and as you strain to listen, the crystal sounds suddenly take shape in your mind:

“Go North, and then West,” says the voice. You remember this, wondering whether or not to believe it, and leave the room, going North. Turn to **66**.

186

Going East, you see a door on your left. Will you:

Try it? Turn to **132**
Continue? Turn to **36**

187

You have gone along the tunnel for only a short distance before it ends at a junction. Will you now go:

North? Turn to **146**
South? Turn to **161**

188

You charge the door, and hack at it with your sword, but all in vain. Without the correct key you can go no further, and your adventure ends here.

189

Will you take a Potion of:
Duality? Turn to **118**
Power? Turn to **85**
Elusiveness Turn to **18**

190

The door opens into a tiny room. There is a stone bed against the wall, and a broken wooden chair, but nothing else. You are about to leave, when you notice some writing carved into the wall opposite, and you go closer to see what it says. You read:

“There was another such as you,
he holds the Amulet of Stone –
and keeps it safe for others who
will venture further – quite alone.”

You puzzle over the meaning of this rhyme, before leaving to go North again. Turn to **173**.

191

He lets out a great roar of anger and confusion as you disappear before his eyes, and begins swinging wildly with the great bone. Although you are invisible, you are not invulnerable, and the narrow passage makes it difficult to slip past him. And the effects of the Potion do not last for very long. You try to run past, but a mighty blow from the huge bone catches you on the shoulder, numbing your arm. Lose 3 Strength points. You cry out, and the GIANT swings again, catching you between the shoulder blades as you get past and run North away, from him. Lose 3 more Strength points. His roars fade into the darkness behind you, as the Potion wears off, and, if you are still alive, you lean against the rock wall to get your breath.

When you feel ready, you continue North, and shortly arrive at a junction, where a new passage leads East. Will you:

Take the way East? Turn to **3**
Continue North? Turn to **182**

192

The door opens easily. You are in a very small room, which contains nothing but a broken wooden chair and a stone bed. But some writing carved into the wall opposite catches your eye, and you look to see what it says. You read:

“There was another such as you,
he holds the Amulet of Stone –
and keeps it safe for others who
will venture further – all alone.”

You are not sure whether this is a warning, or useful information, but you memorise the words before leaving to go South again. Turn to **7**.

193

Fairly soon you arrive at another junction – a passage leads off to your right. Will you:

Take this new passage East? Turn to **5**
Continue North? Turn to **44**
Take a Potion of Searching? Turn to **35**

194

You soon come to another junction, where the passage runs North-South, and you turn North. Turn to **182**.

195

As you approach the writing, you set off a hidden trap, and you are immediately engulfed by choking, acrid smoke. You stagger back out, gasping for air. Lose 3 Strength points. If you are still alive, you get your breath back and continue West. Turn to **89**.

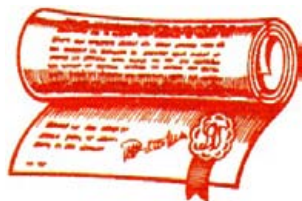

196

The passage narrows as you walk, and the air feels clammy and cold. Your footsteps echo, and your torch flickers, and quite soon you see a new way on your right. Will you:

Take the new passage North? Turn to **181**
Continue West? Turn to **166**

197

You soon find yourself back at the door you first came through. The only thing to do is to turn round and go back North again. Turn to **150**.

198

You move, exhausted, to the great corpse, and find, around his neck, a diamond and sapphire. You realise that these must be the two jewels from the Temple of Valadon, that Golfreth told you of. You go back out of the room, your sword at the ready, but all is quiet.

You go back down the stone staircase, and continue, past the cell that held Swiftfoot, and on down. No creature bars your way: now that BELENGHAST is dead, his power is lost, and his creatures have shrivelled back into the evil half-world they came from.

You eventually get back to the entrance to the Tower of Terror, and are amazed to see that the sun is just setting. You hold up the diamond and sapphire, and shout, "I have the two jewels from the Temple of Valadon!"

The town gradually becomes quiet. Someone moves towards you and you reach for your sword – but then you recognise him as Golfreth, now reformed as a whole man again. Golfreth takes the jewels, thanking you quietly, and walks into the rained Temple. Turn to **199**.

199

Suddenly the sky changes – it is the most glorious sunset you have ever seen, and you realise that the dark clouds hurrying away are the shapes of evil spirits leaving Darkblood.

Golfreth returns.

"I have replaced the sacred Jewels," he tells you, "in the Temple of Valadon. Will you stay?" Turn to **200**.

200

You decide that it would be a good idea to stay for a short while with Golfreth and the others, to rest from your exertions . . . until you feel that the time is right to venture forth again – on a new quest.

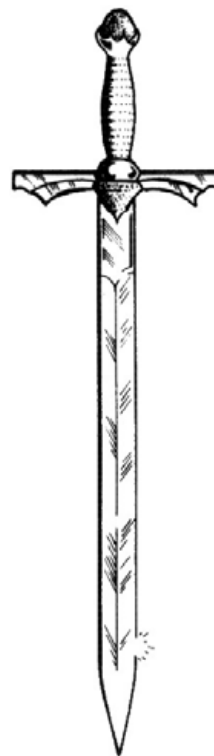

PROTEUS was an ancient Greek God who could change his form to avoid foretelling the future, so you can see our scope for adventures is endless.

If you have any comments on the magazine, ideas for adventures, or if you would like to contribute an adventure game text (payment would be in the region of £500), please write to **Proteus, IPC Magazines Ltd, Westover House, West Quay Road, Poole, Dorset BH151JG. Tel. 0202 671191, ext 261.**

PROTEUS

A Complete Fantasy Adventure Game Magazine

*Watch out for
PROTEUS n° 2...
another complete
solo fantasy
adventure game in
which you play the
role of the Hero!*

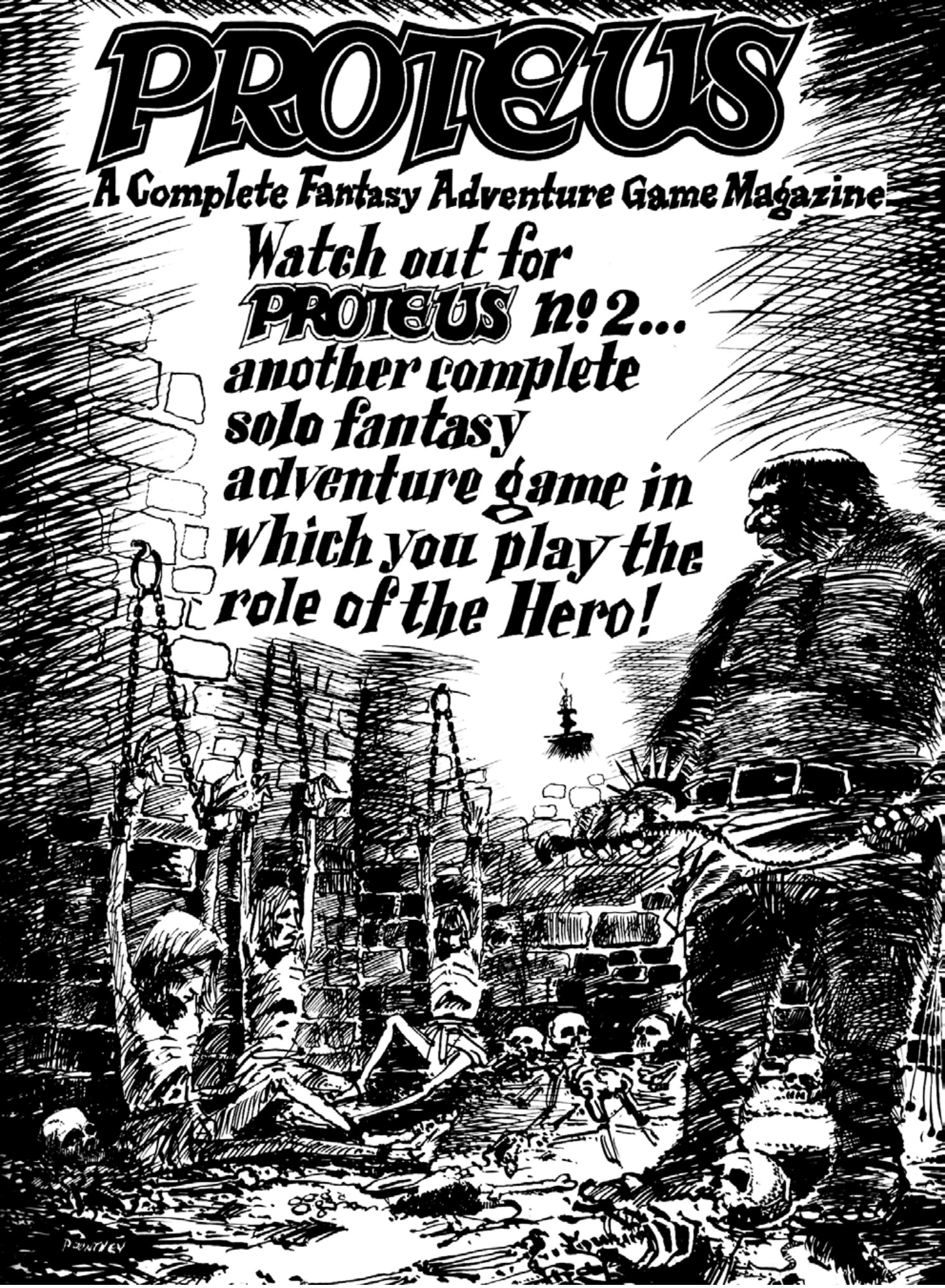



PROTEUS IS A NEW KIND OF MAGAZINE — A COMPLETE ADVENTURE STORY IN WHICH YOU, THE READER, PLAY THE PART OF THE HERO