

# STAR FLEET BATTLES

## CAPTAIN'S LOG #16

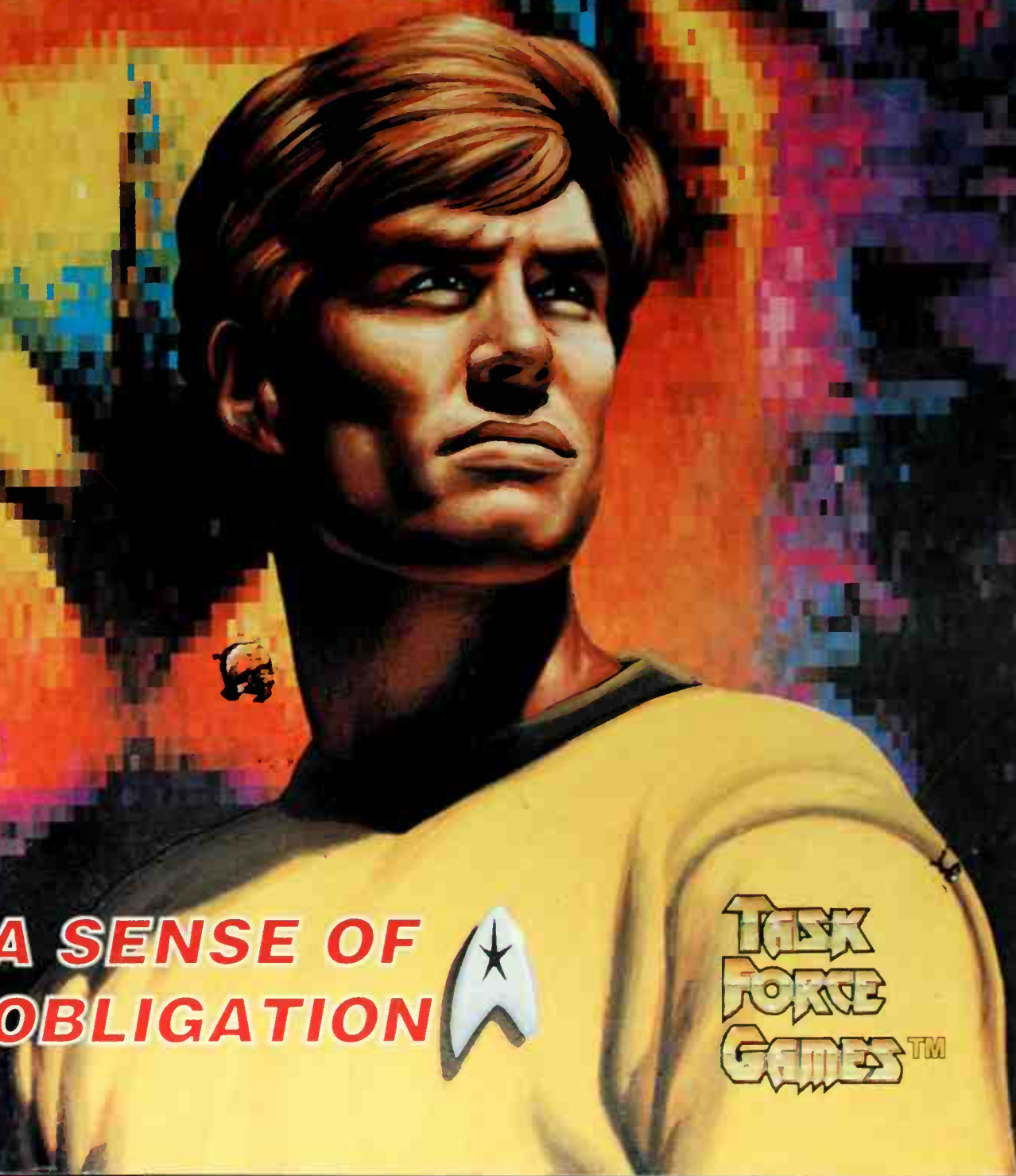

**A SENSE OF  
OBLIGATION**



**TASK  
FORCE  
GAMES™**





# STAR FLEET BATTLES

# ENERGY ALLOCATION AND SHIP RECORD FORM

SHIP / COUNTER	1	2	3	4	5	6	7	8	9	10
1. WARP ENGINE POWER										
2. IMPULSE ENGINE POWER										
3. REACTOR POWER										
4. TOTAL POWER AVAILABLE										
5. BATTERY POWER AVAILABLE										
6. BATTERIES DISCHARGED										
7. LIFE SUPPORT										
8. ACTIVE FIRE CONTROL										
9. CHARGE PHASER CAPACITORS										
10. PHOTON TORPEDOES										
	A									
	B									
(SENSOR CHANNELS) (1)	C									
	(2) D									
	(3)									
	(4)									
11. ACTIVATE SHIELDS										
12. GENERAL REINFORCEMENT										
13. SPECIFIC REINFORCEMENT	1									
	2									
	3									
	4									
	5									
	6									
14. ENERGY FOR MOVEMENT										
HET										
EM										
BRAKING ENERGY										
15. DAMAGE CONTROL										
16. RECHARGE BTTYS / (Resv Wrp)										
17. TRACTOR / NEGATIVE TRAC										
18. TRANSPORTERS										
19. ECM										
ECCM										
LABS										
CHARGE WILD WEASEL										
SUICIDE SHUTTLE										
20. TOTAL POWER USED										
21. BATTERY POWER USED										
PHASER CAPACITORS CHARGED										
PHASER CAPACITORS USED										
MOVEMENT PLOT / NOTES										

SHIP Date:

Race:	Class:	Counter:
Player:		Notes:

GUARD ASSIGNMENTS

DAMAGE CONTROL

SYSTEM	POINTS	NOTES

IMPULSES WEAPONS WERE FIRED

	1	2	3	4	5	6	7	8	9	10
1										
2										
3										
4										
5										
6										
7										
8										
9										
10										

T-BOMBS

HEX	TARGETS	NOTES

SEEKING WEAPONS, SHUTTLES

TYPE	TARGETS	DAMAGE



**A WHOLE NEW LOG!**

As you can see, this issue of Captain's Log is considerably larger than previous issues, and we think it is much better.

We held the old \$10 price point as long as we could, and when inflation meant we had to go to \$11 or \$12, we decided to go to \$15 and give you *MORE* for the higher cost, rather than just giving you a higher cost.

The new 96-page format will give you more of everything, and the "special bonus" (in this issue, a 16-page SSD book of Frax ships) will always be exciting. Future issues may have a map or countersheet instead of the SSD book; all will have a few SSDs.

This issue also inaugurates the new "mini-theme" concept with three good ones: Jindarians, X-ships, and Alliance Maulers! Each mini-theme is supported by various articles throughout the issue.

*Captain's Log will never be the same!*

**CAPTAIN'S LOG STAFF**

Editor-in-Chief ..... Stephen V Cole  
 Executive Editor ..... Leanna M Cole  
 Managing Editor ..... Steven P Petrick  
 Publisher ..... John Olsen  
 Producer ..... Timothy D Olsen  
 Star Fleet Committee ..... Ray Olesen,  
 Keith Velleux, Tony Zbaraschuk  
 Star Fleet Staff ..... John Berg, Bruce  
 Graw, Jeff Laikind, Gregg Dieckhaus,  
 Spence Cocherl, Gary Plana, Chuck  
 Strong, Jon Cleaves, Scott Mercer, Ken  
 Burnside, Cliff Yahnke  
 Cover Painting ..... David Martin  
 Art on Page 21 ..... Greg Breault  
 Other interior art ..... Dan Carroll  
 Computer Art ..... Stephen V Cole  
 Chief of ADB Security ..... Blackie  
 ADB Security Staff ..... Waylon, R Rex  
 Printing ..... Dallas Offset  
 Cover Printed by ..... Trafton (Amarillo)

**PUBLISHER'S INFORMATION**

Captain's Log #16 was created by Amarillo Design Bureau and published by Task Force Games, Post Office Box 50145, Amarillo, TX 79159. Contact Task Force Games to order spare parts (or to obtain a list), replacement of defective or missing parts, or anything relating to TFG products other than Star Fleet products. Include a stamped self-addressed envelope.

Captain's Log #16 is copyright © 1994 Amarillo Design Bureau; all rights are reserved under the Pan-American, International, and Berne Copyright Conventions.

All rules questions and submissions of new material should be sent to ADB, Post Office Box 8759, Amarillo, TX 79114. Be sure to include a stamped self-addressed envelope if you wish a reply. Unsolicited submissions are accepted only under the standard terms found in SFB Advanced Missions. Others should inquire by letter.

**TABLE OF CONTENTS**

**HISTORY**

A Sense of Obligation *by Bruce Graw* ..... 2  
 Universe Notes ..... 9

**DATABASE**

Star Fleet Communications Center ..... 10  
 Rated Aces; Star Fleet Service Awards ..... 14  
 Building a Better Log, Input Guide; Playtest Update ..... 15  
 After Action Review ..... 16  
 Command the Future, Miniatures are Back! ..... 17  
 New Ships ..... 18  
 Decisions of the Star Fleet Universe Board of Proposals ..... 18  
 To Ask the Question: *Why?* ..... 19  
 Ask Kommodore Ketrick: Rules Questions ..... 20  
 Could You Give Me An Example of... *by Bruce Graw* ..... 22  
 Battle Force 1400: Stop the Jindarians! ..... 24  
 Building an SFB Group ..... 26  
 Ten Good Questions ..... 29  
 101 Ways to Kill a B10 ..... 30  
 Play Aid: New Energy Record Form ..... Inside Front Cover

**UNIVERSE**

Prime Directive: The Vudar Enclave ..... 31  
 Star Fleet Missions: Three New Missions, Three New Variants ..... 32  
 Star Fleet Warlord ..... 33  
 Art Gallery ..... 36  
 The Frax ..... 37

**SCENARIOS**

SL148 A Sense of Obligation ..... 39  
 SL149 Stop the Jindarians! ..... 41  
 SL150 Interceptors ..... 42  
 SL151 Q-Incidence ..... 43  
 SL152 A Nest of Vipers ..... 45  
 SL153 Stalking *Siegebreaker* ..... 46  
 SL154 The Mulakee ..... 47  
 SL155 Hotter than Blazes ..... 49  
 SL156 Slugfest ..... 50

**TACTICS**

The X-Ship Seminar ..... 52  
 Term Papers ..... 54  
 Victory At GenCon 94 *by Bill Albert* ..... 60  
 Ask Uncle Ardak ..... 63

**ENCYCLOPEDIA**

Star Fleet Universe Index ..... 64

**FEDERATION & EMPIRE**

In This Empire *by Jeff Laikind* ..... 83  
 Federation & Enquire ..... 83  
 Alliance Maulers in F&E ..... 83  
 Tactical Notes ..... 84  
 Scenario 691: Federation Warlords ..... 86  
 Balancing Fleets in the Free Campaign ..... 87  
 Total War Preview: Casual PF Flotillas ..... 88  
 Allowed Substitutions List ..... Inside Back Cover

**NEW SHIPS FOR STAR FLEET BATTLES**

Jindarian Shipyard Cruisers, New X-Ships, Maulers ..... 89-96  
 The Frax SSD Book ..... S1-S16

Elements of the Star Fleet Universe are the property of Paramount Pictures Corporation and are used with their permission.



## A SENSE OF OBLIGATION

by Bruce Graw

### Bridge, Federation CA *Ramilles* At the Federation-Tholian Border Y166

"Border warning buoy ahead, Captain," said the helmsman, turning her head with a half-questioning, half-warning glance. "Last chance to turn back."

"No, proceed as ordered," Captain Sven Fregessan replied, leaning back in his chair and trying to look unconcerned. They were only crossing the Tholian border, an act that violated several treaties and could potentially be a political nightmare for the Federation. But his superiors had given him the go-ahead for the rescue, and he was more than happy to comply. More than happy.

The lights dimmed slightly as the ship settled into full silence and crossed the border. Sven felt a chill run up his spine, reflexively anticipating some sort of immediate response, but nothing happened and he forced himself to relax. As expected, there were no Tholian ships in the immediate vicinity. With any luck there wouldn't be any near enough to stop him before the *Ramilles* had done its job and gotten out again.

He glanced around at the rest of the bridge crew, watching them go about their duties steadfastly and without question. He felt a twinge of guilt, then, over what he was having them do, but it faded as quickly as it had come. His reasons for undertaking this mission were his own, and even if it meant the end of his career, he was going to succeed and repay the debt he owed his brother.

How well he remembered the day when he first learned of his brother's fate . . .

### Rec Room, Federation Destroyer *Xerxes* Y159

"You're getting much better, Sven," said Charlie Rivers as she parried Fregessan's saber with the finesse of a master.

"Not good enough yet," he puffed, already growing exhausted. He feinted once and slashed downward at her leg. She blocked the attack and riposted back, missing only because he backed out of her reach, catching his breath for a moment.

Charlie didn't press the attack, for she wasn't out to win this battle. She could have done that at any time. Actually, she was trying to instruct him on some of the finer points of swordplay. She was a fair-haired, pretty ensign straight out of the Academy, but what impressed Sven more than her good looks was her deadly skill with the blade. He had never seen anything like it.

Sven had always thought himself good at the sport, although he'd never actually entered competition. Despite his skill, Rivers had made him look like a rank novice the first time they sparred. He was yet to defeat her in a fight, and today would not be the first time, he realized. With an audible gasp, he finally gave in to his exhaustion and lowered his saber. "I've had enough," he managed as he removed his face mask. "You've worn me out. Again."

"So what's new?" she laughed, returning her own blade to the rack. "I'll work you into shape one of these days."

"Sure, go on, pour some salt in the wound, Miss All-Academy Fencing Superstar."

She laughed again, and he joined in now that he'd caught his breath. He was still chuckling when he heard the door swish open and saw the captain come in, his expression dour and sullen. The expression of gloom silenced Charlie and Sven's

laughs almost immediately and, although he wasn't yet aware of the fact, also signaled the end of Sven's life as he knew it.

"Sir?" Rivers asked as Captain Speerin approached, but he passed her by and walked straight up to Fregessan.

"Lieutenant," he said solemnly, "I'm afraid I have some bad news."

"What is it, Captain?" he asked, feeling his heart already sinking as he spoke.

"It's your brother . . ."

### Observation Deck, Federation DD *Xerxes* Y159

He heard the footsteps behind him, but didn't move from his position, staring out at the endless starscape on the other side of the window. Silently, he wished whoever it was would go away.

"Sven?" Charlie Rivers asked, stepping up next to him lightly and looking at him with genuine concern.

He didn't move, so she went on, her voice low as though she feared she might awaken a light sleeper if she spoke too loudly. "Sven, I just want you to know . . . if there's anything I can do for you."

He turned to look at her, and she met his stern gaze with solid reassurance. Something mirrored there caused him to relax, to choke back the harsh "Leave me alone!" he had nearly uttered. "Thank you," was all he could say.

"I can feel for your loss," she went on, doing her best to comfort him. "My sister and I were very close, and when she died . . . I guess I felt like you're feeling now."

"You can't understand," he replied, and it was so low it was nearly a whisper. "My brother—" He choked for a moment and then recovered. "When my parents died in that shuttle crash, he kept the family together. I was the youngest, and he all but raised me on his own. He's the reason I joined Star Fleet! And now he's gone—disappeared, and they don't even know what happened!"

"I'm sure there's some reason."

But he was already growing angry. "How can a freighter just disappear into thin air? Why didn't they tell me anything more? What kind of notification was that? It's not fair!"

"Sven, I know you want to lash out at someone right now, but that's not going to help."

His fists were clenched in rage, but at her touch, he lowered them back to his sides. "I know," he told her. "And I appreciate you coming up here, but right now . . . right now, I just need to be alone for a while."

"I understand." She turned and slipped away, but stopped at the door. "Just remember, I'll be here if you need someone to talk to."

"Thank you," he replied, but she was already gone, leaving him alone with his thoughts . . . and his memories.

### Bridge, Federation CA *Ramilles* Y166

Sven remembered that time most vividly. Had it not been for Charlie Rivers, he doubted he would have gotten through the night. As much as he thought he had needed to, he hadn't spent it alone.

Friendship was a funny thing. He'd never thought of Charlie romantically before that night, and never again afterwards, but she had been there for him when he needed her, as she'd promised. Perhaps he had made some mistake along the way, missing an opportunity to make more out of their relationship, but both of them had known, somehow, that they would never be more than friends. The memory of his brother hung heavily



over him then, like a shroud, and had done so ever since that day.

He had no idea where Charlie was now, but silently he wished her luck with her life and thanked her for what seemed like the millionth time.

"Captain," said a voice, interrupting his thoughts. "I have two incoming calls, sir."

Fregessan turned to the communications officer, Earl Blankenship, whose expression showed not the slightest trace of excitement or worry over what was to come. Sven wished he could hide his own emotions equally well; he knew his own face betrayed his anxiety. "Who's the first one?" he asked, absently wiping away the sweat from his palms.

"Lieutenant Commander van Meers, sir."

"Put him on audio."

"Captain," came the deep, resounding voice of Harrison van Meers, leader of *Ramilles'* Redoubtables, the ship's Prime Team. "I just wanted to know if you had any last-minute orders."

"None," Sven replied, managing a smile. He liked van Meers and was secretly jealous of the man's ability to be in the thick of the action while he was all-too-often left behind at the helm. Today that feeling was all the more prominent. He truly wished he could be part of the rescue team, although he knew that was impossible.

"I just wondered if Star Fleet might have had a change in plans," van Meers went on. "Sending us into Tholian space like this is awful risky."

Fregessan almost cringed visibly; that comment had hit too close to home. Steeling himself, he tried to sound unconcerned as he replied, "Nope, the mission's still a go. Everything ready on your end?"

"Of course, Captain," he replied. "The last of the pressure suits is configured for Tholian conditions. Six of the other boarding parties are equally prepared, as are the two Marine Strike Teams and the Redoubtables."

There was no point in rehashing the mission requirements, although Sven quickly went over them once again in his mind. Charge the base, get in close, find the prisoners, get the teams aboard, make the rescue, and dash out again before any defending ships could arrive.

It all sounded so simple.

"Did you need anything else, Harry?" Sven added after a moment's pause.

"No, Captain. Van Meers out."

Sven started to settle back into his chair. "The other call, sir," Blankenship reminded him. "It's Commander Rochelle."

Fregessan's shoulders slumped visibly. Walt Rochelle was his second-in-command, stationed in the Emergency Bridge in case of an accident on the Main Bridge during the upcoming battle. While this was not standard fleet procedure, Sven had insisted on it for this mission—but then, he had a reason, of course. "Put him on."

"Captain," said Rochelle's gruff voice, "we need to talk. Now. In private."

"What? You can't be serious! We're already in Tholian space!"

"We still have fifteen minutes before we reach the base, and this is important. Come to the briefing room. Now."

The statement left something behind, a hint of a threat, and Sven thought better of refusing to come, even though he easily could have. Standing, he said, "I'm on my way. Mitch, you have the conn, but I'll just be a minute."

"Aye, Captain."



#### Briefing Room, Federation CA *Ramilles*

Fregessan stepped into the room, dreading what he half-expected to see: an armed security team ready to arrest him. But there was only Commander Rochelle. The tall, gaunt man, graying at the edges as he entered his mid-forties, had a look of half-anger, half-sadness in his sunken eyes. He was standing at the end of the table with arms crossed, waiting.

"What's so important, Commander?" Sven asked, trying to sound nonchalant. "I've got a mission to run."

"You know what it is," Rochelle replied evenly.

"Just for the heck of it, why don't you tell me?"

"The message to Star Fleet Command. About the distress call."

Fregessan's heart sank like a stone. Rochelle knew.

The commander seemed to read his thoughts. "I looked into your message logs," Rochelle told him. "I have that authority, you know, in case the captain begins to act strangely. It's one of those little safeguards Star Fleet built into the system."

"I know that," Sven spat. "Don't be condescending."

"After you briefed us on what we were doing, I couldn't believe Star Fleet would risk something like this. Everyone else bought it, but it goes against everything I've been taught. So I checked. The message you claimed we received was falsified. There is no mission. You made it all up. Why?"

"If I told you, would it really matter?"

"Not really."

"Then why are you asking me?"

"I wanted to give you one chance."

"A chance? For what?"

He took a step forward. "Sven, I've known you for two years now. You're a terrific captain, and I consider you a personal friend. But this isn't right. You're risking the ship and crew on your own vendetta. That's what this is about, right? Some kind of vendetta?"



"Well, I can't sit by and allow this to happen. But if you turn back now, tell everyone Star Fleet has called it off, maybe we can cover it up somehow, or at least avoid a court-martial."

"Walt," Sven replied, "you and I both know my career is over, win or lose. It's too late for any of that."

Rochelle didn't reply, only bowed his head slightly in affirmation.

"Let me tell you something," Fregessan went on. "When I was just a boy, my parents were killed. My brother, Hans, raised the rest of us. I followed him into Star Fleet. I owe him everything. And then, he was taken by the Tholians seven years ago. I know he's still alive, and I have information that tells me he's at this very base, right now. This may be my only chance to see him alive again."

Walt looked at him curiously. This was something he hadn't known, something Sven had kept a very careful secret. "Why didn't Star Fleet—?"

He shook his head. "They could do nothing. Hans was on an intelligence gathering freighter. You remember the negotiations, getting the Tholians to close the border to the Klingons and Roms? If the Federation admitted Hans and his ship were there, spying in Tholian space, those negotiations would have been jeopardized. So they refused to acknowledge the freighter. They gave everyone up as lost."

"But look at what was accomplished!" Rochelle told him. "Keeping the Klingons and Romulans apart may well have saved the Federation from a devastating war! Hans sacrificed himself for that!"

"He didn't sacrifice himself!" Sven all but shouted. "He was sacrificed. There's a difference. But none of that matters. I know he's alive, and I have to do something about it. Can't you see? The bond we have transcends everything else—even my oath to Star Fleet."

"If my brother made a sacrifice, as you say, for the Federation, then the least I can do is make a similar sacrifice on his behalf."

Rochelle slumped slightly. He had seen the intensity in Sven's eyes, and knew then that no words he could speak would sway his captain from this fool's errand. *Oh well*, he thought, *it's not like I didn't try*. He reached for his phaser and opened his mouth to tell Fregessan he was under arrest.

Sven's arm moved faster than Rochelle had ever dreamed possible, and quick as a whip the captain had drawn his phaser, aimed, and fired a single blast. The commander, a look of stunned surprise still on his face, crumpled to the ground.

Fregessan replaced his phaser on his belt. "You'll be safe here until this is all over," he muttered, thanking Charlie Rivers once more for her endless fencing lessons. Though he'd never beaten her with a sword, at least his reflexes had been honed to razor-sharp perfection.

Turning his back on Rochelle's limp form, he headed back towards the bridge.

#### Turbolift, Federation CA *Ramilles*

He hated having to stun Commander Rochelle, especially since the commander's presence might be missed down in the Emergency Bridge, but he'd recover everything but his pride. Sven would have to make sure he testified at the court-martial that Walt had done everything he could to stop him. No sense in ruining two careers at once.

Still, Rochelle's words had disturbed him. "You're risking the ship and crew on your own vendetta." What if someone died while the mission was on? No! He forced himself not to think about that. This was no time to be weak. He pushed all his fears

and doubts from his mind, letting his thoughts drift back to how this all began.

Shortly after he'd recovered from the initial blow of the loss of his brother, he made some inquiries into what had happened. Information was sketchy, but he dug further at every opportunity. Eventually, the truth about the intelligence-gathering (i.e., spy) mission came out. While he could understand the Federation's motives in avoiding the issue, he didn't have to like them. He vowed, then, that he would do everything in his power to rescue his brother, if such a thing were possible.

For the next six years, he did everything he could to keep himself stationed near the Tholian border. He questioned traders, secretly monitored transmissions, and followed all the intelligence reports coming out of Tholian space, but he never had a lead on his brother until just a month ago. It was then that he learned about the new base.

Just a few parsecs from his own ship's patrol route, the Tholians were constructing a new base station. Intelligence reports told him they often used prisoners for most of the "outside" work, because Tholian physiology required overly bulky spacesuits to maintain the higher pressures and temperatures that kept them alive in the cold of space. This meant the only way for them to work on the exterior of a spaceborne project was to use sophisticated robots or vehicles with manipulator arms, both of which were terribly expensive. Humans (and other captured races) did the job quite adequately, however, and in simple, cheap spacesuits. Plus, there was nowhere for a prisoner to escape in open space, so security was hardly required.

With the news of the new base, Sven bribed several traders to check into the prisoners' identities, although he didn't hold out much hope for success. But one of the traders had somehow gotten onto the station, dealing in some sort of mineral which the Tholians apparently found rather intoxicating. While there, he glimpsed some of the prisoners and claimed that one of them had blond hair and very pale, freckled skin. Furthermore, while he had not been able to speak with the prisoner, the trader had heard his voice from a distance and recognized the same traces of Nordic accent which lingered in Sven's words when he spoke.

The trader wasn't lying; Sven could tell that. He hadn't told him what to look for, but he had come back with just the sort of detail he needed. The prisoner could be his brother!

Not "was," but "could be." Still, that was all Sven had asked for, and more than he could have ever hoped.

Now they were going in, and he uttered a silent prayer that it was really Hans. Nothing else mattered.

The bridge doors slid open, and Sven stepped in, glancing at the chronometer as he made his way to his seat. Two minutes to go. He'd deliberately delayed his return so that no one would miss Commander Rochelle until it was too late.

"Sir," said Alex Bowen, the weapons officer. "I have the weapons downcharged to non-violent levels, as you ordered. Are you sure that's—?"

"This is a rescue mission, Lieutenant," he replied crisply. "We're not here to kill the Tholians, but to rescue our hostages."

"But the suicide shuttles, sir?"

"They will be used to down shields, nothing more."

"Very good, sir."

"Base is at 500,000 kilometers, Captain. At least, that's what I think it is. Hard to tell with passive scanners."

"They won't be passive much longer. Bring us up to warp two point nine-six." He knew this was the fastest the ship could go on standard photons and with two suicide shuttles in the bay. "Sensors, go active; I need to know what's out there."

"Aye, sir." There was a brief pause. "I see nothing but the base, Captain."



"Excellent, but you know as well as I there are always Tholian ships around somewhere. Keep an eye out. Now, Emily, this next part is important, so listen carefully."

"Yes, Captain," the scanner operator replied. "I'm all ears."

"When we reach 300,000 kilometers, Mr. Bowen is going to start arming a probe for information. We will begin slowing down when we are at 100,000 and divert power to electronic counter-countermeasures. Use this power to clear your screens and tie into the probe systems. It's going to be launched at the base, and you need to find those prisoners with what it tells you."

"Aye, Captain."

"Good. Did you get that, Mr. Bowen?"

"Yes, sir!"

"Range?"

"Four hundred fifty thousand and closing."

"Arm probe at 300,000 kilometers."

"Captain, incoming communication from the base. They demand to know what we're doing here."

"Ignore it. No reply on any channel."

"Aye-aye."

"Sir, the base is coming active. I see fire control coming up, and we have a shuttle launch."

"Damn. Those shuttles are going to be a problem." He cursed himself. He hadn't thought about Tholian shuttles. If he blew them up, that would cause casualties, and he didn't want this to be a Tholian slaughter. But if he left them out there, they'd shoot his ship every time he lowered a shield for a boarding action. What could he do?

"Three hundred thousand," came the announcement, interrupting his thoughts. He tabled the shuttle issue for later.

"Probe arming, sir. Speed decreasing slightly."

"Good."

"Base is launching another shuttle. The two are approaching us at warp 1.8."

"When we slow, put some reinforcement up front."

"Can do."

"Two hundred thousand kilometers."

"I'm picking up broadcasts now. Distress calls, I think."

"Just now? They're awful slow."

"There's another on the continuous band. This one's just giving more information about us."

There was no point in trying to jam the communications; his ship didn't have the power to overcome the base's channels. "Divert power to ECCM at one hundred thousand. Roll the photons up to overload strength."

"Executing."

"Fire probe."

"Probe away!"

The missile shot forth from the ship, burning out an instant later 60,000 kilometers ahead, but it had done its job. "I've got it, Captain. Scanning now. It's a clear view. The base is generating only low-level jamming, Captain."

"Keep our counter-jamming at full. They do have batteries, and I don't need to fire through a cloud of static. Bring us down to warp 1.8, and reinforce the forward shield. Get ready to launch those pseudo-suicides on my order."

There was a chorus of ayes. "Wonder where the other two Tholian shuttles are," someone muttered.

"Shuttles firing." There was a momentary flare. "Damage bounced off reinforcement, sir."

"Good."

"Base is firing. Four heavies." There was a slightly larger flare as the phasers cut into the shield. "Shield down 20 percent."

Sven watched the action on the viewscreen. The two shuttles showed up momentarily as bright dots, then flew past as the ship went right on by them and up to the base. The base itself

looked like a hodgepodge of modules clumped around a central core in the classic mobile base style. He hoped none of the pods were more than simple cargo modules. "Prepare to fire at 20,000 kilometers. No need to feedback on ourselves! Do I have those overloads yet?"

"Aye, sir."

"Then fire!"

The photons spewed out of the tubes, all four of them impacting on the base's facing shield and blowing it completely down. A couple of flashes scored on the base's interior, but the extra energy, instead of flowing into the station, seemed to scatter away. Non-violent weapons were like that, designed not to destroy but to short out equipment, especially weapons.

"Minor damage, Captain. Two phasers, the light ones."

"Good. Bring us to full stop at 10,000 kilometers. Phasers, fire a full strike. All guns."

The phasers followed the photons through the downed shield, but instead of ripping great gashes across the hull, they merely danced over the surface, sending bursts of energy haphazardly about but seemingly not truly harming anything. Still, some damage was caused, but usually by overloading sensitive electronics and burning out critical conduits rather than with the rampant violence that normally accompanied a phaser blast. "Direct hits, sir, but only two phasers went out. All the ones that face us."

"Excellent! Emily? We need those coordinates."

"I have them, sir! Feeding down to transporter rooms now."

Sven pumped his fist with excitement. "Then start the boarding actions!"

"But, sir, there are more people there than there ought to be. I thought we were looking for no more than a dozen; I count at least sixty!"

"Of course, that's because—" He checked himself quickly. What he had told the crew was not everything he knew. He almost smacked himself for not thinking of this in advance; of course there would not be just a few prisoners here. "The Tholians must have other prisoners, too, but I can't guess why. They may not all be human. Try to find out which ones are ours, but we're about to lose our transport opportunity. Send in three regular boarding parties, and try to rescue whoever you find. Pick a group at random. Quickly!"

"Aye, Captain!"

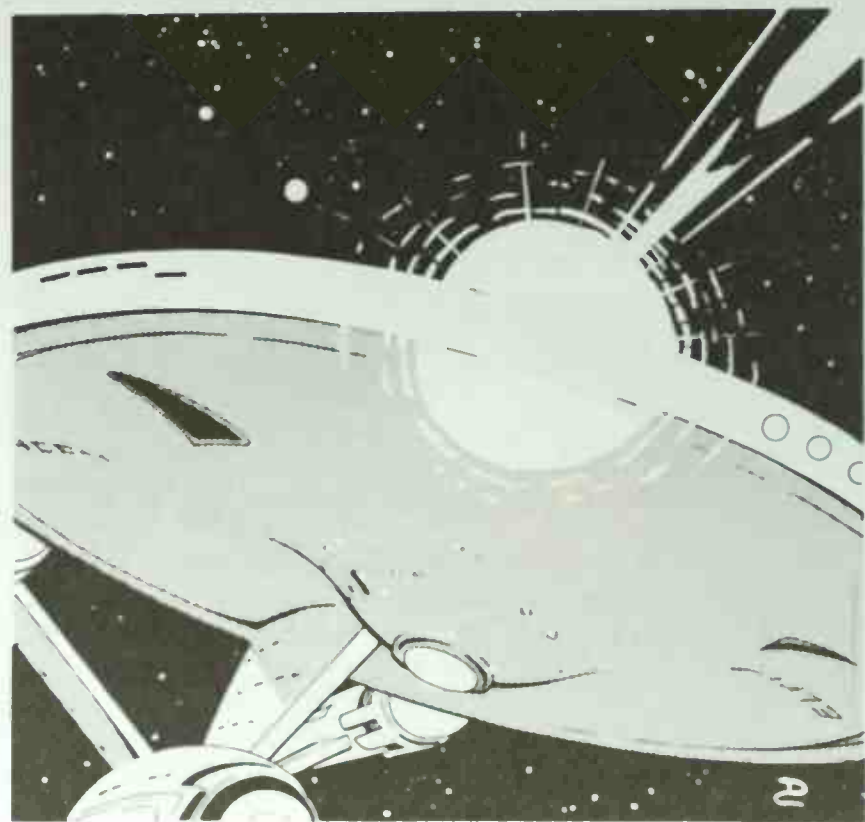



### Holding Pen 24, Tholian Mobile Base Akk-10

Ikkrik moved slowly down the hallway, dragging the huge bulk of the pressure-sealed storage cube behind him. Each day it was more of the same drudgery, hauling food from cell to cell, keeping the prisoners alive.

He often wondered why anyone bothered. It seemed simpler, he thought, to just do away with the fleshy ones entirely, but then, he was looking at it from the viewpoint of one who had to keep them alive. Not that killing them would be difficult at all—just unseal the hatch while they were out of their envirosuits and that would be that. Of course, he would probably be the one to clean up the mess. He gave the Tholian equivalent of a sigh, a slight hissing of vapor from one of his breathing cavities.

When prisoners were captured, there were really only three options available to the Tholians. One was to return them home, but this would be seen as weakness politically. The Klingons and Romulans would certainly see it that way, and the Federation, while not quite so arrogant, would still be able to learn something about the Tholians by debriefing the former hostages. Besides, were they not spying on the Holdfast, or attacking it outright? Did they not deserve to pay for their crimes?

The second option, killing them, was distasteful to most Tholians. Unlike the Klingons and Romulans, Tholians harbored a respect for life that only the Federation seemed to share. While Tholians could be ruthless and cruel, they did so only when needed. There was nothing to be gained by killing the prisoners. Besides, while still alive they could be of some use, replacing expensive machinery whenever possible, and speeding repair and construction operations throughout the Holdfast.

So it was with these prisoners. Ikkrik, for all his complaining, accepted the need and lived with it, although he didn't have to like it.

At last he reached the holding pen he had been shuffling towards. It was the last he would have to deal with this day, and for that he rejoiced. In a short while he would be softening his crust in a cool electrolyte bath, a relaxant he looked forward to immensely.

As he pushed the food container into the heatlock, a klaxon sounded. Ikkrik nearly jumped out of his crust. Attack alert! How could the base be under attack? His mind went several directions at once as the panic raged and finally subsided.



A drill! It had to be a drill. He relaxed slightly and forced the container forward, trying to get it into the heatlock. Something seemed to be blocking it, so he tried several more times until it finally slid into place. He was about to shut the seal and cool the lock when the base suddenly shuddered as if struck.

Ikkrik was starting to realize this might not be a drill when the base rocked even harder. The panic returned, and this time it did not fade. His phaser. Where was his phaser? He didn't have it. There was never any need to carry it. The prisoners could never break out. Escape was impossible!

A shimmering began in the air behind him. Still in the throes of despair, he turned out of sheer reflex. Five figures in white spacesuits appeared, all holding weapons. He managed to recognize the insignia of the Federation on their helmets just before two phaser beams hit him and knocked him into blissful unconsciousness.

### Bridge, Federation CA Ramilles

"Sir, the first boarding parties have returned."

"Excellent. Report!"

"One rescue successful, but it was Romulans they found. The second group reports failure, but they did locate humans, sir. The third group suffered casualties and had to abort."

"Damn." He had to refrain from asking for more details about the second and third groups. He wanted desperately to ask if anyone had seen his brother.

"Sir, the shuttles are coming up behind us. They are firing." The muffled sound of light phasers bouncing off the flank shields could be heard. "Very minor damage. Number three and five shields down 15 percent."

An idea occurred to Sven. "Tractor them and rotate them away," he said, amazed that he had not thought of this before.

"Executing."

"Phasers are recycled, sir. Standing by on shuttle controls."

"Launch empty seeking shuttle."

"Shuttle away."

Sven watched as the small rectangular shape of the shuttlecraft appeared, heading for the base station. Before it could make it, phasers flared and blew it into scrap. Fregessan half-smiled; he had expected this. The base was rotating, and the rest of its phasers had come into position to fire. Better to have them fire at shuttles than at the *Ramilles*!

"Launch second pseudo-suicide," he ordered evenly.

The shuttle appeared and was also subsequently destroyed. The Tholians had saved their phasers for this eventuality, but had guessed poorly and reckoned without the Federation ship's additional shuttles. "Launch suicide shuttle now. Fire four phaser-1s and both phaser-3s at the base just after the explosion, special targeting."

"Only four phaser-1s—? Aye, sir."

"Shuttle away."

The third shuttle moved forward and impacted on the base, exploding in the bright flare of matter-antimatter annihilation. An instant later the *Ramilles*' phasers pelted the base, slicing through what was left of the shield and splattering its hull with rampant energy.

"Two phasers destroyed this time, Captain. The other light ones. Two heavies left."

"Captain! Two shuttles launching from the base, heading our way!"

"I thought so," muttered Fregessan. "Fire remaining phasers, one at each, and make a tactical maneuver to port. Make these shots count, mister!"

"Phasers firing. One target destroyed, one crippled. Sensors register large explosion—a suicide bomb, sir!"



"Brace for impact."

A second later the ship rocked sharply as the Tholian suicide shuttle impacted on the fore starboard shield. This was followed immediately by twin bursts from the last two phasers on the base. "Ninety percent damage to shield, sir. The suicide didn't have a full warhead."

"Fortunately," Fregessan breathed.

"Captain, sensors detecting new entry into the area! Patrol class, range 400,000 kilometers and closing fast."

"Damn, it's too soon! Have you found any human prisoner groups?"

"Aye, sir. Two, possibly three."

"Send in the Strike Teams." He eyed the incoming blip on the screen warily. "Accelerate us to warp 1.6. Now!"

#### Transporter Room Bravo, Federation CA *Ramilles*

Lt. Commander van Meers was wearing a frown, although no one could see it under the bulky helmet and pressure suit. He had watched one boarding party transport away and come back empty, and with casualties. Fortunately it looked as if the three injured crewmen would live. Their suits had been cut or damaged in the fighting, and they were suffering from serious burns, but would probably survive.

Something was wrong here, and van Meers was not sure what it was. He didn't like not knowing things, and that was the problem. As leader of *Ramilles'* Redoubtables, he was accustomed to being fully briefed before any mission. However, the briefing for this had been short and simple, with a lot of explanation of the how and where, but nothing at all about the why.

There were too many "why" questions. Why was the *Ramilles*, of all ships, being used for this mission when a commando ship would be much better suited? The only possible answer was that it was a hastily planned rescue attempt based on time-sensitive information. However, if that were true, why had two commando squads been conveniently picked up by the ship a week ago? Coincidence? In van Meers' experience there was no such thing.

Then there was the real question: Why was the Federation risking their treaty with the Tholians to do this? The Tholians just wanted to be left alone; if they were holding a particularly valuable prisoner, it would be far easier to negotiate his or her release diplomatically. Besides, a prisoner of any value would surely not be part of a base construction crew!

Van Meers had a lot of questions, but no answers. He knew his duty, however. He would do his job.

The signal came. "That's it. Everyone, to your stations!" he ordered over his comlink. "Make sure your weapons are set to stun!"

There were several "ayes" as his team jumped onto the transporter pad. No one made any move to check their weapons, apparently satisfied that they were properly set. This was not surprising, as the Redoubtables knew their jobs well. The skill of a Prime Team is often surpassed only by their pride in their work.

The transporter activated, whisking the Prime Team away in beams of flickering light. The next thing they saw was the dim interior of the Tholian base, illuminated only by their headlamps, which had activated immediately upon arrival. Tholians see only in the infrared and do not use visible light inside their ships.

Commander van Meers turned to survey the area. As he did, several phasers fired at unseen targets. "Two hostiles down," someone, probably Trellis, said over the link.

Van Meers did not even look to see what had happened, trusting the rest of the team to cover all of the approaches.

"Perimeter secure?" he asked.

"Check," came a chorus of voices.

"Get to it, then."

Two of the team moved forward into the heatlock, followed quickly by van Meers. The door shut, and Ericksen, still outside, worked the controls with practiced skill. Through the transparent wall, van Meers watched the rest of the team beam out.

When the temperature had cooled, the inner door in the 'lock opened automatically. A sudden blast of phaser fire greeted them, hitting Wheeler in the shoulder and throwing him back with a yelp of pain. His armored suit saved him, but was partly disintegrated by the shot.

Van Meers, uttering a curse involuntarily, returned fire. There were two figures, both in heavy pressure suits, firing at the doorway from behind a cluster of fear-stricken prisoners. He started to shoot, then paused, afraid he might hit one of the human shields the two Tholians were using. "This can't work," he blurted over his comlink. "Myers! Get those doors shut!"

Myers reached out and worked the buttons on the Tholian control panel, causing the inner doors to slide partly shut. Several more blasts struck them, and one obviously hit a vital component, causing the doors to freeze in place.

There was nothing else van Meers could do from this position, he realized. "Strike One to *Ramilles!* Get us out of here!" he half-shouted as another phaser bolt came through the doorway, missing him by inches.

The acknowledge signal resounded back, and he felt the welcome tingle of the transporter beam a moment later. But reassuring as that feeling was, it didn't chase away the sinking feeling in the pit of his stomach. He had seen something very disturbing, something which answered a whole lot of the questions he'd had about the mission.

One of the prisoners being used as a human shield could have been the twin of Sven Fregessan.

#### Bridge, Federation CA *Ramilles*

"Strike teams reporting in," said Blankenship. "One failure, two successes, Captain!"

"Is my—" Sven stopped himself just in time, fighting down another wave of excitement. "Casualties?" he asked quickly.

"None dead, several wounded. I can hear cheering in the background, sir! What a sound!"

Fregessan wished he could be there, but there was no time for that now. The Tholian destroyer was getting close, already within 300,000 kilometers. "Bring us up to warp 2.4 as soon as possible. Better release tractor on the shuttles. We don't want any death-dragging. Do I have overloads yet?"

"Coming on line in two seconds, sir."

"Excellent. Bring us past the base so that we will pick up one of the down shields as it rotates past us. We'll make one more try at a rescue as we go by."

"Coming into arc in a few seconds, Captain."

"Sir, incoming message from Commander van Meers!"

Oh, no. "On audio. Quickly!"

"Captain," came van Meers' voice. "I've got a problem."

"What is it? We're engaging a Tholian destroyer."

"One of the prisoners I saw. In the holding cell. He was your—"

"Stop right there!" Sven glanced around the bridge, feeling the cold sweat returning. "Harry, listen to me. I don't have time to explain. I'll do that later. Now carry out your orders!"

He hadn't meant to shout, but somehow it sounded that way, especially since the bridge was now dead silent. "Aye, Captain," van Meers replied after a long moment, putting a tell-tale emphasis on the last word.



He felt, rather than saw, the stares coming at him from all sides. Trying to ignore them, he said, "Are we on the down shield?"

No one spoke. "I said, ARE WE ON THE DOWN SHIELD?" he demanded.

"Uh, aye, Captain," Emily Pearson stammered.

"Then drop shield and commence rescue!"

#### Holding Pen 22, Tholian Mobile Base Akk-10

It was much easier this time. Van Meers knew the correct coordinates and had the team beamed directly into the cell.

He had briefly considered refusing to take his Prime Team back to the Tholian base, but any such refusal would, in the midst of battle, have been considered an act of mutiny. For such a thing, he could have been court-martialed just as he was certain Captain Fregessan would shortly be.

The beam-in must have come as a surprise to the two Tholians who had been in the cell during the first attack. One of them was settled on the floor near the half-open door, trying to get it fixed so that they could exit the chamber. The other was helping, but by the time he had turned his huge bulk to confront the Redoubtables, he was already stunned. His comrade followed shortly thereafter.

Van Meers turned to the group of prisoners, several of whom were clustered around a fallen figure. "Get us out quickly," one of them implored, pointing at the obviously injured man. "One of the Tholians knocked him into the wall during the fighting."

Harry looked at the speaker, who was tall, wiry, fair-skinned, and covered from head to toe with freckles. His blond hair was long, almost to his shoulders, and he wore a half-shaven beard. But there was no mistaking the resemblance to Captain Fregessan.

"Come with me," he said. "I think there's someone who wants to see you."

#### Bridge, Federation CA *Ramilles*

"Fire's under control, sir," said Bowen, waving away smoke with one hand. The extinguishing foam had cooled his weapons console, but it looked unusable. The damage had come from the base's remaining phasers, including one that had been hastily repaired, all of which had fired moments ago when the *Ramilles* dropped her aft port shield to conduct the rescue raids.

"Very well. Patch weapons through to my panel," ordered Fregessan.

There was an obvious murmur at this. Sven could tell they all knew something was wrong, but no one chose that moment to risk mutiny. "Done, Captain."

"Report from the Prime Team coming in," said Blankenship. "Rescues successful. Repeat, rescues successful!"

"Then we have no reason to stay here. Set course for the Federation border."

"Sir, the Tholian destroyer is angling to intercept. And sensors are now picking up another new entry—another patrol type—no, it's a destroyer."

"Earl, send to commander, Tholian destroyer—"

"Sir?"

"You heard me, mister! Send this: 'We are departing the area. If you do not wish to be destroyed, heave to immediately.'"

There was no response for a moment. Then, finally, on the screen they saw the destroyer change course slightly. "He's paralleling us, Captain!"

"To make sure we're honest about it.

"Very well. Increase speed to warp 3.04. Drop active fire control to prove we're serious, and discharge the photons as soon as full speed is achieved."

"Aye-aye, sir."

The destroyer slowly fell back as the *Ramilles* accelerated. In another few moments they were at disengagement speeds, and Fregessan rose from his chair, taking one last gaze around the bridge, for what would surely be the last time as the ship's captain.

"Captain?" said Bowen, his voice cracking slightly.

"Yes, Lieutenant?"

"Uh ... congratulations on a great mission, sir."

"Thank you. And thank you all for your dedication. Now, I think there's someone waiting to talk to me who I haven't seen in years."

So saying, he moved towards the exit. He paused there, remembering two pieces of unfinished business. How strange, he thought, that these would be the last orders he would give. "Two final things," he said with a sigh. "First, send a medical team to the briefing room to check on Commander Rochelle."

This was greeted by surprised stares, but Blankenship nodded assent. "Aye, Captain."

"Second, send a security team to the sickbay."

"What?" Blankenship looked at him. "Why a security team, sir?"

"Why, to arrest me, of course," Fregessan answered as he strode into the turbolift.

#### Klingon Border Station #6, Y166

The two Slirdarians were out of handcuffs for only about a minute. The Federation police ship's Marine officer unlocked the ones they had worn for the voyage across the Neutral Zone and waved them through the hatch. The Klingon ESS officer had other, less comfortable handcuffs on them before they cleared the base's airlock.

"Stupid apes," the Marine snarled under his breath. "They should have stayed in the Federation. Not much of a homecoming after three years in a Tholian prison. Damned Klingons."

#### Courtroom #4, Star Fleet Headquarters Y167

"Captain Fregessan," the military trial judge pronounced, "having entered a confession and waived all options for defense, you are hereby found guilty of the crime of barratry, which is defined in Star Fleet Regulation 304.51 as the fraudulent breach of duty on the part of a ship's master to the injury of the Federation. The Federation cannot in any way condone such activities by any member of the Star Fleet, no matter what the perceived justification. You are also found guilty of the charges of reckless endangerment of Federation personnel, falsification of official orders, dereliction of duty, and the violation of neutral territory without authorization in breach of Standing Order #4. You are reduced in rank to crewman 3rd class, with forfeiture of all pay and allowances. You are further sentenced to pay a fine of 10,000 Federation credits and to serve 10 years at hard labor performing humanitarian tasks at such locations as the Federation Department of Corrections shall consider appropriate. The court calls your attention to the fact that it has been lenient in the penalties assessed due to the extenuating factors involved, those being the rescue of Federation and other personnel and the fact that there was no loss of life. Have you anything to say?"

"No, Your Honor, I do not." Fregessan was led away. ★★★



## UNIVERSE NOTES

### MILITARY RANKS IN THE GORN HEGEMONY

The Gorns combine their rank and branch insignia into a single elliptical device. The branch insignia forms the background: a diamond for starship operations crews, an eight-pointed star for engineering, a circle for science and medical, a narrow triangle (point up) for fighter pilots, an equilateral triangle (point down) for ground troops, and smaller versions of the starship insignia for PF crews.

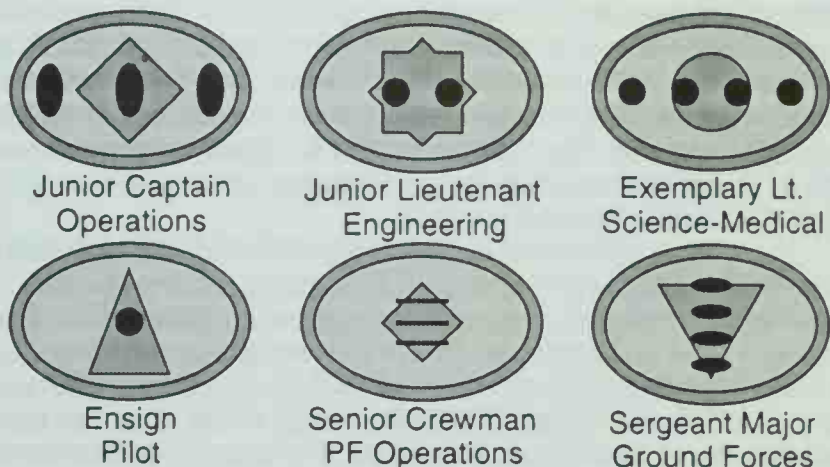

Military ranks come in groups of four. The lowest are the crewman, ranked as Recruit, Junior Crewman, Senior Crewman, and Exemplary Crewman (denoted by thin horizontal lines). The second group are the non-commissioned officers, all of whom (in the Navy and Ground forces) use the ranks of Corporal, Junior Sergeant, Senior Sergeant, and Sergeant Major (denoted by horizontal ellipses). The junior officers include Ensign, Junior Lieutenant, Senior Lieutenant, and Exemplary Lieutenant (denoted by round disks or dots). Command grade officers include Junior Commander, Senior Commander, Junior Captain, and Senior Captain (denoted by large vertical ellipses).

Admirals include Commodore, Rear Admiral, Vice Admiral, and Fleet Admiral. Admirals have no branch insignia and are denoted by very large dark dots. The insignia of a Vice Admiral is shown.—SVC

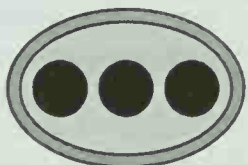

### LDR UNIFORMS

The uniform of the LDR Defense Command is essentially a combination of the Lyran Naval uniform and the plain smock worn during the period of the Democratic Dark Star County. The shirt is mustard yellow with a red ring collar and a red diagonal stripe extending from the center of the neck to the right hip. The collar and the stripe are trimmed in black. A single epaulette is on the left shoulder. The epaulette displays the rank insignia, but is covered by a piece of black cloth. The black cloth is removed for dress occasions, but during normal duty it is theoretically impossible to tell a petty officer from an admiral. This is a throwback to the 'equal' military. The left sleeve carries the LDR emblem, and medals and badges are worn over the left breast. (See pages 23 and 25 of Module C3.)

The uniform looks the way it does because one of the heroes of the Vandha campaign was wounded in close combat with a noble of Duke Larzhak's house. The right side of the hero's shirt was slashed away by the enemy's knife, wounding him from the neck to the waist. After killing the enemy, the hero went immediately into space combat with his wounded right side exposed. Today this is reflected in the red diagonal stripe and the fact that there are no insignia or accouterments on the right side of the uniform. The hero in question was then ship Captain Kiroth.—Jon Cleaves

★★★

### WARP SPEED!

Star Fleet Battles bases its warp factors on the original data which defines the warp factor as the cube-root of the speed of light. Thus, speed 8 is eight times the speed of light and warp 2. For the convenience of fiction writers (and readers), here is a handy translation table.

SFB SPEED	WARP SPEED	FICTION USE
1	1.0000	1
2	1.2599	1.2
3	1.4422	1.4
4	1.5874	1.6
5	1.7099	1.7
6	1.8171	1.8
7	1.9129	1.9
8	2.0000	2
9	2.0801	2.1
10	2.1544	2.15
11	2.2240	2.2
12	2.2894	2.3
13	2.3513	2.35
14	2.4101	2.4
15	2.4662	2.46
16	2.5198	2.5
17	2.5713	2.57
18	2.6207	2.6
19	2.6684	2.67
20	2.7144	2.7
21	2.7589	2.76
22	2.8020	2.8
23	2.8439	2.85
24	2.8845	2.88
25	2.9240	2.92
26	2.9626	2.96
27	3.0000	3
28	3.0366	3.04
29	3.0723	3.07
30	3.1072	3.1
31	3.1414	3.14
32	3.1748	3.2
64	4.0000	4
125	5.0000	5
216	6.0000	6
343	7.0000	7
512	8.0000	8
729	9.0000	9

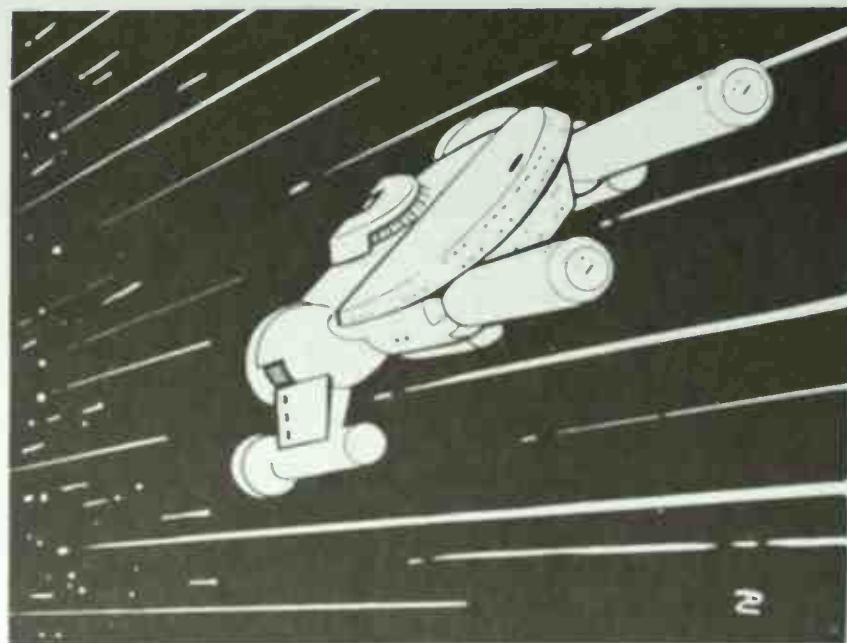



## STAR FLEET COMMUNICATIONS CENTER

### STARLETTER TO BECOME *STAR FLEET TIMES*

Starletter, the official Star Fleet Universe newsletter for many years, will come to an end in Nov 94 with issue #92. It will be replaced with an entirely new newsletter, *Star Fleet Times*, beginning in January 1995. *Star Fleet Times* will appear 10 times per year (skipping June and December) and will include 12 pages. It will have everything that Starletter had (new ships, scenarios, and rules; convention announcements; product schedules; etc. provided by ADB) plus articles on tactics, gaming groups, conventions, fiction, and more.

*Star Fleet Times* is being edited by Bruce Graw of Agents of Gaming under a special contract and will have extensive editorial independence and will have a sort of "wild west, shoot from the lip" flavor. Things that would *never* get printed in other Star Fleet products will be right at home in *Star Fleet Times*, so long as they are well done and FUN! Bruce is already planning VERY special issues with new ships for April and October.

All Starletter subscriptions will be automatically converted to *Star Fleet Times* subscriptions. You will get one issue of *Star Fleet Times* for every issue of Starletter you have coming. This will get you three times as much for your money, although your subscription will run out a little faster since *Star Fleet Times* will appear nearly twice as often. However, you'll be having so much fun that you won't mind!

Those who want new subscriptions can send \$15 per year (US, APO, FPO) to Agents of Gaming, P.O. Box 31571, Dayton OH 45437. Canadians must send \$16 (in US funds); airmail overseas subscriptions are \$22 per year. Players in Europe should deal directly with Agents of Gaming, not through Task Force Games U.K.

TFG reports that the stock of back issues of Starletter is rapidly approaching zero, and none will be reprinted. This is your LAST chance to complete your collection of these historic final issues of wargaming's best newsletter. Issues are \$2 each, including postage. Available issues include: #80 Gorn Fast Carrier Resupply Ship, #81 F&E Battleships, #84 Old Galaxy Raider, #84 Klingon Early Years F4, #86 Tholian CW-carrier, #87 Federation commando frigate; #88 Lyran DW-carrier, #89 Frax submarine, and #90 Jindarian Destroyer.

SubSpace News, a four-page "playtest section" of new material, will not be continued, but material that was prepared for future issues will be released in *Star Fleet Times*. Back issues #2 (Frax submarines), #3 (the new Flivver race), and #4 (Alliance war cruiser maulers) are available for a very limited time from TFG for \$2 each (including postage). Stocks of all three issues are very low; none will be reprinted.

### PRIME TIME MERGED INTO *PRIME ADVENTURES*

Prime Time, the official Prime Directive newsletter, is being merged into the new Prime Adventures magazine. Prime Time #6 will be the final issue and will have instructions on how to obtain a refund or credit. Back issues are going very fast (\$2 each) and will not be reprinted.

### JOIN "THE STAFF OF THE STAFF"

The Star Fleet Senior staff need the help of local gamers in their areas to help test new ships, rules, and scenarios and to develop new products. It's hard work, but you get to see (and influence) new products before they appear. We have staffers in Chicago and Naperville IL, Houston TX, St Louis MO, Cleveland and Dayton OH, Milwaukee and Madison WI, Los Angeles CA, Fort Irwin CA, Orange County CA, Colorado Springs and Denver CO, Saginaw MI, Atlanta GA, and Tacoma WA. If you want to contact a staff officer, send a letter with a stamped self-addressed envelope to ADB and we'll forward it to him.

### STAR FLEET BATTLES ON GENIE

Star Fleet Battles is active on the GENIE computer network. Star Fleet Battles is Category 10, page 805, in the Games Roundtable. Topics discuss SFB, F&E, doomsday, questions, rules changes, major projects, errata, tournaments, conventions, new ships, etc. You can send in term papers directly.

Many downloads (new SSDs, software to allow most computers to read SSD files, playtest scenarios, prototype rules, drafts of articles, lists of players by zip code, etc.) are available in the library on page 1020. (All downloads are official ADB material; non-ADB uploads are allowed only if approved in advance.) Files downloaded from GENIE remain under ADB's copyright and are not to be uploaded to other systems. If you see SFB material on other bulletin boards, advise ADB or TFG by mail with all relevant information.

Real Time Conferences with top SFB staff members are held on Tuesday nights (11pm ET) in Room 3 of page 805;2. We alternate between product development conferences hosted by Steve Cole and tactics seminars hosted by Steve Petrick.

You can send Electronic Mail to Amarillo Design Bureau care of ADB\$ and to Task Force Games at TFG\$. You can contact Agents of Gaming at B.GRAW1 and ask questions about Star Fleet Warlord in topics #39-40. Prime Directive is in topics #34-36. Federation & Empire is in Topics #19-20.

Call GENIE at 800-638-9636, and ask them for information.

If you cannot find the SFB section, send Email to ADB\$, STEVE.COLE, SFB-ASSIST, TFG, or TFG\$. Internet users should use only the ADB\$@GENIE.GEIS.COM address for ADB and the TFG\$@GENIE.GEIS.COM address for TFG.

### STAR FLEET BATTLES ON COMPUSERVE

ADB is now available on CompuServe. You can contact ADB at 71333,2123 and find messages posted in Section 11 of the Play-by-Mail Games Forum. Errata files and playtest material are in the libraries there.

CompuServe offers the usual services (Email, news, travel, research, finance, computer user support, etc.) and forums discussing everything from games to dinosaurs to politics.

To get on line, call 800-524-3388 and ask for Representative #437 for a free introductory membership.

### STAR FLEET BATTLES LEAVES AMERICA ON-LINE

After a brief experiment, official support for SFB on the America On-Line network has been terminated, and all uploads deleted. The atmosphere there was not conducive to a friendly and constructive discussion.

### TASK FORCE SPARE PARTS AND MAIL ORDER

You can order any TFG product directly from Task Force Games. You can also order extra counters, maps, and other components. Send a stamped self-addressed #10 business-size envelope (29¢ US postage) for a catalog. TFG now takes Visa, MasterCard, and Discover Card.

TERMS: Minimum order \$10 (\$20 for all overseas orders). All orders must add \$4 for postage & handling in the US. Canadians add 20% of the retail price for postage & handling (minimum: \$4.00). Overseas add 40% for surface and 60% for airmail shipping. All payments must be in US funds. All checks must be drawn on a US bank. Texas residents, please add 8.25% sales tax.

ON THE CONTINENT: European customers, please contact Task Force Games U.K., Unit 1, Annesley Farm Workshops, Weavers Lane, Annesley Park, Nottingham NG15 0AT Telephone: 0623 722550; Fax: 0623 722551. This includes orders for merchandise, spare parts, and requests for catalogs.



## TOURNAMENTS!

### HAVING A CONVENTION?

ADB publishes announcements of upcoming conventions that have SFB tournaments (in Starletter, and from Jan 95 in *Star Fleet Times*) and lists of SFB tournament winners (in Captain's Log). Send such information to ADB well in advance of the convention. We can only publish the information that we receive. Those running SFB events at conventions can obtain a Sanctioned Tournament Kit from Task Force Games for \$10. This kit includes: Instructions, Rated Ace Nomination Form, \$25 in TFG gift certificates for use as prizes, list of any recent tournament rules changes or authorized experimental rules, and the seven-page "Judge's Errata" sheet. You must include a copy of the convention program or flyer (or a letter from the convention operators) showing your event listed at a real convention.

### TOURNAMENT RULES AND SHIPS UPDATE

For your convenience, a complete set of tournament rules and SSDs was published in Module T. Here is a complete list of updated rules and ships:

The Lyran ship should have a UIM-disruptor table, but at least it is clear that it can use its UIM (once).

The Andromedan PA mine (which is now legal) only drains 15 points from a plasma torpedo. It says this one place, but we wanted to reinforce the information lest it be overlooked.

An Orion with a drone rack can swap for type-IVs. The ship is limited to one phaser-G (per package), and the special damage rule in Captain's Log #15 is no longer used.

The six new tournament ships (with the changes noted below) are currently being used in tournaments run by ADB certified judges. They will become sanctioned for ALL tournaments as of 1 January 1995.

The LDR ship in Module T is canceled in favor of the Red Jaguar. The SSD for the Red Jaguar published in Captain's Log #15 has been modified after its initial tournament performance by the addition of two APRs. It has no UIM.

The WYN Black Shark: 2 drone points; HET = 5, no EM.

The Seltorian Green Wind cruiser in Captain's Log #15 has been modified by the addition of two center warp boxes.

The Tournament King Eagle published in Module T has been modified by the addition of five armor boxes (total ten). There was no change to the TKR.

The breakdown rating of the Archeo-Tholian ship published in Captain's Log #15 has been changed to 5-6.

For (C12.364) penalties, use hull boxes, then labs.

The racetrack infield is a tournament barrier. Optionally, it is a "grass infield" you can fire across, but moving across it costs 5 movement points per hex (web movement rules).

In Assigned Target, you can hit the "markers" over more than one consecutive turn IF you draw your own ship on both turns. The "markers" should be in 2212, 1917, and 2517.

A 4-page update with replacement SSDs for the Seltorian, LDR, and King Eagle ships is available from TFG for \$2 including postage.

### TOURNAMENT SANCTIONS

A Sanctioned Tournament is one that strictly follows the rules in Module T. If the local judges make any changes to the rules, it is not a Sanctioned Tournament (and any players who attend it should notify ADB). Sanctioned events are marked as such in the tournament reports.

Rated Ace tournaments must meet additional requirements: They must be at a convention and have 16 or more players. The winner must be picked by three rounds of single elimination, and the judge must fill out a simple form and send it to ADB with a convention program.

### ADB CERTIFIED JUDGES

The current ADB-Certified tournament judges, by seniority:

1. Chief Justice Frank Crull (SFB, F&E, SFM).
2. Tournament Marshal Steven P Petrick (SFB, F&E, SFM).
3. Senior Judge John Berg (SFB).
4. Senior Judge Jeff Laikind (F&E, SFB).
5. Judge Keith Velleux (SFB).
6. Judge Scot McConnachie (SFB, F&E).
7. Judge Tony Zbaraschuk (SFB, F&E).
8. Judge Bruce Graw (SFB, SF Warlord).
9. Judge Mike Filsinger (SFB).
10. Judge Marc Spencer Cocherl (SFB)
11. Judge Tom Gondolfi (SFB)
12. Judge Ken Burnside (SFB).
13. Judge Joseph Butler (SFB).

You do not have to be a Certified Judge to run SFB events.

### BATTLE REPORTS

SFB Tournament winners at conventions since CL#15:

★ STELLARCON 18, 4-6 March 94, High Point, NC, Sanctioned, 1st C.J. Lamb (Lyran), 2nd Dave Long; Judges: Bill Mann, Joseph Martin, and Thomas Milligan.

★ MADISON GAMES CON, 14-15 May 94, Madison, WI, Sanctioned, 1st Dane Jespersen (Andromedan), 2nd David Sutton (Tholian), 3rd Ken Rotar (Federation) and Robert Banks (Klingon); Certified Judge Jeff Laikind.

★ WAR! ZONE, 2-4 Apr 93, Alamonte Springs, FL, Sanctioned, 1st David Bostwick (Kzinti), 2nd Rob Wilkes (Romulan), 3rd Steve Dickson (Klingon) and Don Haynes (Gorn); Judge Frank DiVincenzo. There was also a Circle scenario, which was won by Matt Towns.

★ GAMEX 94, 28 May 94, Los Angeles, CA, Sanctioned, 1st Jason Singleton (Kzinti), 2nd Paul Scott (Orion), 3rd Hohn Cho (Orion) and Frank Gilson (ISC); Judge Victor Ippolito.

★ COGCON I, 22-24 April 94, Rolla, MO, Sanctioned, 1st Jeff Bolhassan (Federation), 2nd Devin Durham (Federation) and Brian Knowles (Gorn); Judges William A. Davies, Shanna Davies.

★ HEXACON IV, 17-19 Jun 94, Mesa, AZ, Sanctioned, 1st Jonas Johnson (Kzinti), 2nd Mike Rodriguez (ISC), 3rd Vince Weibert (Tholian) and Rick Masci (Lyran); Judges Ken Burnside, Rich Sherman, and Steve Sims.

★ EURO-GENCON, 12-15 May 94, England, Sanctioned, Captain's Tournament; 1st Jonathan Crowe (Romulan), 2nd Maj Farsi (Gorn). Patrol Tournament; 1st Paul Stovell (Hydran), 2nd Justin Owen (Hydran). Judge Andrew Smith.

★ ST JOSEPHS VALLEY GAMERS CONVENTION, 17-18 Jun 94, South Bend, IN, Sanctioned, 1st Paul Pundy (WYN), 2nd Alex Pundy (Lyran), 3rd Dr. Andrew Pundy (WYN) and Jason Polzin (WYN); Judge Joseph Butler.

★ ORIGINS: See special report on next page.

★ DRAGONCON 94, 17 Jul 94, Atlanta, GA, Sanctioned, 1st Michael Gastright (Andromedan), 2nd Mike Mitchell (Kzinti), 3rd Chris Williams (Federation) and Chuck Carroll (Federation); Judge Warren E. Taylor.

★ DEXCON 3, 22 Jul 94, Newark, NJ, Sanctioned, 1st Edward Slusarek (Romulan), 2nd Bill Schoeller (Tholian), 3rd Kevin Block-Schwenk (Andromedan) and Robert Estrada (Gorn); Judge Stephen McCann.

★ GENCON 94, 18-21 Aug 94, Milwaukee, WI, Sanctioned, see special report on page 14.

★ MICROCON IV, 12-14 Aug 94, Houston, TX, Sanctioned, 1st Terry Haugh (Orion), 2nd Curtis Wood (Orion), 3rd Paul Hamilton (Orion) and Matt Burleigh (Klingon); Judge Frank Crull.

★ DALCON 2, 20-21 Aug 94, Halifax, Nova Scotia, Canada, Sanctioned, 1st Perry Kurzynski (Andromedan), 2nd Chris Levy (Orion: A photon, hellbore, hellbore, phaser-1, phaser-1; B



photon, hellbore, hellbore, drone rack, drone rack), 3rd Stephane Colin (Tholian); Judge Sean Dzafovic.

★ DRAGONFLIGHT 94, 26-27 Aug 94, Seattle, WA, Sanctioned, 1st Drew Malidore (Kzinti), 2nd Robert Fautenberry (Tholian), 3rd Daniel Bennett (Gorn) and Geof Clark (Romulan); Judges Scot McConnachie and Tony Zbaraschuk.

★ TEXICON 94, 2-5 Sep 94, Houston, TX, Sanctioned, 1st Mark Gratkowski (ISC), 2nd Paul Kramer (Klingon), 3rd Jim Doherty (Federation) and Jase Philip (WYN); Judge Terry Haugh.

★ TACTICON 94, 16-18 Sep 94, Lakewood, CO, Sanctioned, 1st Theodore Fay (Kzinti), 2nd Chuck Strong (Orion: A 2x FB, 2x pl-F, 1x ph-G; B 1x ph-G, 4x ph-1), 3rd Dan Hoffacker (Kzinti) and Andy Bortz (Gorn); Judge Scott Moellmer won a commendation for outstanding tournament reports.

★ ANDCON, 15-18 Sep 94, Independence, OH, Sanctioned, 1st Mark Loughman (Romulan), 2nd Steve Koehler (Gorn), 3rd Andrew Lint (Kzinti) and Kurt Kopp (Klingon); Judge Sean Grubb.

Reports on the winners at SFB tournaments must include: Convention name, date(s), format (sanction, ships used, rules, structure, etc.), top four finishers (and the ship that they flew), judge(s), any special information, any other Star Fleet events and their results, any special cases or situations, etc. Tournament winners are published in Captain's Log; Tournament announcements are published in *Star Fleet Times*. While we expect reports to be sent promptly, we will process valid reports whenever we receive them. The primary goal is to see that the winners and judges receive the recognition they have earned.

Rated Ace nominations must include CLEAR and readable addresses (no abbreviations) for the players and a copy of the program, or they will be sent back to the judge for completion.

If your tournament was not reported here, send a report to Amarillo Design Bureau for inclusion in Captain's Log #17.

**ORIGINS 94: THE FEDERATION STRIKES BACK**

Origins 1994 in San Jose, California, was good for the players and bad for the dealers. Total attendance was just over 4,200, including dealers, gamemasters, guests, and so forth, far less than expected (or needed). For the gamers this was great since the dealer room was uncrowded (and dealers had plenty of time to chit chat about the games) while it was bad for the dealers, almost all of whom lost thousands of dollars. Coming on the heels of the disappointing show in Fort Worth, this resulted in a lot of doom and gloom. Presumably, the show next year (in Philadelphia) will be much better, as shows on the East Coast have always been better attended. Origins is to remain in Philadelphia for at least three years, and perhaps permanently. While there have been rumors of splitting the show after 1997, holding events on both coasts, the dealers have made it very clear that they are not interested in paying two sets of show expenses for one set of sales, so don't hold your breath for another California Origins in your lifetime.

Most of the tournaments were underpopulated, which was good for gamers since they could generally get into any game they wanted to at the last minute. Magic the Gathering expected "several hundred" players and got 130 (about what would have been expected for a regional convention). Battletech expected 250 and got 50. Star Fleet Battles did much better than most (selling 141 tickets for Captains). Even if this was not as many as the 200+ at Milwaukee 92 and Fort Worth 93, it was more than the years from 1984-1991. The other Star Fleet Universe tournaments (and all five Prime Directive events) were full as well. Andon (the convention management company) laid the credit for the success of SFB at the feet of ADB and Task Force Games, which heavily promoted Origins through their products during the year. (This led ADB President Steve Cole to ponder

out loud: "Why doesn't EVERY company include Origins promos in EVERY product? It costs nothing to the company and would ensure a better attendance for everyone at the next convention.")

The ADB crew of judges was highly praised by TFG, convention management, and the players as clearly the best organized and most professional tournament operators at the entire convention. Andon announced that in recognition of this professionalism, ADB would have the EXCLUSIVE right to run SFB events at Origins (other than small one-round events for up to eight players approved in advance by ADB) for all time. So any rumors (like those last year) about some unknown bunch coming in and running major SFB events with huge prizes can be ignored before they start.

The Fleet Captain's event was won by Bill Schoeller in a Federation CA in a devastating 7-hour 25-turn slugfest in which he successfully did two HETs. Second place went to Paul Kramer in a Romulan Firehawk; Paul said he would fly a Klingon next year and was confident of Victory at Philadelphia. Third place went to Geoff Clark and last year's champion, Hohn Cho. Fifth place was shared by Paul Pundy, Brad Hinkle, Dr Andrew Pundy, and Dan Bennett. Also winning ace status were Bob Kreis, Gregg Dieckhaus, Norman Cruz, Paul Scott, Andrew Cook, Perry Carlson, and Chris Mazza. Every race made it into the finals (except for the ISC and Tholians, who made it into the Patrol finals).

Patrol was won by Federation Ace Jerome Bambrick in a stunning victory over WYN Captain-General Alex Pundy. Third place went to previous aces Steve Kay and Alex Vaeth. Also winning ace status were Patrick Stapleton, Chris Larsen, Allen Phelps, and Richard Eitzen. Other finalists included Elizabeth Weibert (the first lady to make it into any SFB finals), Vince Weibert, Perry Carlson, Phil Torres, Jeremy Williams, Mark Gratkowski, Steve McCann, and Ron Dodd.

Saturday Patrol resulted in a tie between Federation aces Vince Weibert and Steve Huntsberry; they elected not to play off (since the Federation never has civil wars).

In the F&E Tournament, Joe Stevenson took Best Overall while Tim Carroll was Best Klingon player and Wil Culbertson was Best Federation player.

The convention had scheduled a squadron battle tourney, but the judge for it (not an ADB judge) never showed up. ADB offered to provide those who had signed up for the event with enough SSDs and a complete set of Jindarian rules, and they played the very first fleet battle against Jindarians.

Due to contact problems between the convention and hotel, the SFB events were (for the first time in years) forced to move around, holding two days at the Holiday Inn and one day in the convention center itself. Only the personal intervention of Steve Cole in dealing with the hotel staff and managers (after Andon had given up trying to straighten out the contracts signed before they came on board) made things work as well as they did. Thanks to Steve, the hotel allowed us to play late on Thursday and Friday and allowed the Vampyre Central game (a live-action RPG not related to ADB and SFB) to avoid being shut down. Andon said that in future these problems would not recur as it would be in on writing the contracts from the start. The Holiday Inn staff was always courteous to ADB and provided us with everything we asked for and more.

Module X1 was a major hit, and CL#15 sold strongly. Despite the anti-RPG reputation of Origins in general, the Prime Directive module Uprising made a powerful impact. TFG also had prototype copies of the new miniatures, and completely sold out the available supply. They had a new D7 and Fed CA (in two scales, 3" long and 1" long) as well as a new Romulan Firehawk and B10V. Also available were several of the old Starline 2200 ships which have been put back into production.



**GENCON 94: THE KZINTI REASSERTION**

GenCon 94 was, like all GenCons, crowded and noisy and a barrel of fun. TSR had promised us a better tournament facility this year, and it was better than the old hallway in the main building, but it was not half big enough, and the overflow space (in another hallway) was too dim for gaming after sundown. They have promised to give us yet another (better) facility next year, and we're currently negotiating for space.

Bill Albert won the Captain-General Tournament in the Kzinti (which always seems to win at GenCon). Second place was Paul Scott in a Romulan. Third place went to Paul Pundy and his brother Alex Pundy, both flying WYN auxiliary cruisers with two hellbores, a phaser-G, and a disruptor.

The Patrol Tournament was won by Nathan Bangs in an Andromedan, who handed defeat (and second place) to Kerry Mullan (flying a WYN AuxBC with a plasma-F, two phaser-Gs, and a type-B drone rack). Third place was shared by Klingon David Beeson and WYN Gary Langtimm. (Gary flew a WYN AuxBC with a hellbore, a photon, a disruptor, and an ADD-12!)

Four players had the best records in Saturday Patrol, so they paired off in the finals on Sunday morning. Federation ace Jeremy Williams and Lyran ace John Hilgers triumphed over Andromedan Ron Mulder and LDR renegade Barry Stephens.

Paul Kondon won Best Overall in the Federation & Empire Tournament. David Coulthurst won the honors as Best Fed while Jay Paulson was named as the Best Klingon.

Stephen V. Cole highly praised his staff of veteran judges, who were able to run the events with minimal supervision, allowing him to spend time talking to the convention officials about various problems with the facilities provided (which, again, were too dark to play in), talk to other game companies and industry leaders, and meet individually with dozens of SFB players regarding their questions, proposals, concerns, hopes, and dreams. The judging staff included Steven P. Petrick, Senior judges John D. Berg and Jeff Laikind, and Certified Judge Mike Filsinger. Assistant Judges included Ken Burnside, Joseph Butler, and Grant Meixel. There were many compliments to the best-run event at GenCon.

Several non-ADB events were run. GenCon was courteous enough to have ADB approve each in advance, and all were scheduled into the ADB area so that they could draw on the players present for the main tournaments.

Daryl Millard ran a beginner scenario entitled *NO PEACE* which attracted two groups of players. The scenario involved a base station defended by a Federation CA, Gorn CA, and Kzinti CS from attacks by two D7s and two KR's. In the first battle, the Klingons moved in on the base station but were repelled by the phaser-4s. The Romulans then appeared and obliterated the base as the Klingons disengaged. There was minimal damage to the Gorn, Kzinti, and Fed ships. In the second battle, the Klingons sidestepped the base station, but one of their ships was vaporized in a close-in fight with a Kzinti CS. The base station was damaged but survived due to the help of the Gorn and Federation cruisers.

Chris Kenth ran a CW-squadron battle scenario named *Eat Static* which attracted several teams.

Agents of Gaming ran three playtest sessions for the new *Star Fleet Warlord Boardgame* (with three different sets of draft rules to test different ideas). The gang from AoG also ran two major scenarios with a huge map and miniatures. On Thursday, they ran *Giants Among Men*, a scenario with two battleships and a dozen heavy battlecruisers. John Scott emerged victorious from this struggle. On Friday, 14 players went into the Maze of Asteroids, and Darrell Brown was the winner.

David Piech ran two scenarios (on a huge table with oversized maps and miniatures). WYN Commodore Scott Warner flew a pair of Raider Cruisers to victory at Mad Jack's Hole,

edging out Honest Abdul himself. The Hydran Home Fleet led by Dave Earlywine successfully stopped the Klingon Western Fleet (led by a B10) before it could wreck the newly-liberated Hydran homeworld. Losses in the battle included 25 Stingers, two D7s, an F5E, and a Lyran CW. The Hydrans took no other internal damage.

Three cadet games were run to train new players.

Mark Costello ran the first official Prime Directive National Championships. Cliff Yahnke ran several Prime Directive demos in the dealer area.

**TWO LITTLE PHASER-3s or****WHAT'S REALLY GOING ON WITH THE ORION TC?**

There has been a lot of confusion about the Orion TC and the two sets of changes to it, and it's about time that we got all of the information out to the public.

The first thing to understand is that when ADB adjusts tournament ships, we do so based on their TOTAL record, of all games played (that we can get stats for; many local events provide them, many do not) not just their record of winning tournaments. Several people have tried to statistically analyze the victory reports in Captain's Log, but without access to the total records, such analyses are incomplete. Certainly, the Romulan, WYN, and Kzinti have won many events, but the total number of GAMES they have won is well within the 40-60% range that we consider acceptable. While the Orion hasn't won a whole lot of events, it came to our attention (and came to be changed) when it won more than 70% of its GAMES.

Way back when, the Orion TC was a power-house and had the best record. A set of adjustments pushed it down below the 40% win rate, and we added the forward-firing wing phaser-3s to pad the phaser-1s. A year or so went by, and its victory record was hovering just above 50% and all was fine. THEN someone invented the "phaser boat" (i.e., the all-phaser Orion). This reached victory percentages over 70%. When all of the options were filled with gatlings and phaser-1s, the damage priority rule came into play and the phaser-1s were suddenly padding the phaser-Gs, and an Orion that had taken internal damage was suddenly retaining VERY high percentages of its damage-producing ability, higher than ANY other ship. If you analyze the win ratings (of all games) for the Orion after the wing phaser-3s were added, you don't see a problem, but when you break this down into before and after the advent of the phaser boat, you see a major problem with the Orion winning too often. (This didn't apply to the superficially similar WYN because it has some non-phaser weapons fixed in the design and, hence, loses its firepower at the prescribed rate.)

When we found the problem, the obvious solution was to limit it to one gatling. The Orion players, however, lobbied to keep the second gatling. They would, they said, accept just about ANYTHING if they could keep gat #2. Against my better judgment, and overruling a majority vote of players (and separate votes of judges and aces, ALL of which were 2-1 in favor of the "one gat" rule), I allowed myself to be talked into the funky damage rule (which no one understood). At Origins, some Orions complained that the rules changes were not fair, but it had won 71% of its games. Once that fact got out, players who had lost to Orions were demanding to be put into a special extra round of the finals, something that wasn't possible or practical. While the "victims of Orion" were mollified that they had seen the ship in advance and could have picked it, we obviously had to FIX the Orion before GenCon, or throw it out of the tournament, or throw out all of the other ships. We limited it to one Gatling, and it won 57% of its games in Captains (4 of the 16 finalists), and 54% overall. Obviously, we did the right thing. We just didn't do it soon enough. ☺☺☺



**RATED ACES**

Rated Aces are players who have reached the finals of the National Fleet Captain's and Patrol Tournaments and those who have won certain sanctioned regional tournaments.

Rated Aces get their names in the next Captain's Log, a handy ID Card, and a Rated Ace patch (Origins 91 and later only) and aren't required to play other Rated Aces at the next Origins until the finals (or until there isn't anyone else available).

If you are eligible for a Rated Ace card and didn't get it, send a stamped self-addressed envelope to ADB to receive it.

If you feel you won a Rated Ace card but are not listed, it is possible that we never received the paperwork from the convention. Contact ADB to determine the status of unlisted conventions. If you are responsible for sending in the nomination from a convention, please send it promptly, but even if it is late, we'll process it. There is nothing worse than not sending it at all.

If you are running an SFB event at a convention, send a stamped self-addressed envelope to Task Force Games (or ADB) and ask for an official Rated Ace Nomination Form. You MUST have this form to secure a Rated Ace ranking for the winner of your tournament. All requirements are specified on the form (which refers you to the Module T for some specifics). It is virtually impossible to secure a Rated Ace ranking unless you have the nomination form *prior to the event* and **FILL IT OUT COMPLETELY**. The form requires signatures of convention officials and a copy of the program, among other requirements. Judges are responsible for ensuring that every player in the event provides a complete and legible address, whether there are 6 or 60 players.

If you win a tournament at a convention, protect your interests by getting the judge's name, address, and phone number before you leave. (The judge should be sure to get the same data for at least one convention official.) Take home a copy of the program and, if possible, a copy of the nomination form, in case it gets lost in the mail. We can't accept a nomination without the signatures, names and addresses, and a program.

Note that we process Rated Ace nominations in batches (because it is more efficient), so the wait for your card could be a few weeks, more during the pre-Origins scramble (which this year extended through GenCon and the recovery period from the cold everyone caught). We're sorry for any inconvenience.

**RECENT TOURNAMENTS**

Warzone (2-4 April 1993): David Bostwick.

CogCon I (22-24 April 1994): Jeff Bolhassan.

Guild Con II (23-24 April): Michael Gastright.

EuroGenCon (12-15 May): Jonathan Crowe.

Madison Games Con (14-15 May): Dane Jespersion.

Gamex 94 (28 May): Jason Singleton.

St Joseph's Valley (17-18 June): Paul Pundy.

Hexacon IV (17-19 June): Jonas Johnson.

Origins (7-10 July): Bill Schoeller, Paul Kramer, Geoff Clark, Hohn Cho, Paul Pundy, Brad Hinkle, Dr Andrew Pundy, and Dan Bennett, Bob Kreis, Gregg Dieckhaus, Norman Cruz, Paul Scott, Andrew Cook, Perry Carlson, Chris Mazza, Jerome, Alex Pundy, Steve Kay, Alex Vaeth, Patrick Stapleton, Chris Larsen, Allen Phelps, Richard Eitzen, Vince Weibert, Steve Huntsberry.

Dragoncon 94 (17 July): Michael Gastright, Mike Mitchell.

Micro-Con IV (12-14 Aug): Terry Haugh.

GenCon (18-21 Aug): Bill Albert, Paul Scott, Paul Pundy, Alex Pundy, Nathan Bangs, Kerry Mullan, Jeremy Williams, John Hilgers.

Dragonflight (26-28 Aug): Drew Malidor.

Texicon 94 (2-5 Sept): Mark Gratkowski.

Andcon 94 (15-18 Sept): Mark Loughman.

Tacticon 94 (17 Sept): Theodore Fay.



**STAR FLEET SERVICE AWARDS**

These awards are given to those who make significant contributions to the preparation of new products. The awards are provided on a small sticker suitable for decorating your rulebook. Those below who have not received their awards may send a stamped self-addressed envelope to ADB for them.

**◆◆◆ OUTSTANDING SERVICE AWARD**

CAPTAIN'S LOG #15, X1, F1: Tony Zbaraschuk.

FEDERATION SOURCEBOOK: John Berg, Cliff Yahnke.

UPRISING: Douglas Forsyth.

**◆◆◆ SUPERIOR SERVICE AWARD**

CAPTAIN'S LOG #15: Ray Olesen.

MODULE X1: Bruce Graw, Ken Burnside, Jeff Laikind.

MODULE F1: Jon Cleaves, Ken Burnside.

UPRISING: John Berg.

**◆◆◆ MERITORIOUS SERVICE AWARD**

CAPTAIN'S LOG #15: John Berg, Ken Burnside, Jon Cleaves, Spencer Cocherl, Frank Crull, Gregg Dieckhaus, Mike Filsinger, Bruce Graw, Jeff Laikind, Scott Mercer, Scott Moellmer, Chuck Strong, Keith Velleux, Cliff Yahnke.

MODULE X1: Mike Filsinger, John Berg, Frank Crull, Spence Cocherl, Keith Velleux, Scott Mercer, Cliff Yahnke, Jon Cleaves, James Chrysler.

MODULE F1: Frank Crull, James Chrysler, John Berg.

FEDERATION SOURCEBOOK: Jon Cleaves.

UPRISING: Reece Watkins, Cliff Yahnke, Jon Cleaves.

**◆◆◆ GENERAL SERVICE AWARD**

CAPTAIN'S LOG #15: Gary Plana, Reece Watkins.

MODULE X1: Gregg Dieckhaus, J Zellerkraut, J Bradley, A Cookson, M S Walters, M Vinarcik, J Guthridge, S Moellmer.

MODULE F1: Gregg Dieckhaus, Cliff Yahnke.



**LOST MAIL: SEND AN SASE TO ADB FOR YOUR STUFF!**

Mike Aprahamian, Stephen Armstrong, James Asher, Dan Baldwin, John Bartoli, Graeme Bayless, James Beggs, Bill Blakely, Barton Bolmen, Dave Bonham, David Bostwick, Chris Bowden, David Buschke, James Butler, Steve Butler, William Carpenito, Tim Carroll, Tom Chartoff, Sebastian Chedol, David Cheever, Neil Chochrek, James Chou, Cole Cioran, Richard Citti, Al Clarke, Jay Clendenny, Ken Cole, Steve Cooke, Gary Cope, John Cord, Robert Cowan, Graeme Cree, Wil Culbertson, Kenneth Daly, Mike Davey, Jim Davies, Michael D'Auben, Christopher Dearlove, Jeff DeBraal, Andrew Dederer, Kevin Dietl, Tony DelAguila, T Dellett, Alan DeSalvio, Kelly Donahue, Earl Durboraw, Marc Elwinger, Robert Eng, Greg Ernest, David Everett, Stephan Fassmann, Ted Fay, Troy Feikert, Joseph Felton, Jay Fisher, Dan French, Kurt Ganyo, Drew Gardner, Bill Gary, Michael Gastright, Michael Geiser, Bob Genso, Robert Giacolono, Frank Gilson, Alan Gopin, David Goswick, M Grafton, James Gronosky, Bill Guiher, Felix Hack, Troy Hammerman, Tom Hammond, Matthew Hargraves, Jim Hart, Kevin Hart, Joseph Hatfield, Stephen Hill, Fred Hood, David Hopkins, Eric Huber, Jesus Huerta, William Hughes, Charles Hunt, David Jensen, Matthew Johns, C T Johnson, Eric Johnson, Ken Kaufman, Steve Kay, Ken Kazinski, Scott Kenny, Richard Kerr, Paul Kondon, James Kundert, Phillip LaBarge, Thomas Lallier, Robert Larulippe, Brad Lee, Derek Lee, Ryland Leyton, Erik Lund, Damon McCafferty, Mark McDonald, Kevin McDonnell, TimMcGillivary, Alex Matthews, Sean Mattingly, John Meyers, Tony Medici, Mike Mitchell, Jim Moran, Mark Morgan, Albert Munson, Warren Okuma, Jeffrey Orsini, Frank Otto, Andrew Patterson, A Paulina, John Peterson, Rick Peterson, Rick Phelps, TimRay, Rodney Reineke, Dennis Ricketts, Josef Ricketts, Tony Robinson, Keith Rogers, Paul Rossi, Steve Rossi, Steve Rushing, Nathan Schattman, Mark Schultz, J D Schuster, Michael Secorsky, Eric Sims, Steve Sims, Jefferson Davis Smith, Rusty Smith, Andrew Soule, Josh Spencer, Patrick States, Jim Straetker, Anthony Steensgaard, Joe Stevenson, Michael Stiles, John Stone, Paul Stovell, Paul Susac, David Sutherland, Mike Thompson, Michael Toler, Sean Upchurch, Mike Vinarcik, Koen van der Pasch, J Wagner, M Scott Walters, Dave Washburn, Dave Weidner, JimWeisser, Mike West, Matt Westmoreland, Shayne, Weyker, Jeff White, Jeffrey Wong, Mark Yaeger, Chris Young, David Zimdars, Simon P Zwart.





## BUILDING A BETTER LOG

We continue receiving many comments on Captain's Log, and invite you to send yours. We used those comments as a basis for the new format. You told us you wanted more SSDs, scenarios, fiction, and art. You got your wish! You said you wanted us to have some kind of "theme" to the issue. Since a given theme might be uninteresting to some players, the logical road was to have several "mini-themes" covering a broad range of ideas and interests.

Never hesitate to tell us just exactly what you want! And don't be too surprised if you actually get it! ☺☺☺

## STARLIST IS OPERATIONAL!

All known SFB players have been entered into a computer database. If you want your name listed, just send a postcard to Task Force Games and state your name, address, and phone number and that you want to be put on the SFB Player Contact List. Please do this on a separate page from all other correspondence so that we can hand it to the person managing the system and keep costs as low as possible. The list is arranged in zip code order. To obtain a copy of the list for your area, send a stamped self-addressed envelope and \$1 to Task Force Games and request the list for your area. (Please, this must also be separate from all other correspondence in order to keep efficiency high and costs low.) If you wish to obtain the list for an adjacent non-sequential area (perhaps across a state line), include the zip code there and another \$1. Players cannot order lists for non-adjacent states.

These lists are available only for non-commercial use to find new players for your group or a local convention and are not to be used for mail solicitation of products or other services. We cannot guarantee we will have listings in your home town, but we will have at least one listing for your home state.

If you contact TFG or ADB, you will automatically be put on the list. If you want your name deleted, just tell us. Send us a list of every SFBer you know! Years later, at least some of them will still be valid, and new gamers will be able to get in touch with your group.

We need new player listings in: Maine, Delaware, West Virginia, Alabama, Mississippi, Kentucky, Minnesota, Wyoming, Utah, Idaho, New Mexico, Oregon, Alaska, and Amarillo TX.

## PLAY AID INSTRUCTIONS

On the inside cover of this issue of Captain's Log, you will find an experimental new Energy Allocation Form. In this form, the space for writing in each turn's allocations is compacted to give space for various notes and other information. There is never going to be enough space for everything anyone could imagine putting on a form, but we tried to logically provide enough flexibility to adapt it to most ships. The various blanks and squares should be self-explanatory.

(We get new forms all the time, each proposing a "more logical" arrangement, but no two are alike, so there doesn't seem to be any reason to change the form.)

**GOT AN IDEA FOR A PLAY AID?** Then send it to ADB, and we'll consider it for a future issue. You don't have to write or draw the whole thing up; just a description of what you would like us to create and present will do fine. We have several suggestions in the file (ESG record form, expanded Klingon firing arcs diagram, an Impulse Chart that counts backwards, an F&E command ratings cross-index, and any number of new ways to keep track of drones). If you want to see one of those (or don't want it taking up space), drop us a line. ☺☺☺

## INPUT GUIDE: AN UPDATE

### NEW RACE PROPOSALS: NOT YET BUT SOON

In the near future, we will open the door once again for new race proposals. We are currently drafting the details of how these proposals must be presented, and hope to bring them to you in a future issue of Captain's Log. For now, continue to hold (and refine) your proposals and wait until we give the word. We must have all of the proposals in a specific format so that the selection process will be expedited. We got 135 entries the last time we had such a contest, and each one took most of a day to read, so we never were able to evaluate all of them. The new system will involve a summary sheet in a specific format that will allow us to set aside those with unsolvable problems and concentrate on those most likely to be successful.

### NOTES TO FICTION WRITERS

Do not use "lab" as a verb. Have the labs identify the drones; do not "lab the drones."

It's fun to invent interesting foreign words, but make sure that it is obvious from the context what they are. Undeleted expletives are self-evident, but if you say, "Give a J'llk to the gunner", you need to explain that a J'llk is a small tasty reptile. And you need to do this as part of the story, not in a footnote.

Please don't invent foreign words for such things as units of measure; that just adds another layer of confusion to the story. Oh, sure, the Air Force tapes that you are translating refer to a filahaburk, but translate that into kilometers for us, OK? A little local color makes a story exciting, but this needs to be interesting little anecdotes, not just running a search/replace command with the word processor. Wouldn't you rather have a Kzinti captain scream, "You leaf-eaters let that fighter get within 20Kkms" than "You idiots let that fighter get within 20 zingblits!" Now really, which one sounds more "science fictiony" and which one is easier to read? The same one? You're catching on!

Commanding officers should speak with a firm command voice (unless you are trying to show them as weak or scatter-brained). A captain does not say, "Oh, and by the way, load up another scatter-pack." He says, "Get another scatter-pack loaded immediately!" Individual captains might add a threat or exhortation to that, reflecting the way the crew has been trained before the story starts.

### PRIME DIRECTIVE

Players of Prime Directive should consult Prime Adventures #1 for detailed input instructions. ☺☺☺

## PLAYTEST UPDATE

### SP367 SHARKS!

Sharks are affected normally by EW (including EM) and have no EW of their own. Sharks can control eight seeking weapons but cannot accept or transfer control. Sharks are size class 5 for mines and type-VI drones. Each drone rack can regenerate one space of drones every 64 impulses, even if the rack is in use. PFs are treated like ships for damage but cannot be used for breeding. Size-6/7 targets hit by shark drones are treated as if they had been hit by a type-I drone. Sharks can HET, even while doing EM, with no reduction in speed and no chance of a breakdown. Spores do not leak through Andro PA panels but are absorbed until the panel is overwhelmed, at which point spore boarding attacks are treated normally. Sharks treat a web collision as a PF would (G10.594) but cannot break down and only take the damage. Sharks cannot be boarded or tractored. Thanks to Larry E Ramey for the questions that generated the above information. ☺☺☺



**AFTER ACTION REVIEW**

**CAPTAIN'S LOG #15:** People raved about the cover, the story, and just about everything else. Few companies provide "why" answers as Captain's Log does, and the Proposals Board is virtually unique in the industry, so these features remain very popular.

Brr'ev was one heck of a Marine, stuffing 50 Kzintis into a shuttle instead of the 30 the rules allow.

Rule (SL147.41) should refer to the "top left" not "top right".

Sam Clark's seeking weapon tactic confused some, but his intent was not to hit the Orion, only to keep him moving away.

The Kzinti battleforce has four T-bombs, not five. The WYN force should include a White Shark, not the tournament Black Shark.

In the timeline, the Tholians were attacked by Operation Nutcracker in Y177 but did not legally sign on to the Alliance until Y178, so both entries are correct.

In F&E, the Lyran thunderbolt tactic should include setting up a mobile base in 1407 and using a tug as a supply point in 1803 to keep the forces in supply.

On the F&E reference cards, the double conversion lines (e.g., RN->DG->RN) mean that you can convert an RN to a DG or a DG to an RN, not that you convert the same hull twice and end up with the same ship. Space was tight, and we combined two entries on one line. It costs 1 point to convert a Saracen into a Crusader. The NCV->CVM conversion costs extra for the fighters gained. IRQ and MHK are not available until Y176. The DG, MHK, and IRQ production costs include fighters. The Kzinti TGT is typoed as TFT.

**MODULE X1:** The most awaited SFB product of the year, X1 was an instant smash hit.

Annex #5: The Hydran CCX was originally named the Lord Governor, but this was changed to the Lord Bishop-X, and we missed one reference to the LGX.

R1.201 Tholian Starbase SSD: The web casters should have been lettered A, B, C, D, E, and F rather than numbered 13, 14, 15, 16, 17, and 18 as part of the phaser sequence.

R3.201 Klingon DX SSD: #5 shield should be 32 boxes, not 34.

R3.202 Klingon FX SSD: 'While' misspelled as 'whiel'.

R3.203 Klingon DXD SSD #5 shield should be 32 boxes, not 34.

R3.204 Klingon FSX SSD: 'While' misspelled as 'whiel'.

R3.205 Klingon D5X SSD: 'While' misspelled as 'whiel'. Needs the FH arc diagram.

R4.200A: The reference to (TP8.0) should be to (T10.0).

R5.201 Kzinti BCX SSD: The scanner track should read 0, 1, 2, 3, 5, 9 instead of 6, 4, 2, 3, 5, 9.

R7.202 Tholian CPX SSD: This ship's photons are correctly listed as having a range of 30. (The Federation did not provide the improved range versions.)

R7.207 Tholian DPX SSD: This ship's photons are correctly listed as having a range of 30.

R9.0: Some players complain that the Hydran X-ships are mis-BPVd as they are cheaper than non-X ships if you delete their fighters. In this case, the sum does not equal the total. When you buy so many fighters (or drones), you are in effect getting a discount.

R9.XF1: The Stinger-X has only the normal 2 points of built-in ECCM of a standard fighter; it does not gain the extra points allocated to X-ships under (XD6.0). This is implicit in that the rule refers to SHIPS, and not shuttles. Because of the effects of (J5.21), a Stinger-X fighter with a warp pack can achieve a speed of 31 even if carrying an additional pod and/or doing erratic maneuvers. No fighter, even an X-fighter, can move at speed 32 during a scenario, even if flown by an ace pilot (J6.23).

SH157.63: The reference to a Federation FFG should have been to the Federation CAR.

SH162.44: The reference to a PF shield refit is left over from the playtest version, in which one side had a PF, and should be ignored. The FKZ should be the FZX, but the entry should be ignored as the mech link is meaningless in this scenario.

SH164.2: The subunits of the B10S were accidentally left off of the scenario set up; these are a full flotilla of standard G1s including a leader and a scout [as mentioned in (SH162.423)] and a full squadron of 12 Z-YC fighters.

SH166.2: The Federation units all set up on Map A.

T10S3.461: The GBDPs are mistakenly listed as GBEPs in this rule.

XJ8.0: The X-MRS does not gain the extra points allocated to X-ships under (XD6.0). This is implicit in that the rule refers to SHIPS, and not shuttles.

**MODULE F1:** A surprise product no one had expected! The original submissions arrived back in 1986, including all of the basic concepts (galactic gypsies, asteroid ships, directional armor, anti-transporter field) to which ADB added the devastating rail gun weapon and the prospecting shuttle. Work had progressed at a low rate since 1989, and one day this spring Steve Petrick remarked to Steve Cole over lunch that it was ready for outside playtesting. The rest is history.

There were a few minor typos, but no major errors.

Annex #3: The DDS is listed as a DDC.

Annex #8B: Lists the LRG as LRF.

(D26.233): The reference to (E92.22) should be to (D26.22).

(R16.PF): For purposes of (K5.2), A is LRG, B is cargo, C is phaser-1.

(SG60.63): The reference to deleting a CW should be a DW.

(SG60.72): This rule should say to replace the DW with a CA or CW.

The Jindarians were the first of the races from the original 1986 contest to be published. Another race from that contest, the Vudar Enclave, is now in development. ☺☺☺

**ORIGINS '95  
NATIONAL GAME CONVENTION**

ORIGINS '95 will be at the Convention Center in Philadelphia on 13-16 July. SFB "Gold Hat" National Championships, F&E National Championships, and a major Prime Directive tournament. Total prizes will be over \$500, including cash, gift certificates, and 26 Rated Ace Cards! There will be seminars on Tactics, F&E, Prime Directive, and the SFB Universe. Info from Andon, P.O. Box 3100, Kent, OH 44240 or 1-800-529-EXPO.

**GENCON '95  
GAME FAIRE**

GENCON '95 will be held at Mecca Convention Center, Milwaukee, Wisconsin, on 10-13 August. While GenCon is mostly RPGs, it does include the largest SFB event outside of Origins (8 Ace Cards and the rank of Captain-General), plus an F&E event. GenCon hosts the Prime Directive National Championships. There will be seminars on Tactics, F&E, Prime Directive, and the SFB Universe. *And a better room than in 1994 (they promise)!*  
Info from P.O. Box 756, Lake Geneva, WI 53147.



## COMMAND THE FUTURE!

### STAR FLEET WARLORD: THE BOARDGAME

For years, players have told us they want a campaign system where every race gets a fair chance, an even start. Star Fleet Warlord will do that, and much more. The multi-section geomorphic map can be reorganized in hundreds of combinations, so you won't always have that nasty black hole in the sector next to you. You'll start with a "home office" (sort of a starbase) and a pile of cash, which won't nearly go far enough to buy the initial ships you need to find more sources of income to buy more ships to grab more territory to buy more ships to protect that territory from the enemy so you can use the income to buy more ships to conquer the adjacent territory.

The rules for the Warlord Boardgame are simple (16 pages of very big type) and will attract players of all levels. The first installment will include the Federation, Gorns, Klingons, and Romulans. Later expansions will bring in the warlords from across the Star Fleet Universe.

Details on price and release date were not available at press time.

**PRIME DIRECTIVE** is moving along smartly, with new releases planned throughout the winter and into next spring.

**5803 PRIME ADVENTURES #1:** This module will include new adventures for your Prime Team, taking them across the final frontier in search of glory and action.

**5812 EMPIRE OF STEEL (KLINGON SOURCEBOOK)** will tell you everything you need to know to run a Dagger Team, along with everything about Deep Space Fleet, ISF, ESS, home planets, titles of nobility, warrior philosophies, new skills (including that Klingon favorite: physical intimidation), and more!

**5804 HIDDEN AGENDA:** This campaign (multi-scenario) adventure takes place on Meva Station, a desolate and forbidding spaceport on the edge of nowhere. The mysteries which surround this station threaten to destroy your Team . . . and sanity!

### RED ALERT: THE STAR FLEET BATTLES CARD GAME

Now entering playtesting, this card game is planned to be as attractive as the "collector" card games but without the hype. Each of the ship cards is rated for the weapons that ship can fire, and about half of the action cards comprise various weapons (scoring various amounts of damage that are recorded by a handy sheet of die-cut counters). The other action cards include various special actions (damage control, electronic warfare) and maneuvers (high energy turn, erratic maneuvers) that can get you out of trouble. Details on price, packaging, and release schedule were not available as this issue went to press.

**CAPTAIN'S LOG #17** will be on the way to you in spring 95 with more all-new material. It will be \$14.95 and include 96 pages of goodies plus a full-color map, Stock #5713. Mini-Themes are scheduled to include: Seltorian X-ships, maulers for the ISC and Orions, and training new players (with new Cadet ships). Special Term Paper Sections are to include ISC and SFGs. You are invited to submit papers for these sections. When we do a special section, EVERY paper in the file related to that section gets sent to the grading panel, and any good paper sent to the panel gets published, so this is YOUR chance to get one published.

**MODULE Y: THE EARLY YEARS** should be along sometime in the late spring of 1995. It is scheduled to include two "new" races, the Early Hydrans (just waiting for the Klingons and Lyrans to come wipe them out) and a bird-like race from the galactic core. Watch for it!

☆☆☆

## MINIATURES ARE BACK!

The first of the new STAR FLEET 2300 MINIATURES have been sold at conventions and by mail, and the first three packs are to reach the stores very shortly.

When TFG began releasing miniatures at Origins, they included new ships done specially for SF2300 (a metal Federation CA and a one-piece Klingon), new production from the molds of the previous Starline 2200 series (e.g., Klingon F5), and new ships done for Starline 2200 but never released (the Klingon B10V and Romulan Firehawk). This delighted, and confused, players across the country. Here is the whole story so that you can see there is method in our madness.

There are a lot of ships in SFB, and getting a full range deployed for Star Fleet 2300 could take over 100 different ship designs. TFG's bold plan called for attacking this massive challenge from every direction at once. New sculptors have been hired to produce entirely new ships never seen before. The "masters" (the metal forms used to produce the production molds) for the old 2200 series were scheduled for retooling and upgrading to add more detail.

Most of the Starline 2200 molds still existed, and these were sent in groups to a casting company with orders to produce as many as they could. Molds do not last forever, and these molds could not produce more than a few hundred of each ship before breaking down. (Also, these molds are set up for lead, and the retailers now expect pewter figures.) TFG President John Olsen ordered this limited production from the old molds in a lead/pewter mix for several reasons:

- To satisfy demand that had built up for years.
- To test the market and see if there still was one.
- To build excitement and attract interest.
- And to generate business activity to support the new production and sculpting.

You, the players, have responded by enthusiastically snapping up just about everything TFG can get from the casting house. These were sold only by mail because the molds could not produce more than 1/10 of the number needed for the first day of sales through the stores, and the ships weren't pewter.

The next step is the release of a special package of ships: Federation CA, Klingon D7, Romulan War Eagle, and Tholian Patrol Corvette. (Because these were all on TV, they have the best chance of storming a beachhead on the retail shelves.)

After that, we will begin releasing "fleet packs" for each race, along with selected ships released in individual blister cards. This will solve the major problem that brought the old 2200 line to a standstill. There were not enough ships to cover every type needed, but some ships (e.g., tugs) did not sell as well as others (e.g., cruisers, frigates). What retailers could not fathom (but which was obvious to players) was that each fleet needs many cruisers and frigates but only one or two tugs. The retailers wanted the slow-selling tugs dropped, but without them you, the gamers, would not buy the hot selling cruisers. By including the tugs and DNs in the fleet packs and ALSO selling the cruisers and frigates as individuals, we'll give the gamers what they need and the stores what they want.

Available now are the new metal Federation CA, the Gorn CA, the Hydran Lancer and Ranger, the ISC CA, the Orion CA, and the Tholian CA and PC. The Klingons have the B10V, D7 (one or multi piece), and F5. The Romulans have the new Firehawk, the veteran SparrowHawk, a new War Eagle, and the Battlehawk (which was the War Eagle in the 2200 series).

TFG has also released the first prototypes of a second series of miniatures, the tiny 1" long "Megahex range" which can be played on Megahex maps. The plan is to release a pack containing the tournament cruisers for each race.

☆☆☆



NEW SHIPS

All ships published in Captain's Log are subject to further refinement based on YOUR playtest reports. Using these ships in your local campaign is subject to the usual warnings and risk.

**(R2.960) FEDERATION LIGHT MAULER (NCM):** A conjectural ship found in Star Fleet archives where it was postulated as a counter to the Jindarians. Spare shuttles 2, Year in Service 175, docking points 6, explosion strength 19, command rating 6, Notes: +. NOTE: The Federation heavy cruiser mauler *Velikovsky* was in Starletter #91.

**(R2.206) FEDERATION DGX:** The was the drone-armed version of the X-destroyer. It retained two photons for direct combat and was intended to stand in the squadron's battle line rather than operate alone. The spare shuttles, explosion, docking, and command ratings (etc.) are the same as the DDX.

**(R3.206) KLINGON D5XD:** The Klingons built the first of these powerful scout/drone ships for independent bombardment missions (copying the Kzinti CMDX), but ended up using the handful that were built as fleet scouts in direct combat (as the Kzintis did), where they were powerful anti-drone platforms. The sensors were certainly far more than needed for bombardment targeting, so perhaps this was the Klingon intent all along. Spare shuttles 1, Year in Service 183, docking points 7, explosion strength 17, command rating 8, Notes: ♦, DB.

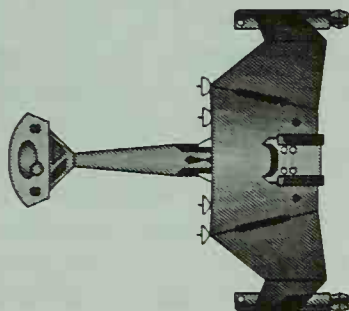

**(R5.933) KZINTI MAULER BATTLECRUISER (BCM):** A conjectural design intended to provide a Kzinti mauler for local campaigns. Spare shuttles 2, Year in Service 175, docking points 7, explosion strength 25, command rating 8, Notes: +. NOTE: The Kzinti Medium Mauler was in SubSpace News #4.

**(R6.923) GORN MAULER MEDIUM CRUISER (CMM):** A conjectural design intended to provide a Gorn mauler for local campaigns. The design is related to the Heavy Destroyer Mauler published in SubSpace News #4. Spare shuttles 2, Year in Service 175, docking points 8, explosion strength 26, command rating 8, Notes: +.

NOTE: The Tholian MCW mauler was in SubSpace News #4.

**(R9.934) HYDRAN HEAVY MAULER CRUISER (CAM):** A conjectural design intended to provide a Hydran mauler for local campaigns. Spare shuttles 2+2, Year in Service 175, docking points 9, explosion strength 25, command rating 8, Notes: +. NOTE: The Hydran MCL mauler was in SubSpace News #4.

**(R16.40) JINDARIAN HEAVY SHIPYARD CRUISER (CAD):** The Jindarians built their size-4 ships in portable shipyards contained within asteroid ships. The heavier of the two types was able to build (or dock for repairs) two destroyers or frigates simultaneously. The ships dock using (R16.1E). The ancillary data (spare shuttles, explosion, docking, command, etc.) is the same as for the standard heavy cruiser.

**(R16.41) JINDARIAN LIGHT SHIPYARD CRUISER (CLD):** This was the smaller of the two shipyard cruisers. Being smaller, it could only dock one destroyer or frigate at a time. The ships dock using (R16.1E). The ancillary data (spare shuttles, explosion, docking, command, etc.) is the same as for the CL.

DECISIONS

OF THE STAR FLEET UNIVERSE BOARD OF PROPOSALS

**LONG LANCE PLASMA (1601B):** J. J. Miranda proposed a version of the plasma-D that could travel hundreds of hexes for bombardment missions. This would give the plasma side of the galaxy something to match the Long Lance drones on the other side. This was rejected because plasma torpedoes lose power with range and burn out completely at 32 hexes.

**BEST OF BOTH EMPIRES (1602B):** Mike Stiles proposed a Klingon D7C rear hull with a Federation GSC saucer. While interesting, the engineers insisted that a saucer could not be linked to a Klingon rear hull.

**BATTERIES TO GO (1603B):** Gregg Dieckhaus proposed a general refit for all races, giving all ships enough batteries to make a high energy turn on reserve power alone. This was rejected because it destroyed the flavor of the game. Players are supposed to work around the limitations of their ships, not invent new refits to make them disappear.

**ANEMONE DRONES (1604B):** Ken Burnside proposed a Kzinti drone that used Hydran implosion technology to damage non-facing shields. This was rejected for several reasons. It was doubtful that a hellbore warhead would fit on a drone. It complicated tactics unnecessarily. It expanded enveloping weapons to virtually every race that didn't currently have one.

**BALLISTIC PLASMA (1605B):** Kelly Donahue proposed that plasma torpedoes be allowed to use the ballistic targeting rules of type-III drones in (FD5.252). This was rejected because plasma torpedoes are not quite smart enough to seek their own targets and the type-III drone is intended for long-range use, and plasma torps do not have the range to need such a system.

**DOUBLE YOUR T-BOMBS (1606B):** Michael Stiles proposed a special rule usable in only extreme and rare conditions under which T-bombs could be placed in the spaces normally reserved for Dummy T-bombs. The problem is that Dummy T-bombs and Real T-bombs are not the same size or shape and do not require the same "support facilities" to monitor them and keep them safe. (After all, you are talking about carrying around a thermonuclear bomb.)

**SUICIDE SHIPS (1607B):** Stephen Hill proposed a rule that would allow ships to blow up near the enemy to cause extra damage, unaware that this used to be in the rulebook and was deleted in the Captain's edition because it produced unrealistic tactics.

**SLIP-SLIDING AWAY (1608B):** Stephen Hill proposed a rule by which ships would coast on their momentum and could also turn to face a direction other than the one they are traveling in. This works, of course, but only at very slow speeds that would take many turns to move one hex.

**AND LEST YOU THINK WE REJECT EVERYTHING,** we have, recently, accepted a dozen scenarios, a couple of new ships, several new races (Jindarian, Vudar, "coreward avian"), a new boardgame, and a few other things. ☺☺☺



## TO ASK THE QUESTION... WHY?

As is well known, questions beginning with "why" cannot be answered in the Question & Answer system. Such explanations take too long and aren't really necessary to resolve rules questions and get on with playing the game. We do take note, however, of the more important, frequent, and interesting questions and try to provide answers in Captain's Log.

### QUESTIONS ABOUT BPVs

*Why is the LDR BC so cheap compared to other BCHs which cost the same but have less firepower?*

1601W: Because of the deployment limits on LDR ships.

### WHY FIGHT IN DEEP SPACE?

*Our group ran into a philosophical question the other day. Why would any ships ever fight anywhere except at a planet (or a base that cannot move, or a convoy that cannot move very fast)? Why wouldn't every duel end on Turn #1 with one or both ships just leaving? Why do duels ever happen anyway, since they typically leave one ship destroyed and the other headed for a six-month overhaul.*

1602W: This is largely a matter of the way wargames work. A real commander has 1/10th of the knowledge that the typical gamer has about what is going on and what the objectives are. Most gamers are fairly bloody-minded and don't set up a scenario if they plan to boogie on Turn #1. Perhaps there is a convoy "over there a few maps", and leaving would let the enemy attack it? In a real war situation, you never want a fair fight. You want five of your ships beating up one of his so that he is so overwhelmed that none of your five ships will be damaged. It's hard, however, to find a gamer willing to be on the short end of the theoretically most typical battle.

### FRACTURED RUSSIAN, COMRADE?

*Why did you put "Big Star Warships" on the R5 rulebook?*

1603W: It's true, isn't it?

*No, I mean, why did you do it in Russian?*

1604W: We're all one big happy planet in the future, working together as friends and comrades. We didn't want the Russians to feel left out.

*Why is your Russian grammar so fractured?*

1605W: Blame it on two military intelligence officers, neither of whom speak Russian, looking it up in a Russian-English dictionary in a scene reminiscent of a certain starship crew trying to look up a Klingon phrase. We are, by the way, trying to find the Basque translation for "Module R6: More Ships" since no one is likely to be able to tell we screwed that up.

### MASTER SHIP CHART QUESTIONS

*Why are the ships listed in class order instead of by date of availability?*

1606W: We organized the data in the most logical fashion for use by everyone. If you want to find a DD, you look under DDs, not down the list of years until a DD shows up. Seriously, some have asked for MSCs based on BPV, on availability dates, on function (scouts together, carriers together), by rule number, alphabetically, and on a whole host of other parameters. We cannot print every version of the chart (wait, maybe that could be a 200-page Mail Order Module? Nah.), and hull type seems the most logical for general use.

### WHY WON'T YOU ANSWER ME?

*How big is Tholia? You know, the Dyson sphere?*

As big as it is. Why does it matter?

*I want to know! Why won't you answer me?*

1604W: Because (and this is obviously an example of a type of question, not just one specific question) we don't "need to know" at this point. Figuring out how big Tholia is amounts to more than picking a number. You have to have something that makes some scientific sense (even if you have to invent new materials and ways to make a real tiny star), but it also has to make gaming sense (based on weapons ranges, how many weapons are there, just what an F&E defense battalion is, etc.). These questions become very complex and take quite some time to answer. There is no tremendous urgency at this point, although we will have to face it someday (when we do the Tholian Sourcebook for Prime Directive, at latest). Right now, the time would appear better spent on projects already promised. To just pick a number out of the air, just to get the person asking the question to go away, means that someday when we "design" (rather than just guess) the size of Tholia, we might very well be "proven" to be "wrong". That would mean changing "officially decided" information, which is even more annoying than refusing to answer. We might not know the answer to every question, but if we give an answer, we would like to give the "right" answer, and to do so in the confidence that it will STAY right. Now, some have suggested assigning the problem to a staffer. We did that once, assigning it to two staffers. They came up with different answers, and each argued endlessly over why his answer was right. I recently asked a real scientist and got an entirely different answer (along with proof that it was right). Then another scientist "proved" that his (different) answer was right. Ultimately, it came down to Steve Cole making the decision, and Steve refused to do so without a full-scale study of the problem (i.e., design the scenario), which he has not had time for. Someday someone will come up with a really cool campaign that only works if Tholia is a certain size, and we'll find a scientist who can explain it. ☺☺☺

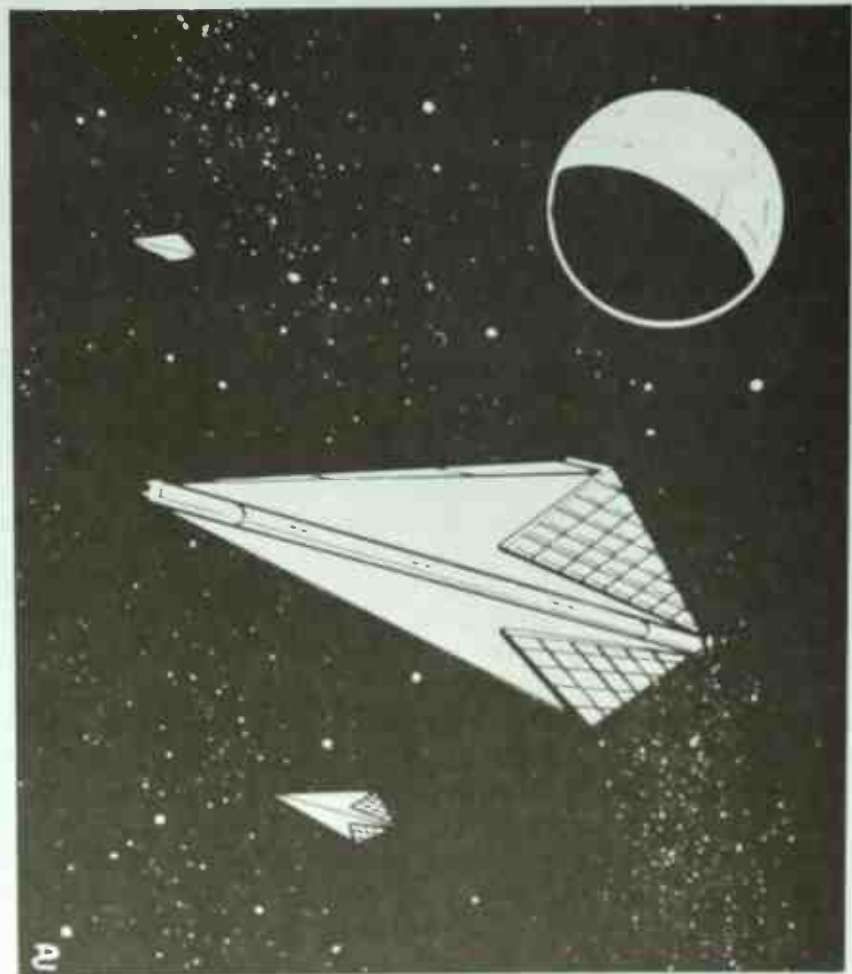



# ASK KOMMODORE KETRICK

This is our Rules Questions Department, with answers provided by Steven Paul Petrick, ADB's Chief of Staff. Interesting questions received by ADB are selected for this column to help explain some of the more obscure or complex rules.

## MAULERS

**Q1601:** Under (D23.242) should "... from the batteries or power absorber panels ..." read "... from the batteries and/or power absorber panels ..." or is it just my imagination?

**A:** It is and/or within the restriction that the total power you can fire and not roll for shock is limited to less than 1/3rd of the battery capacity, not the battery and panel capacity combined.

**Q1602:** Could I fire 0.5 (or a little more) points from my power absorber panels? What if someone filled my panels after I did this? Would I take 0.5 of an internal?

**A:** See (E8.321) for fractions fired through a mauler. In the case of the 0.5 point, if a 0.5 point of damage leaks through, it becomes a full point of damage taking a 0.5 point with it. You gain no benefit by having a 0.5 point of power in your panel in terms of blocking internal damage, no more than a galactic ship would gain anything if it reinforced a shield with a fractional point, unless that fractional point were augmented from batteries when the damage was taken.

**Q1603:** Can I fire up to 20 points of energy from my panels the instant that they appear in my panels (i.e., during the same impulse 6D2: Direct-Fire Weapons Stage)?

**A:** No, since when you allocated to fire in the Fire Decision Step, you could not have known the power would be there. You cannot fire the energy that your opponent just placed in the panels in a direct-fire stage until the following impulse. You could fire energy that was placed into the panels on that impulse by mine explosions, seeking weapons, and ship explosions from movement related damage or a self-destruction blast during the immediately preceding Energy Allocation Phase.

**Q1604:** I am a little confused on (D23.24) Maulers (shock effects), especially about (D23.242). Does (D23.242) mean that your first firing of "your wad" (all batteries and power absorber panels only) requires no shock roll? Does it also mean that you could do this every 33 impulses with no shock effect (e.g., fire on Impulse #15, then on Impulse #16, Impulse #17, etc.)? Otherwise, I would be able to fire a maximum of 14.5 points of energy within 32 impulses of each other and have no shock roll (this includes PA panels with 20 points and batteries at full power; 13 points without the panels). Is this right?

**A:** No, what it means is that if in any period of 32 consecutive impulses you fire less power through your mauler than 1/3rd of your total battery capacity, there is no shock. If you fire all of it in one salvo, that salvo has at that point exceeded the 1/3rd rule. If your batteries would hold 30 points of power, and you fired 9 points (and no more) of it through the mauler, you take no shock damage. If on Impulse #1 you fire 9 points through the mauler, and then on Impulse #32 you fire one more point, then you have fired 1/3rd of your power in 32 consecutive impulses and you roll for shock. Note that this applies if you fire 9 points on Impulse #16 of one turn, and then on Impulse #15 of the following turn you fire one point. It is still 1/3rd in a period of 32 consecutive impulses. Note specifically that you can draw 9 points from your panels, but this 9 points counts as the 1/3rd from your batteries for the next 31 impulses.

## TUGS AND LIGHT TACTICAL TRANSPORTS

**Q1605:** Are the costs for tug and pod combinations just the addition of the two? Can you put such pods as the Federation battle pod or heavy carrier pod on an LTT (i.e., heavy pods on LTTs)? Also could you put a Federation battle pod and a light carrier pod on a battle tug?

**A:** Unless a specific BPV is given (such as for some battle and carrier tugs), you simply add the BPV of the pod and the tug together. Federation LTTs can carry one single weight, or one double weight pod, but not both.

A Federation battle tug might have a light carrier pod added to the rear of the battle pod, but a Federation carrier tug cannot have a light battle pod added on behind it (the photon arcs would be blocked).

In the case of adding a light carrier pod to the battle tug, we already published an SSD; see (R2.78) in Module R5.

**Q1606:** As some tug pods can operate as a size class 4 ship, should they have their own T-bombs as done on the Advanced Missions Federation carrier tug SSD?

**A:** You misunderstood. Adding the heavy carrier pod makes the carrier tug a size class 2 ship, gaining two T-bombs for size, not for the pod.

## NON-VIOLENT COMBAT

**Q1607:** Under non-violent combat (D6.4), a drone hit is under the Weapon Systems Hits Chart (D6.411). Does this also apply to power absorber panels?

**A:** Yes, a drone hit on the non-violent combat table will destroy a power absorber panel on an Andromedan. It is what comes from their other than Galactic technology.

**Q1608:** Last night using non-violent combat, my Andromedan ship had all of its power taken away and some power left in panels. This meant that destruction was imminent. Is there any way to prevent this? All batteries were destroyed, and it only had a few internal boxes left.

**A:** To all intents and purposes, non-violent combat does NOT work against Andromedans until the panels have been destroyed. You must remember that their panels are shields, and while there is some damage caused by power surges, that damage is totally random and resolved by the regular Damage Allocation Chart. You cannot score non-violent combat damage on an Andromedan until the panel bank on the side of the ship that you are engaging is either overloaded allowing leaks or destroyed.

That being the case, by the time you get to where you can score non-violent combat damage, the Andromedan ship is probably already beginning to cascade to death. In a normal game, or a non-violent combat game, if there is no power to operate the panels, cascade occurs and there is not a bloody thing you can do about it.

Your only chance of survival is if the cascade does not cause the ship to blow. Other than that, there is nothing you do but hang on and pray (if Andromedans pray).

## MULTI-ROLE NEEDLES

**Q1609:** MRN PFs, can the Minelayers still carry mines? If so, how many? What type of fighters do the MRNs with fighter boxes carry?

**A:** Like all Fi-Cons, MRNs have whatever kind of fighter you take away from some poor carrier and assign to the Fi-Con. Fi-Cons carry fighters; they are not born with them. Same deal with the mine-laying MRNs; they take mines from some ship. Since most ships cannot have NSMs (only T-bombs), most MRNs have only the T-bombs from the mothership or some other ship. Once the MRN loses the mine pallets, it loses all ability to carry mines unless it was the leader MRN to start with, in which case it can still carry its normal one T-bomb.



## MANEUVER

**Q1610:** Assume that on Impulse #16 a ship declares emergency deceleration. On Impulse #17 it is required to move as per the emergency deceleration rules. After this move, this ship chooses to fire during the Direct Fire Phase. Because of its last move, it now faces an ambiguous, i.e., "down the line", shield shot on its intended target. (D3.41) requires that the next ship that will move is temporarily moved forward one hex to resolve the situation. The problem here is that at this particular instant the ship is at its undecelerated speed, while next impulse it will be at speed "0". Some of our players argue that for the purposes of this calculation the ship in question should be considered at speed "0". Others argue that the ship is not decelerated until the next impulse, so its current, i.e., undecelerated, speed should be used to resolve the situation. Which point of view is correct?

**A:** Basically, in the situation you have described, the ship which is executing the emergency deceleration has not stopped and will not stop until the next impulse. For all purposes, a ship which announced that it was emergency decelerating on Impulse #16 is still considered to be moving at whatever its speed was on Impulse #17.

**Q1611:** Say ship A and ship B are on a split shield. Ship A announced emergency deceleration on Impulse #15 (it's currently Impulse #16) and will not move again. What happens to the shield facing [under (D3.4B1)] if the next ship to move would normally be ship A, but because it emergency decelerated it does not move? This was the actual game situation. Impulse #15: My friend (moving speed 26) announces emergency deceleration. Impulse #16: I announce a speed increase to 1 (formerly facing). We have a split shield at this point. I did the speed increase because a speed 26 unit does not move on Impulse #17, meaning my friend will not move for the rest of the turn due to the emergency deceleration, which means I, at speed 1 (moving on Impulse #32), am the next unit to move and thus keep him off my down shield.

**A:** I cannot fault your logic and would be forced to say that you have effectively covered your shield because of the way (D3.41B) reads, but only after the emergency deceleration has taken effect. Because of the way (C8.31) is worded, if your friend fired on your ship during Impulse #16, he will still be the next ship scheduled to move and his movement would govern his shot. At the end of the Movement Step of Impulse #17, under the provisions of (C8.101), he is stopped and your speed then becomes the governing factor.

**Q1612:** If the Post-Deceleration Period after emergency deceleration (C8.4) extends over a turn break, can a captain plot tactical maneuvers for use during the remaining Post-Deceleration Period? Or would the energy that is allocated for the tacs be transferred to the shields as in (C5.51), even though there has been an Energy Allocation Phase? The way I read (C5.51), it is referring to situations where emergency deceleration effects end before a turn break.

**A:** The ship can pay for and use tactical maneuvers normally during the Post-Deceleration Period. (C8.412) provides that even if a mid-turn speed change (C12.0) is to be used to begin moving on a subsequent turn, the cost of the move is paid for the entire turn. However, it notes that the ship is considered, during this period, to still be at zero speed, and so long as it is at zero speed, it can use tactical maneuvers.

**Q1613:** Assume a ship has allocated for 1, 2, 3, or 4 tactical warp maneuvers in a turn. What is the maximum speed he could increase to using (C12.0) for Impulse #9? Is it 11, 12, 13, or 14?

**A:** As tactical maneuvers are done at speed 0 and do not count for acceleration, the ship would be able to accelerate to a maximum speed of 10, and no faster than speed 10, for 32

impulses from the point where it accelerated to speed 10. See (C2.25). Note that PFs and X-ships could do better than 10.

**Q1614:** Tell me if I interpret (C3.44) correctly in the following example. My Federation CA ended its turn in which it had moved at a constant speed of 12 with its turn mode fulfilled, but because of current tactical circumstances turning was not a good option. At the beginning of the next turn, it accelerates to speed 24. Does this mean:

A) I have to move two more hexes further forward before I can turn? OR

B) I have to move five hexes before I can turn?

**A:** A is the better answer, but is not the best answer. The best answer is that the ship must move a total of five hexes since its last turn (not game turn) before it can make a turn at its new speed of 24. Barring an HET of course.

**Q1615:** Although I can't find the reference, I seem to remember reading something like, "There is a bit of impulse power in every hex moved. Warp power produces an envelope in which movement is made, and impulse power actually moves the ship within that envelope." If this is true, what about a situation where internals have obliterated all of the impulse boxes but some warp boxes remain? Does this mean that the ship is effectively dead in space as it has no impulse to move within its warp envelope? Please clarify.

**A:** No, it is not dead in space. For one thing, such background may explain rules but is not itself a rule. For another, engine damage does not take effect until the end of the turn unless using Energy Balance Due To Damage, and only sado-masochists do that. For yet another, explaining how impulse moves you around in the bubble does not mean that without impulse you cannot move at all. Without impulse, you cannot move by impulse power, and that is all. ☺☺☺



COMMODORE KETRICK GREETs A  
NEW ALIEN SPECIES WHILE ON  
A SCIENTIFIC SURVEY MISSION



## COULD YOU GIVE ME AN EXAMPLE OF . . .

by Bruce Graw

### BRAKING/QUICK REVERSE?

A Federation destroyer moving speed 6 needs to reverse direction quickly. The Federation player needs to keep the destroyer's photons facing the enemy as the ship retreats, so an HET is inappropriate. Mid-turn speed changes (C8.0) are not in use in this scenario, so the ship cannot mix forward and reverse movement in the same turn (C3.51). The player must therefore wait until Energy Allocation to reverse direction. Emergency deceleration (C8.0) is not used as this would force the ship to remain stopped for 16 impulses (C8.41), which the destroyer cannot afford to do in this situation.

During the Energy Allocation Phase, the player notes that under (C3.52) his ship must pay a "braking energy" cost equal to its speed on the previous turn (based on the cost of movement, not the number of hexes of movement). Since the destroyer has a movement cost of 1/2 and its previous speed was 6, the braking energy cost would be 3 points of power, which must be warp energy (C3.52) except for 1 point that could be impulse power (C2.111). Note however that using impulse power in this case would require an extra one-half point of total power since impulse can only move the ship 1 hex.

The player decides to move speed 10 in reverse, which is his ship's maximum possible speed because the act of braking reduces its speed to 0 (C3.522), and the maximum increase is 10 (C2.21). This costs 5 points of warp energy. However, with all the other activities the ship is performing, only 2 points of warp power (and no impulse power) remain to pay the braking cost. This leaves a shortage of 1 point of energy, which is the cost of 2 hexes of movement.

After Energy Allocation, the player rolls a die at the start of Impulse #1 (C3.61), getting a 2. As this is equal to or less than the shortage of movement points, the ship suffers a breakdown. Had the ship been nimble, it would have had a +1 bonus (C11.25) and would not have broken down. Unfortunately, the breakdown bonus (C6.52) is used for HETs only (C3.63) and cannot be used to protect the ship.

The ship suffers all breakdown penalties, and might even tumble, as explained in (C3.61).

### EMERGENCY DECELERATION?

During a particularly critical moment in combat, a Romulan King Eagle launches a plasma-R torpedo at a Federation cruiser 3 hexes away. Realizing that this means the plasma-R torpedo launched at another ship earlier in the turn is probably a pseudo-plasma, the Federation captain orders emergency deceleration (C8.0). This can be ordered on the same impulse as the plasma appeared because plasma launch (step 6B6 of the Sequence of Play) comes before emergency deceleration is announced (step 6B11, Final Functions Stage). The controller notes that deceleration was declared on Impulse #20 of the turn.

On Impulse #21 the Federation ship moves normally and takes the opportunity to fire (it will be his last chance to do so before wild weasel launch occurs). Then, on Impulse #22, the ship moves again and comes to a halt during step 6A4 (Final Movement Actions Stage) of the impulse. As it happens, the plasma torpedo is now 1 hex away. Note that the required 2-impulse period (C8.101) has elapsed with the passing of Impulses #21 and #22.

Consulting the Impulse Chart, the player observes that his ship has 4 unused hexes of movement remaining, which con-

verts to 2 points of shield reinforcement (C8.102). The ship had also paid for erratic maneuvers (C8.0) but had not yet used them; these points are lost (C8.23), and no reinforcement power is earned. The player chooses to place his reinforcement on shield #4. Then he launches a wild weasel off his #4 shield, i.e., in such a way that any collateral damage will strike that shield (J3.303).

After emergency deceleration has taken effect, the ship may not move again for 16 impulses (C8.41), which will last through Impulse #6 of the following turn. If the captain decides to accelerate to speed 10 during that turn, it will have to pay for a full turn (C8.412) at speed 10 even though the move on Impulse #4 would be lost. A mid-turn speed change to 10 on Impulse #6 would not avoid this penalty because, during the non-moving period, the ship pays for movement at the highest rate it will move during that turn (C8.412) — in this case, speed 10. Although the ship cannot move out of the hex until Impulse #7 of the next turn, it can make tactical maneuvers (C5.51), but these must be paid for with reserve power since the act of decelerating cancels all plotted movement (C8.102). Reserve impulse power (H7.47) could pay for an impulse tac as early as one impulse later (Impulse #23 in this case), or reserve warp (H7.4) could generate a warp tac after four impulses (in this example, Impulse #26). Of course, if power had been allocated for an HET (or could be drawn from reserve power), an HET could be done on the impulse after the ship comes to a full stop, i.e., there is no delay (C5.54).

### DAMAGE CONTROL?

A Lyran BCH is attempting to repair as many of its systems as it can in as short a time as possible.

Under (D9.2), the ship can repair shields by expending 2 points of power per shield box repaired. The maximum amount of energy that can be expended is equal to the highest undestroyed number on the damage control track (D9.21), in this case 6. The BCH spends 6 points of power and repairs three shield boxes. This type of repair is independent from the other methods of repair described below and can be assumed to continue throughout the example, restoring three shield boxes at the end of each turn.

Several shuttles have been damaged in combat and recovered by the ship. Although the Lyran BCH does not have deck crews formally assigned by Annex #7G, (J4.814) provides the ship with two deck crews by default. A deck crew can perform one action per 32 impulses (J4.823) and can repair 1 damage point on a shuttle as an "action" (J4.818). The deck crews can work on different shuttles or team up to work on one shuttle (J4.8172) together. This type of repair costs no energy and, like the shields above, is independent of all other repairs.

The ship also wishes to use continuous damage repair (D9.7), also known as "CDR", to repair systems. The player notes that (D9.76) limits CDR to at most six systems (the highest number on the ship's damage control track) during the scenario, a significant limitation. The damage control track generates 6 repair points per turn at no energy cost (D9.72), but no more than 5 may be applied to any given system during a turn (G17.33), and only one box may be worked on at a time (D9.741). Therefore, the Lyran player can either choose to repair small systems or work on large ones and lose the excess repair point. Consulting Annex #9, the player notes that phaser-3s cost a mere 2 CDR points to repair, and he chooses to use Hasty Repairs (G17.5) to repair phaser-1s as phaser-3s. He fixes three of them in each of Turns #1 and #2, expending all available CDR points in those turns and using all six available CDR repairs in the scenario (D9.76).

On Turn #3, the player begins to use Emergency Damage Repair (D14.0), abbreviated EDR, to attempt to repair a number



of destroyed warp boxes. EDR could not be used before this turn because CDR was being used, and the two may not operate simultaneously (D14.26). EDR uses power fed through the labs (D14.12) at a rate of 3 points of energy per lab box in use. The Lyran has four labs and chooses to spend 12 points of energy, earning four EDR rolls. He marks one of the 4s on his damage control track destroyed (D14.11) and, at the end of the turn, gains four rolls to repair warp boxes. If any of these rolls is a "4" or less (the number marked destroyed on the damage control track), the warp box is repaired. Note that the player could have used a "2" (though his chance of success would have been reduced). He could also have used the lone "6", but since (D14.21) limits the success roll to a maximum of "5", and the track has only one "6" available, the player judges it is not worth wasting it at this time, besides he is still repairing shield boxes.

On Turn #4, the player tries the exact same EDR procedure as he did on Turn #4, but his labs are destroyed by hit-and-run raids, and according to (D14.13) those attempted repairs are lost. Because of this and the (D9.76) limitation, the ship is no longer capable of repairing itself with CDR, and its ability to use EDR during this scenario is limited to using a single control box (G4.33). Unfortunately, it cannot use its repair boxes on itself because of the restriction of (G17.121), which limits PF Tenders with repair boxes to repairing PFs and shuttles only.

If a PF were docked to the BCH, the ship could use the repair boxes to repair that PF. The procedure is simple: 1 point of power allocated to each repair box provides 1 repair point (G17.21). Unlike CDR, however, these points can be allocated to different systems (G17.314). The repair boxes could also be used on shuttles (K2.611) aboard the ship. Note that the maximum number of repair points that could be generated during the scenario is 100 (K2.611).

### RESERVE POWER?

In a tournament battle, a Federation TC wishes to have 5 points of reserve warp power available to employ an HET if needed. To do this, he must allocate 5 points of warp engine power (not AWR power) to recharge batteries (H7.41) and, of course, the ship must have five undamaged batteries. Any power already in the batteries must be discharged before they can be recharged. Therefore, on the Energy Allocation Form, "Batteries Discharged" is listed as 5 points and 5 points are then allocated to "Recharge Batteries," with a "W" next to the "5" to indicate that this is reserve warp power.

Due to this method of designation, the Federation ship will appear to have a total power of 43 (5 more than the 38 provided by its warp, impulse, and AWR), but since these points were immediately used to recharge batteries, it has not really gained anything. Note: This may appear redundant or superfluous, but is an absolute requirement, especially in tournaments. If the batteries are not noted as discharged and recharged with warp power in this manner, the judge will rule that reserve warp power was not available to your ship.

If a point of reserve impulse power (H7.47) was desired, possibly for use as an unplotted tactical maneuver after emergency deceleration (C5.531), the same procedure above could be used, marking the reserve impulse point with an "I" instead of a "W". Take care that the "I" is not confused with a "1" (one) on the Energy Allocation Form.

During Turn #1, the HET is not needed, but the Federation player chose to use 2 of his reserve warp points to overload a photon torpedo. These are recorded at the bottom of the Energy Allocation Form as battery points expended during the turn. On Turn #2, the battery power available will be 3, not 5, so the ship will "appear" to have a total of only 41 points of power available after the remaining three batteries are discharged during Energy Allocation. If all five batteries are to once again be charged as

reserve warp, the Federation player will find his ship short 2 points of energy (as compared to the previous turn). Obviously, using reserve power is like "robbing Peter to pay Paul" and should not be used frivolously.

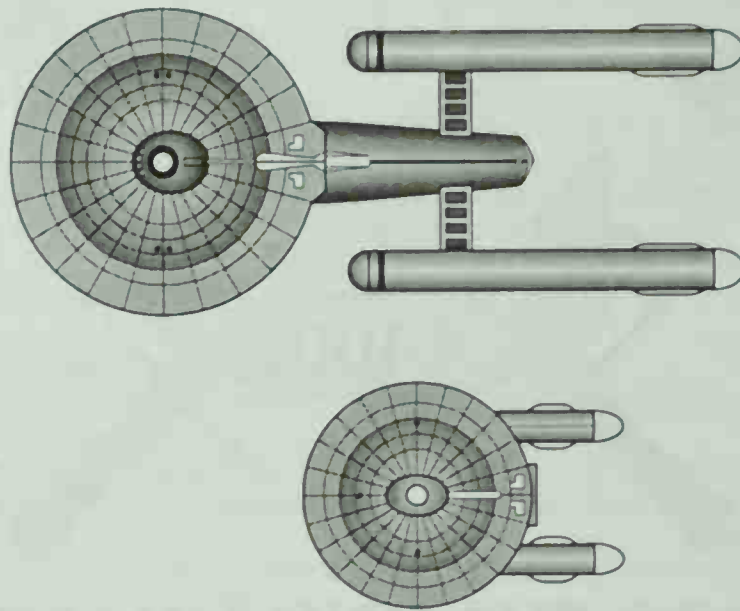

### PHOTON TORPEDO ARMING?

Four photon torpedoes are being armed by a Federation CA. On Turn #1, photon A receives 4 points of energy, and photons B, C, and D each receive 2 points of energy. All of this must be warp energy (E4.21). Photon A must be completed as an overload (E4.4), or discharged, although the others can be completed as standards or proximity-fuzed types (or even as overloads if enough power is used) on Turn #2. However, this decision does not have to be made on Turn #1.

On Turn #2, photon A receives 2 points of energy, completing the torpedo as a 6-point overload, which gives it a warhead of 12, feedback damage of 2, and a holding cost of 1.5 (E4.413). Photon B receives 2 points of energy and is completed as a standard load (E4.21). Photon C also receives 2 points but is armed with a proximity fuze (E4.3), and a "P" is marked next to it on the Energy Allocation Form to indicate this. (If a "P" is not marked, any judge will rule the photon has a standard load.) Photon D receives 6 points of energy and is fully overloaded, with a 16-point warhead, feedback damage of 4, and a holding cost of 2 (E4.413). Note that if additional energy to load the torpedoes was not allocated, the energy already allocated would be lost (E4.22).

None of the photons are fired on Turn #2. On Turn #3, photon A is held for a cost of 1.5, and 1 more point of overload energy is added, making it a 7-point photon with a 14-point warhead, feedback damage of 3, and a holding cost of 1.75 (E4.413). On Turn #4, if it is not fired during Turn #3, this costs a total of 2.5 points of energy, but only the added point must be warp since photons can be held with power from any source (E4.23).

Meanwhile, photon B is held as a standard torpedo for 1 point of energy, and photon D is held as is for 2 points of energy. The player decides that the proximity fuze on torpedo C is inappropriate and decides to change it to a standard torpedo. This costs no energy but must be done during an Energy Allocation Phase (E4.34). The player also decides to fully overload the torpedo and (in the same phase) allocates 4 more points of warp power to it, in addition to the 1 point needed to hold the original standard load.

The total cost for the photons this turn is  $2.5+1+2+5=10.5$  points, 5 points of which must be warp energy. ♣♣♣





## STOP THE JINDARIANS!

These battleforces are designed to be used in Scenario (SL149) which was published in this issue. These forces could also be used in fleet duels.

### FEDERATION (Chuck Strong)

One DNa+ (211): 1 T-bomb (+4); drones: 1 type-IVM (+0.5), 1 type-IIIECMM (+1), and 2 ADD = 216.5.

Seven NCLa+ (868): Each 1 T-bomb (+28); drones: 1 type-IVM (+3.5), 1 type-IIIM-ECM drone (+7), and 2 ADD = 906.5.

Three POLa+ (147): Each drones: 1 type-IVM (+1.5), 1 type-IM (+1.5), 1 type-IIIM-ECM (+3) = 153.

One SC+ (124) = 124.

Total = 1400.

Exploit the retrograde. Since they must try to get past you and the maximum speed of their heavy ships is 21, this is an ideal situation to use the retrograde. Hold range 25 and fire 37 proximity photons and 59 usable phaser-1s every other turn. Then start armingphasers and photons on the next turn while holding phaser fire and using any extra power for ECM/EM. This allows for maximum ECCM during your turn of fire. Use scatter-packs to attack fighters, and use the large drones on the ships. Use the ECM drones for self protection.

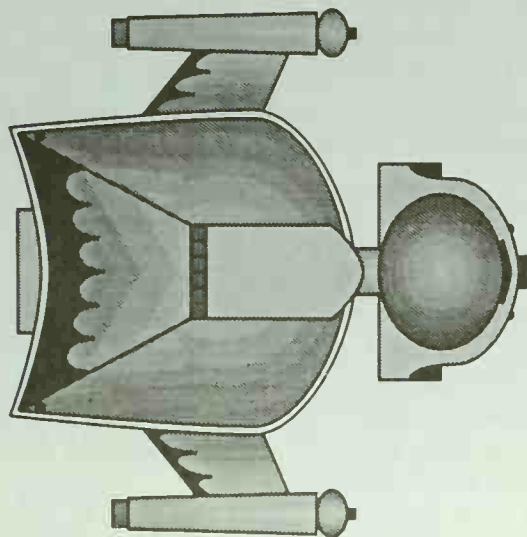

### KLINGON (John Wyszynski)

Three D7W (465): Each drones: 12 type-IM (+18) = 483.

Three D7K (393): Each Y175 refit (+12); drones: 8 type-IM (+12), 2 type-IVM (+3) = 420.

One D7AK (140): Y175 refit (+4), UIM refit (+5); drones: 4 type-IM (+2), 4 type-IVM (+2), 2 extra boarding parties (+1) = 154.

Three F5K (234): Each Y175 refit (+9), drones: 6 type-IM (+9) = 252

One F5SB (85): Y175 refit (+3), drones 6 type-IM (+3) = 91.

Total = 1400.

Use the superior speed and maneuverability of these ships to keep the Jindarians at 21 to 30 hexes range. By concentrating the disruptors of the seven D7s, it should be possible to eat into one of the Jindarian ships in a couple of turns. The F5s, along with the drones and phasers, should be used to protect against the Jindarian fighters and shuttles. The drones should also be used to tie up the rail guns in defensive mode. The SFG is intended to be a threat which will keep the Jindarians from getting spread out; which when combined with the rail guns in defensive mode makes shuttle/fighter operations that much more difficult. A successful SFG attack and follow up should end the battle (if the Jindarians allow it to happen.)

### ROMULAN "OLD GUARD" FORCE (Larry Lanning)

KE (140): 4 T-bombs (+16), MRS (+8), Praetor Team (+25), 4 extra boarding parties (+2), 2 Commando squads (+2) = 193.

Two KE (280): Each 4 T-bombs (+32), MRS (+16), 5 extra boarding parties (+5), 2 Commando squads (+4) = 337.

SER (113): 3 T-bombs (+12), 2 Commando squads (+2) = 119.

Two WER (206): Each 4 T-bombs (+32), 2 extra boarding parties (+2), and 2 Commando squads (+4) = 244.

FALR (91): 3 T-bombs (+12), 2 extra boarding parties (+1), 2 Commando squads (+2) = 106.

Two WHR (126): Each 2 T-bombs (+16), 4 extra deck crews (+4), 2 Commando squads (+4), fighters: 5 G-II (+70) = 220.

Two BHE (158): Each 2 T-bombs (+16), 2 extra deck crews (+2), 1 extra boarding party (+1), 2 Commando squads (+4) = 181.

Total = 1400.

This force has enough plasma-R torpedoes (five) in it to make even a Jindarian dreadnought think twice about a head-on attack. Like most of the first generation forces, this one is light on phaser power. Also, do not forget that each of these ships carries an NSM as standard equipment.

### NEW ROMULAN (Stephan Fassman)

Condor (234): 6 T-bombs (+24), 1 NSM (+8), 2 Commando squads (+2) = 268.

RoyalHawk-K (192): 4 T-bombs (+16), 1 NSM (+8), 2 Commando squads (+2) = 218.

SPA+ (135): 4 T-bombs (+16), 1 NSM (+8) = 159.

SPB+ (120): 4 T-bombs (+16), 1 NSM (+8), 4 extra deck crews (+2), fighters: 8 G-II (56), 8 G-SF (72) = 274.

Two SKEA (210): Each 2 T-bombs (+16), 1 NSM (+16) = 242.

Two SKA (204): Each 2 T-bombs (+16), 1 NSM (+16), 3 extra boarding parties (+3) = 239.

Total=1400.

This force has 2 plasma-R torpedoes, 4 plasma-S torpedoes, and 14 plasma-F torpedoes, not to mention the fighter plasmas. Every ship has a full load of T-bombs and an NSM. Note the Condor does not have the plasma-F torpedoes or phaser-3s of the plus refit.



**KZINTI** (John Wyszynski)

CCH (147): 2 Commando squads (+2); drones: 12 type-IM (+6), 4 type-IVM (+2) = 157.  
 CC (270): Each drones: 12 type-IM (+12), 4 type-IVM (+4) = 286.  
 Four BC (512): Each Y175 refit (+16); drones: 12 type-IM (+24), 4 type-IVM (+8) = 560.  
 Three DW (252): Each Y175 refit (+18); drones: 12 type-IM (+18), 4 type-IVM (+6) = 294.  
 DWS (90): Y175 refit (+6); drones: 8 type-IM (+4), 6 type-IVM (+3) = 103.  
 Total = 1400.

The design of this battle force is to maximize the number of long-ranged direct-fire weapons (disruptors) available. The Kzintis have little other choice, as drones are generally ineffective against the Jindarians.

**GORN** (Jeff Laikind)

CCH (171): MRS (+8), convert 2 boarding parties to commando squads (+1) = 180.  
 CV (120): 4 extra deck crews (+2); MRS (+8), fighters: 5 G-18 (+50), G-18E (+12), 6 G-10 (+60) = 252.  
 Two BDD+ (196) = 196.  
 CS (161). HDA (130). BDA (99). HDD+ (117). BDL+ (105). LSC+ (112) = 112.  
 Twelve T-bombs to be spread through the fleet (+48).  
 Total = 1400.

The Gorns, like the Romulans, are at a disadvantage against Jindarian ships. Arming cycles of the plasma torpedoes are three times as long as those for rail guns, and the torpedoes are subject to defensive rail-gun fire. It may be best to string out plasma launches to draw as much defensive fire as possible; the plasma-F torpedoes on the G-10s and shotgunned torps from the ships will help with this. Alternatively, massed plasma, particularly with the plasma-R torpedo, will guarantee that something will get through. If the Jindarian deploys swarms of shuttles, punish them with T-bombs. Altogether though, your phasers may be your only weapon that hurts their ships.

**THOLIAN** (Larry Lanning)

CVA (141): 4 T-bombs (+16); MRS (+8); 4 extra deck crews (+2); 2 extra boarding parties (+1); 2 Commando squads (+2); fighters: 11 Spider-II (+99), 11x Spider-III (+66), 2x Spider-E (+22) = 357.  
 CAP (128): 4 T-bombs (+16), replace Admin shuttle with GAS (+2), replace Admin shuttle with web anchor buoy (+8), 5 extra boarding parties (+2.5), 2 Heavy Weapons squads (+2), 2 Commando squads (+2), Tholian Prime Team (+25) = 185.5.  
 CA (128): 4 T-bombs (+16), replace Admin shuttle with GAS (+2), replace Admin shuttle with web anchor buoy (+8), 5 extra boarding parties (+2.5), 2 Heavy Weapons squads (+2), 2 Commando squads (+2) = 160.5.  
 Two DD (160): Each 2 T-bombs (+16), replace Admin shuttle with GAS (+4), 5 extra boarding parties (+5), 2 Heavy Weapons squads (+4), 2 Commando squads (+4) = 193.  
 Three PC+ (195): Each 2 T-bombs (+24), 2 extra boarding parties (+3), 2 Commando squads (+6) = 228.  
 Two PCA (154): Each 2 T-bombs (+16); 2 extra deck crews (+2), 2 Commando squads (+4) = 176.  
 SC (90): 2 T-bombs (+8), 2 Commando squads (+2) = 100.  
 Total = 1400.

Try to use your webs to stop the Jindarians. You might wish to transfer the web anchor buoy to the DDs and have them build the webs while the rest of the force slows the Jindarians down. There are enough boarding parties spread among the force to capture just about any of the Jindarian ships.

**HYDRAN** (Ken Burnside)

ID (205): MRS (+8); 4 extra deck crews (+2); fighters: 16 St-2 (+160), 6 Stinger-H (+60), 2 Stinger-E (+24) = 459.  
 DA+ (100): 6 Stinger-2 (+60) = 160.  
 Two AH (108) = 108.  
 Three RN+ (333): Each with 6 Stinger-2 (+180), 2 Stinger-H (+60), 1 Stinger-E (+36) = 609.  
 GEN+ (44): 2 Stinger-2 (+20) = 64.  
 Total = 1400.

If EW fighters are not used, this force gains a total of 10 BPV for Commander's Option items. This force relies on the range 10 firepower of the Hydran Stinger, of which this force has 59 total. Do not fire the hellbores in enveloping mode unless the Jindarian has his minimal shields up and you have just battered one of them down.

**ANDROMEDAN** (David Everett)

Intruder (265): 4 T-bombs (+16), 10 extra boarding parties (+5) = 286.  
 Two Mamba (260): Each 2 TBs (+16), 6 extra BPs (+6) = 282.  
 Infestor (258): 2 T-bombs (+8), 4 extra boarding parties (+2) = 268.  
 Two Mamba (260): Each 2 T-bombs (+16), 6 extra boarding parties (+6) = 282.  
 Three Cobra (249): Each 2 T-bombs (+24), 6 extra boarding parties (+9) = 282.  
 Total = 1400.

**LYRAN** (Stewart Frazier)

NCA (146): UIM refit (+5), MRS (+8) = 159.  
 CWLp (138): Power pack refit (+9), MRS (+8) = 155.  
 STJ+ (139): 4 boarding parties (+2) = 141.  
 Three CW+p (357): Each power pack refit (+27), UIM refit (+15) = 399.  
 DWLp (101): Power pack refit (+9), UIM refit (+5) = 115.  
 Two DW+p (186): Each power pack refit (+18), UIM refit (+10) = 214.  
 DWS+ (100): Power pack refit (+9) = 109.  
 27 T-bombs (+108) distributed among ships.  
 Total = 1400.

Retrograding would be best, as this force is "fragile". Lead with the STJ in any case, as it can absorb more damage.

**ISC** (Patrick Abram)

DN (280). Two CA (370). Three DD (276). Four FF (292). HSC (170).  
 12 points for T-bombs or extra boarding parties.  
 Total = 1400.

**FRAX** (Steven Petrick)

DN (210): 6 T-bombs (+24); 4 extra boarding parties (+2); drones: 6 type-IECMM ATG (+9), 9 type-IVM (+4.5); MRS (+8); drones for MRS: 1 type-IVM (+0.5), 5 type-IM (+2.5), 6 type-VIM (+1.5) = 262.  
 Two CA (280): Each 4 T-bombs (+32); drones: 3 type-IECMM ATG (+9), 1 type-IM (+1), 4 type-IVM (+4); MRS (+16); drones for MRS; 1 type-IVM (+1), 5 type-IM (+5), 6 type-VIM (+3) = 351.  
 Two CW (240): Each 4 T-bombs (+32); drones: 3 type-IECMM ATG (+9), 1 type-IM (+1), 4 type-IVM (+4) = 286.  
 Two DW (180): Each 2 T-bombs (+16); drones: 3 type-IECMM ATG (+9), 1 type-IM (+1), 4 type-IVM (+4) = 210.  
 Two FF (150): Each 2 T-bombs (+16); drones: 3 type-IECMM ATG (+9), 1 type-IM (+1), 4 type-IVM (+4) = 180.  
 DWS (100): 1 T-bomb (+4); drones: 3 type-IECMM ATG (+4.5), 1 type-IM (+0.5), 4 type-IVM (+2) = 111.  
 Total = 1400.





## BUILDING AN SFB GROUP

No aspect of the SFB hobby is as vital as the creation and maintenance of viable playing groups.

Having a group means, simply put, always having an SFB opponent. This means you will play the game more often, enjoy it more, and become better at it. Being in an established group can do even more for you. Because someone has to be the first to buy a new product, everyone else gets a chance to see it and decide if that's what they want. Because several people will, more or less at the same time, start using a new product, the group as a whole will find more interesting things in it than any single player can. With several players around, there will always be someone willing to try a new rule, ship, scenario, or tactic. If a rules question arises, someone will know the answer (or at least there will be a range of informed opinion).

There are two key elements to building a group: finding people to join and convincing them to keep coming.

### RECRUITING NEW MEMBERS

Everyone is always looking for new opponents, and a group is basically an organized system of opponent locating and matching. Here are some ideas.

- Notices in game stores. Most stores that sell wargames have a bulletin board where players can find opponents. Post an appropriate notice there. You can even include pre-cut little tear-off strips with the contact phone number in it. There may also be public bulletin boards (such as in the Student Union Building on a college campus) and even local computer bulletin boards. Important: When a new player calls in, the key point is to get him to come to the next meeting. Don't scare him off by trying to impress him with everything your club is into.

- Once your club is established, you might get the local radio and TV stations to announce it on their free community bulletin boards. (Not all newspapers and TV stations have these.) Look for opportunities to do something that would get the newspaper or a TV station to do a story about your group. This will bring gamers out of the woodwork!

- Send Task Force \$1 and a stamped self-addressed envelope, and they will send you a list of known Star Fleet Battles players in your area.

- Attend nearby conventions. Play in or run an SFB event at those conventions. Pass out invitations to your next club meeting. See about getting a small ad in the program.

- Write up a listing for Captain's Log. (This option is available only to established groups which are conducting at least some playtesting, but it's a good way to build up a group.)

- If there is a general gaming group in your area, go there and play SFB and try to attract more players.

- If there is a Star Trek or science fiction fan club in your area, go there with a copy of Cadet Training Manual or Star Fleet Missions and just start playing. You'll attract any gamers present, and perhaps even a few future gamers.

- Placing an ad in a local "advertising newspaper" is cheap but often produces more crank calls than gamers.

### FINDING A GROUP

It might not be necessary to create an SFB group at all. Maybe, just maybe, there is one near you. Finding the group is simply the reverse of the above procedures. (Obviously, this group is trying to recruit *you!*) If you don't know of a group, and try to start one only to be found by one, evaluate the situation (how big their group is and how big any group you have assembled is, common goals, personalities) and see how the two groups can best merge into one. If you are moving to a new area, buy the TFG player list for that area and start contacting the players in advance looking for a group to join.

### TRAINING NEW PLAYERS

While the preceding steps will help you find anyone who is already playing SFB, you should not rely only on that source. You need to train new players from scratch. This is a two-stage system, finding a candidate and training him (or her) to play the game.

There are two types of potential members for your club: gamers who haven't found SFB yet and non-gamers. Non-gamers who might prove interested in SFB can be found at science fiction clubs and conventions. Gamers are found where gamers gather (conventions, game clubs, game stores).

Once you find candidates, arrange to teach them SFB using one of the established methods (Cadet Training Manual, the fighter-PF-frigate-cruiser system used in Houston, the Kzinti frigates used in the southeast, or something you invent yourself). You might teach them in groups, one-on-one, at your club meetings, or in quieter individual sessions.

### RUNNING A GROUP

There is no single "correct" way to run an SFB group. There are dozens of successful ways, ranging from total anarchy to elected officers, military ranks, and Duke Roget's Rules of Order. Whatever works for your group, *works for your group*. If it works, do it some more. If it doesn't work, do something else.

The sum total of the fun that all members will get out of the group is equal to the sum total amount of work and preparation put in by the entire group. In practice, this means that a handful of club officers do all of the work while everyone else has a ball. The work load isn't all that heavy, but there are many dangers. Do not give a job to (or elect) someone who doesn't want it or who cannot or will not actually do the job. Divide the workload up on functional lines, rather than trying to make your club fit into the typical format of non-gaming clubs. Rotate jobs *before* the current officers burn out.

As the good book says, "Let he who would be your leader be your servant, and he who would be your servant be your leader." You aren't electing a president; you are hiring a club manager. (Said another way: You club officers were not elected to show your profiles and pronounce profound knowledge that all others must take as gospel. You were elected to arrange meetings so everyone else could have fun.) The leader does not decide that the club will meet at a certain day and time; he tries to find the best match between available meeting facilities and times people are available to meet. The leader does not decide that the club will now play the Captain's Game campaign; he lets the group decide what campaign will be played and then either runs it or finds someone responsible who will run it.

Whether you call them President and Vice, Chairman and Committeeman, Captain and Lieutenant, it comes down to:

- Activities Director: This person finds a meeting facility; collects enough dues to pay the deposit or rent (if any); gets there on time to sign the paperwork, unlock the door, and set up the chairs; and maybe chairs the business meeting. This officer should lead the group into selecting any activities (such as a campaign) but should never dictate to the group what those activities will be.

- Cruise Director: This person greets each member, guest, and visitor at the meeting door, then helps them find someone else who wants to do (today) the same sort of activity. This duty often rotates from meeting to meeting since the Cruise Director will have his own games interrupted by any new arrivals.

- The Training Officer is responsible for training anyone who wants to play SFB but does not do so currently, or at least talking some group member into doing so. This job is often combined with the Cruise Director. This is an important function, since new members are needed to replace those who inevitably leave to get married, go to school, move away, etc.



- **The Editor:** Every group needs a newsletter, and this is the person who runs it. More on this later.
- **The Bookie:** This is the person who keeps the records; maintains the mailing list; and (most sacred of all) maintains a file of errata, rules interpretations, rulings from ADB, and house rules. This function is often combined with the Editor.
- **Campaign Director:** If your group has one or more campaigns going on, each will have a director. The director makes the rules and sets the policy *for that campaign*. This is often the Activities Director.

### GROUP ADMINISTRATION

Try not to waste a whole lot of time on the mechanics of running a group. The best government for a club is the minimum to get the next newsletter mailed and the next meeting held. Try to avoid a lot of rules, by-laws, and so forth. If your "constitution" doesn't fit on one piece of paper, you don't need it.

Regular meetings are the first and most important function of a group. Everyone needs to know where his next SFB game will be played, and when, so that he can set aside the time for it. Announce this in the club newsletter and on your other promotional materials.

You'll have to have a "business meeting" during each gaming session. Hold this in the middle so people don't get the idea of arriving just late enough (or leaving just early enough) to avoid it. Keep it short. If people start to look bored, finish the current agenda item and get on to the next one. If you announce a club project and don't get wild applause, stop and ask them if they would really rather just forget that one. (You don't have to do everything you can think of.) If players start to hate the business meeting, change how you are doing it.

You shouldn't need a club treasury or bank account, and dues should be kept to a minimum. Handle newsletter subscriptions by having people pay for a few issues at a time or provide the Editor with stamped self-addressed envelopes. If the meeting room costs a few dollars, collect enough for the next meeting.

Avoid excluding people if you can. If someone is being obnoxious, have one mature club member take him aside and encourage him to be more sociable. If your group wants to have a minimum (or maximum) age rule, that's your business. But keep track of anyone who doesn't meet your requirements (or who doesn't live close enough, or who can't game on the day you do), and encourage all of them to form their own club. Meet them a couple of times a year for tournaments or a campaign, and exchange reports for your respective newsletters.

### BUILDING GROUP SPIRIT

Once you have found some SFB gamers and got them to a meeting, you have to have something to make them want to come back. That is what the "program" is all about. Here are some program ideas.

- Information not available elsewhere is a powerful reason for people to keep coming back. Be sure your club has a subscription to Starletter (now *Star Fleet Times*) and brings all back issues to the meeting. Anyone with a letter from ADB or something new from TFG should bring it. Try to encourage someone to get on GENIE and bring the latest rules updates, gossip, product schedules, and playtest ships and scenarios.
- **View new products:** Presumably, any new product (no matter what it is or where it came from) will be bought by someone in the club. Encourage everyone to bring the latest thing they have purchased and show it around. New and fringe members will find the ability to see new products before investing in them a definite plus.
- Attend a convention as a group (perhaps with club T-shirts), and even run an SFB event at the convention.

- **Club Challenge:** Locate another club within driving distance, and challenge them to a mini-tournament. This builds camaraderie, teaches new tactics, and establishes a network.
    - Buy one (or more) positions in a game of *Star Fleet Warlord*, and work out the orders for exploration and conquest as a group. You can even enter your club name as the corporation!
    - Design a scenario together, playtest it, and get it published, listing your group as the designer. (Warning: Be sure to ask ADB about the idea before spending time writing it up, and be sure to have ADB check the write-up before spending time playtesting it.) This can also be done with a ship design, but those are much harder to get ADB to publish.
    - Obtain some playtest materials and conduct a playtest project, asking for your members to be listed in a future SFB product under your group name.
    - Run a Tactics Board like those in *Captain's Log*. This can often be done during the mid-game pizza break.
    - Hold a gaming event at a local store or some other public place. (The mall in front of the game store can be very effective.) Check with the mall and the store to see what is required before you carry in tables and set up games.
    - Get the group together, write up a bunch of term papers, have someone check them against the published papers for duplications and someone else check them for rules problems, then send them to ADB in a group. When you get the reply, go through the reply as a group.
    - Have one member of the group (or a team) create a special scenario to use tactical intelligence. Each side only knows what it can discover. Other special scenarios can also be used.
    - Run a practice tournament, complete with judges and opponent matching and time limits, so players can prepare for competition at *Origins* or another event.
    - Once a year, have everyone fill out a card with their complete name, address, and phone number, and send this to ADB to be added to Starlist.
    - If a member is moving away, give him a going-away party, with a list of SFBers in his new home town (obtained from TFG) as a going-away present.
- And of course, the two final and most powerful means of building group spirit, a newsletter and a campaign, deserve their own write-ups.

### THE GROUP NEWSLETTER

The group should have a newsletter, even if it is only one page printed out on someone's home computer. The newsletter tells those who missed the last meeting what fun they missed, and tells them what fun they will have at the next meeting. Some of the material that should be included:

- Schedule of the next two meetings and activities.
- What happened at the last meeting. (Absolutely avoid printing long diatribes by some group members against others. Print articles about how you can all get along, not how you're at each other's throats. Never say anything bad about any store that is providing you with a meeting room.)
- Reviews of new products (or even scenarios within new products) written by club members.
- Information, errata, rumors, rules updates, and so forth.
- You could run a survey, but it's a lot easier to do that at the club meeting with a show of hands. Avoid anything that looks like accounting or tabulating. Reading survey replies is work; counting hands is easier.
- Encourage anyone with any artistic ability.
- Send a copy of your newsletter to ADB. You can get permission to reprint an SSD or scenario from one of the networks pretty much for the asking.
- A couple of good jokes couldn't hurt!



**RUNNING A CAMPAIGN**

One of the most fascinating activities for an SFB group is to run a campaign, since this will give the battles "a past and a future" and give the games an entirely different feel. No longer can you afford to let your own ships explode; you'll need them next time!

There are many kinds of campaigns that can be run, but a successful campaign must adhere to certain principles. It must be possible for the game to survive a given player not showing up for a given meeting. It must not exclude players (since they would then have no reason to show up). It must not involve so much work (by the players or the managers) that eventually it's not worth pursuing. And (most important) it must be something fun that provides a positive experience for those who participate. Here are a few ideas:

- The published campaigns (Captain's Game, Survey Captain's Game, Frigate Captain's Game, Tour des Klingonez) can be excellent. It will take several meetings to play the required games, so if a player misses a meeting, he can make it up the next time. (Allow a fixed number of make-up games, perhaps two or three.) The paperwork is minimal, and the design work is already done. About half of the club would play the Captains, while the rest would play the various monsters and other opponents. Those players who don't want to be tied down to the commitment of 10 games in 12 meetings can play the monsters.

- The PF Campaign Game can be a real barn-burner. Two players (one on each side) play the sector commanders. Other players take "temporary" positions playing in PF battles. Such battles are short, allowing time for other gaming at the same meeting. People might play a few meetings, then play something else for a meeting or two, and drift back into the game.

- Some groups play a simplified campaign (modeled on the PF campaign) in which a number of assorted ships (Coalition on one side, Alliance on the other) are assigned to a given sector. Numerous special events, produced by random die rolls, are provided on a table. When the meeting starts, any player who wants to participate that day (who may or may not have participated in earlier or later battles) is assigned a ship and sent to a given sector to meet a player from the other team. A random event is then rolled, and the scenario proceeds. This generates a wide range of battles, none of which are balanced. (That's the point of the special events, since each is structured to allow a smaller ship a chance to win.)

- The Star Fleet Defense Game can work, although it will take a lot of meetings and your group may lose interest before finishing it. Set up the scenarios; then assign ships to those players present and willing to play.

- Full production campaigns, with maps and economics and so forth, are often spoken of, but seldom done, and are successful even less often. They require too much paperwork, too many players, and assume that given commanders will always show up to play their race. Even so, there have been some notable successes, and you are welcome to try.

- The Star Fleet Warlord boardgame, to appear shortly, will provide yet another way to set up a campaign for your group.

**KEEPING THE GROUP HEALTHY**

Clubs meet various problems and challenges.

Any given club member will eventually leave (although it may take that member 10 years or more to do so) for any of a variety of reasons (marriage, divorce, school, new job, moved away, found another game, etc.). You need to minimize your losses, by making the club a good place to be, and maximize your recruitment of new members. If someone drops out, have someone call him every few months and remind him that the club is still there and he is still welcome. Every new member

should be encouraged to fill out a membership form (so the club officers can personally call him about the next meeting).

The worst danger is fragmentation, i.e., having the club split into two or three groups, none of which are large enough to survive the sudden departure of one or two members. If people want to play different things, encourage them to do so at the same meeting and to try each others' favorite scenario (or rule, or whatever) now and then. If most of the group is involved in a campaign (or playtesting, or something else), take a day off every few meetings and play some "pick up" battles that everyone can join in. If someone wants to use an optional rule and no one else does, promise him a specific future meeting when that rule will be used. If part of the group does spin off, keep in touch! Encourage them to visit your meetings and your members to visit theirs. Exchange information for the newsletter each group does, or publish a joint newsletter. Call them now and then and just chat, and see if you can come up with an activity both groups would enjoy.

Get someone to bring their camera and shoot a roll of film of a meeting, then put the pictures into an album. Be sure to list everyone in every picture, and even include a brief bio of them. Indeed, many clubs have a book listing each of their members, and each member lists his interests, experiences, things that got published, victories, and other accomplishments. Let new members read this book and see how much FUN they're going to have if they keep coming back.

Some groups have been gaming for a decade (the Houston SFB Association springs to mind) while others rise and fall every couple of years. If your group falls apart, and you are the last one there, don't just turn out the lights. Keep everything (newsletters, files, mailing lists) for the time that the group will rise from the ashes like a Phoenix. When (not if) you get a phone call from someone wanting to start a group, you'll already be on the way. ☺☺☺

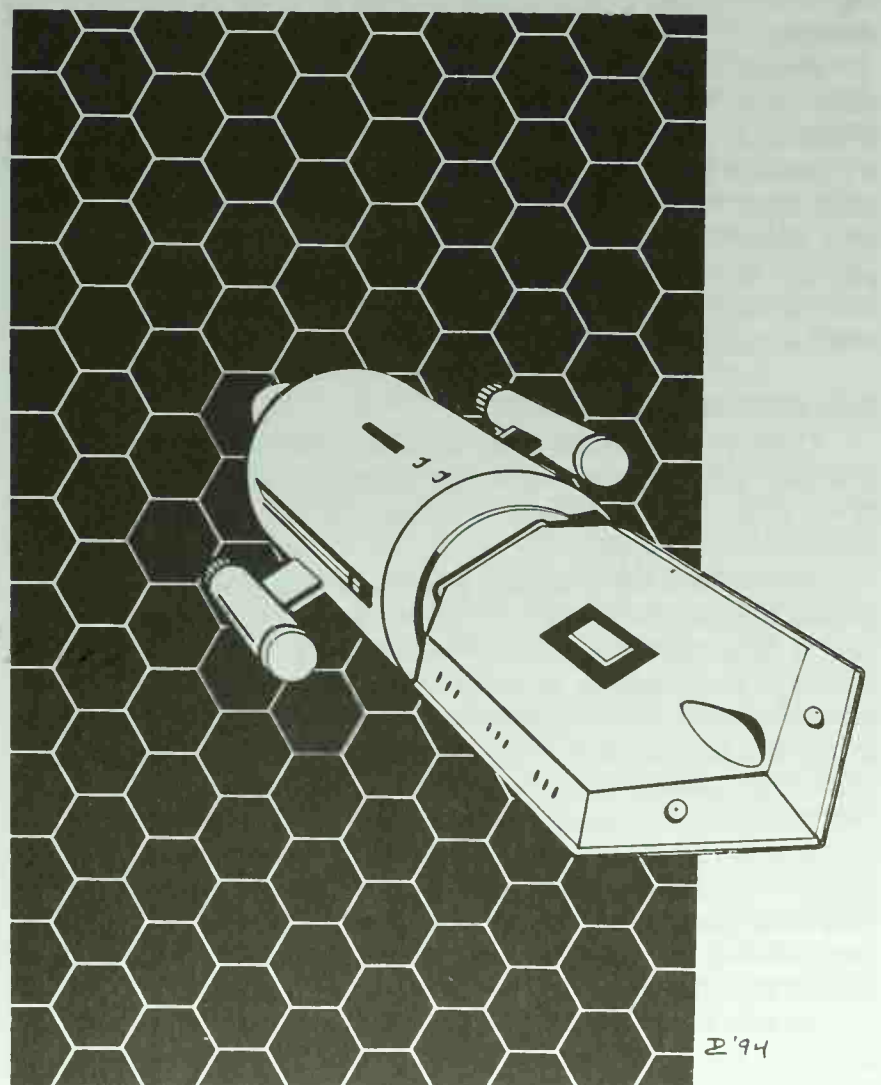



## 10 GOOD QUESTIONS

**1. My group is convinced that the BPV of a certain ship is wrong. What should we do?**

Write up a one-page letter citing the ship in question, what the current BPV is, what you think the BPV should be, and justify your position with comparative analyses with other ships and with playtest reports. Send this to ADB. We cannot change a BPV based on the input from one group, and we cannot even commit major playtest efforts without a similar statement from several different groups. But when we get several such reports on a given ship, we will assign staff playtesters to get to the bottom of the question and will correct the error if need be. Note that we cannot invest the time to resolve a case unless the putative error is at least 10% of the BPV.

**2. At Origins, I was adjudged the loser in my battle by a three-judge panel, but felt that the judges overlooked a particular fact that might have swayed their decision. What can I do since there is, by rule, no appeal beyond the three-judge panel?**

Well, the first thing is to insist that the judges resolve the battle by the procedure in Module T. Doing that will eliminate most of the problems. If you feel a key fact was overlooked, ask the judges on the spot if they took it into account (and be ready to answer the question, "Why didn't you bring this up before?"). Beyond that, everyone who loses an adjudication has the "right" to bend Steve Cole's ear on the matter (if he's there), but Steve can only order a review of the decision if you can clearly demonstrate that the Module T procedures were not followed.

What causes most of the complaints of this type is when, after the decision, someone asks one of the judges how the decision was made, and the judge, torn between the duty to be polite and the requirement not to discuss a case after it is decided, gives an off-hand comment that reflects only one of the factors on which the case was decided. The losing player, hearing this, may well believe that if that was the only basis for the decision, something might have been haywire.

**3. After years of saying "NO, NO, NO, NO, NO" to new races, why is ADB suddenly doing them?**

The answer is that the question itself is wrong in every regard. ADB never said "no"; it said "not until after Doomsday" which was finished with S2. The Jindarians have been in development for several years (based on submissions received in 1986; see page 16); the other races are just now entering playtesting, so there is no fear of having half-baked undeveloped races dumped into the game system (at least not from ADB).

**4. I have submitted several term papers, and two of them have been printed so far. I'm curious, however, because the papers I regarded as my best ones have not been published yet. How does the selection process work?**

When we get term papers, we immediately eliminate anything that is wrong, weak, doesn't work, or is a rules violation. We also eliminate anything we recognize as a repeat. The rest go into a huge file currently holding over 300 papers. When we get ready to do a Captain's Log, we pick out about twice as many papers as we have room for and send those to be graded. With 300 in the file, we cannot possibly go through them every time and select the best ones (besides, that would leave nothing for later issues), so we just take one from each "page" (which has about 5-7). Sometimes we pick one because it is short, on an interesting subject, or because we want to. If you have several papers on file, it's automatic that one will get into the pool. After that, the best papers in that pool get published and the rest are discarded or held over for later issues.

**5. I bought a tournament kit, but due to unforeseen circumstances the tournament never happened. What should I do? OR: Due to a comedy of errors, local judges bought two tournament kits for one event. What should we do with the second one?**

In either case, you can return it to TFG for a refund or you can use it at the next convention in your area. In the case of two kits, you might run a second event after the finals start for the first one. It wouldn't count for Rated Ace (there's a limit of one of ace event per convention), but it would keep people entertained.

**6. Do you have any advice on how to resolve disputes between highly competitive players going all-out to win?**

There are too many possible situations for more than general advice. Above all, remain calm yourself. Your decision must be made on the merits of the case, not on who is acting like a jerk or who is likely to start throwing things if he loses. If it is in patrol rounds, you can often resolve tough disputes by giving both players a win. In single-elim, you can give the loser a chance at a wild-card slot. There is rarely time to play the game over.

**7. Why does the name list provide only 64 Federation Police ships when the assignment data in the starbase and battlestation rules (based on the number of those bases on F&E) would seem to account for at least 86 and up to 146?**

We can't keep track of how many the Orions kill. Change your copy to read "and over 100 more", and it'll be fine.

**8. I heard about a new product called Star Fleet Journal. What's that about?**

It's an idea for a fiction product, format unknown, which we may do someday but isn't on the schedule. It would include scenarios and a variety of long and short fiction. The fiction from the old products might be added as "bonus" stories.

**9. Our group are big fans of X-ships. When will Module X2 appear? And will it have Second Generation X-ships?**

We don't know what will be in Module X2, although we have put several interesting proposals and memos in the file for that product. We have not yet made a decision on whether there will even be Second Generation X-ships in Doomsday, although we haven't ruled that out. Basically, don't expect this one until you hear from us about it.

**10. When will we see Module M: MARINES?**

When this issue of Captain's Log was written, the answer to this question was "We don't know because it takes 144 separate diagrams for the D16 Boarding Party system and that makes the product too expensive." As this issue was being proofread by Leanna and Tim, however, Steve Cole was explaining the problem to TFG President John Olsen over their monthly business lunch. No one knows what really happened, but Steve came back to the office with a new boarding party system drawn on napkins that works pretty much the same way, but only takes about 48 diagrams. (There are more "boxes" per "area" and the areas are divided by the "natural choke points" rather than arbitrary groups of 10 boxes.—SVC) If this revised system (which will be in playtest by the time you read this) works out, we might see Module M in 1995.

The D15 Ground Combat system, with its special planetary display map, is working just fine and will be in Module M.

Another decision that came from that same lunch was the Star Fleet Assault (the stand-alone ground combat system) was taken out of Module M and made into a separate product.

The staff and playtesters went over MO#2 and determined that there is a need for more commando ship SSDs. ☺☺☺



**101 WAYS TO KILL THE B10**

- #1: Tell the media it serves buttered popcorn on movie nights.
- #2: Tell the crew the popcorn is being replaced with healthy alfalfa sprouts.
- #3: Transport tribbles into the engine room.
- #4: Dare it to chase the *Millennium Pelican* through asteroids.
- #5: Tell the Klingon EPA that it runs on leaded dilithium.
- #6: Force the crew to read "The Kzinti in the Hat".
- #7: Schedule it for conversion to a mauler.
- #8: Have it built at a Yugo plant.
- #9: Tell Congress it is *Space Station Freedom*.
- #10: Flush all of the toilets at once while the Emperor is in the shower.
- #11: Tell the government it's carrying toxic waste.
- #12: Tell the DSF it's being assigned to the ISF to hunt pirates.
- #13: Tell the ISF that the helmsman is drunk.
- #14: Put Rush Limbaugh at the helm; he only turns right!
- #15: Attack it with 500 administrative shuttles.
- #16: Tell the Orions the crew consists of green slave women.
- #17: Forget to close the hatch when leaving spacedock.
- #18: Tell the captain he cannot raise the shields until the ship's counselor certifies that he's in touch with his inner self.
- #19: Tell Congress the drone racks exceed the magazine limit.
- #20: Challenge a Dominator to a duel, and neglect to prohibit it from bringing satellite ships.
- #21: Paint a female space dragon across the top of it.
- #22: Install X-technology and a positron flywheel.
- #23: Have Rodney King drive it through Los Angeles.
- #24: Start a rumor that the captain will go to war without approval from the council.
- #25: Tell the crew the movies are going to be replaced with episodes of "Webster".
- #26: Tell Oliver Stone the crew is conspiring against someone.
- #27: Have small mammals eat the eggs.
- #28: Assign construction to NASA.
- #29: Anchor it with six Gorn ships, and unload the plasma torps.
- #30: Paint "The Emperor wears bunny slippers" on it just before the annual Klinshai naval parade.
- #31: Name Conan O'Brien as the Public Affairs Officer.
- #32: Beam Madonna on board.
- #33: Tell the feminists that there are no female officers.
- #34: Get really lucky with photons.
- #35: Tell it battleships can ignore minefields.
- #36: Sent it alone to the Kzinti capital. It can handle it!
- #37: Tell the Conservatives that Hillary is the captain.
- #38: Let an ensign conduct unsupervised science experiments.
- #39: Put two B10s next to each other, and the gravitational stress will tear them both apart.
- #40: Make it the next site for Woodstock.
- #41: Assign it to carry oil exports from Planet Alyeska and provide the captain with plenty of booze.
- #42: Assign "Boom-Boom" Kilgore to the crew.
- #43: Tell the ESS there is a Federation spy on board.
- #44: Tell environmentalists it uses spotted owls for fuel.
- #45: Tell environmentalists that its movement kills dolphins.
- #46: Cancel the warranty.
- #47: Drop the Black Hole coverage from its insurance to save money.
- #48: Park a white Bronco in the shuttle bay; the reporters will rip the ship to bits trying to get at it.
- #49: Paint "this end forward" on both ends.
- #50: Remind the crew it was built by the lowest bidder.
- #51: Send the Kzinti version of a swarm at it.
- #52: Tell the Gorns that you can't build a B10 without breaking eggs. Lots of eggs.
- #53: Displace it into a planet.

- #54: Three squadrons of Stinger-2s should do it.
  - #55: Fifteen Hydran Cuirassiers did it just fine.
  - #56: Impound it for exceeding the warp speed limits.
  - #57: Tell the Seltorian Hive Ship that it's a Tholian colony.
  - #58: Paint it red and assign it as security for the *Enterprise*.
  - #59: Make it the site for the next Tailhook Party.
  - #60: Tell the Orions if they can steal it, they can keep it.
  - #61: Assign Ross Perot as navigator since he doesn't know where he's going.
  - #62: Tell the captain that the B10 CAN land on planets. Even on gas giants.
  - #63: Challenge the captain to a game of "chicken" without mentioning that you are on a planet.
  - #64: Park it in New York City without "the Klub", and it should be up on blocks with the engines missing in 24 hours.
  - #65: Forget to allocate energy for life support.
  - #66: Open the spacecocks and let the vacuum in.
  - #67: Tell the Romulans and Orions it can see cloaked ships.
  - #68: Get it wet. The rivets put in by penal workers will rust.
  - #69: Fit it with 8 R-torps; the shock should take care of things.
  - #70: Tell the captain to run it through a super nova to clean the space barnacles off of the hull.
  - #71: Tell the Organians it is designed to attack someone. It doesn't really matter who you tell them is the target.
  - #72: Put it on the defense budget, and let Congress vote on it.
  - #73: Put Kbill Clinton in command.
  - #74: Tell Congress it is an "assault weapon".
  - #75: Tell the Klingons it is scheduled to be converted into a Galactic Peace Monument, and they'll kill it themselves.
  - #76: Add a high-resolution camera, and send it to Mars.
  - #77: Go mano-a-mano with a Juggernaut.
  - #78: Put it in orbit around Jupiter with an obelisk.
  - #79: Upgrade the computer to Windows 3.1; it will crash.
  - #80: Name Roseanne Karr as morale officer.
  - #81: Play Barry Manilow on the intercom, and watch the crew fall asleep.
  - #82: Play hard rock on the intercom, and it will shake apart.
  - #83: Win three tournaments with it, and let the judges know.
  - #84: Take the "do not touch" sign off of the self-destruct switch.
  - #85: Tell the captain you can disarm the wild SWAC before he pulls it into the bay.
  - #86: Use it as the flagship of the attack on Tholia.
  - #87: Use it as the flagship of the attack on the WYNs.
  - #88: Assign Dr Kevorkian as the chief medical officer.
  - #89: Park it between two Tholians near a web caster.
  - #90: Convert the Security Stations into Bowling Alleys.
  - #91: Assign it as the studio for "KDSF Blue".
  - #92: Tell the Federation it is not politically correct.
  - #93: Tell the Lyrans it's a Kzinti ship.
  - #94: Tell the Kzintis that the Klingons are going to send it to the Lyrans to copy.
  - #95: Tell the Seltorians the Tholians are using it.
  - #96: Tell the Tholians the Seltorians are using it.
  - #97: Wreck the shuttles so it cannot launch a wild weasel.
  - #98: Tell the French it belongs to Greenpeace.
  - #99: Hire Tim "the Toolman" Taylor as chief engineer.
  - #100: Replace the central computer with a 486.
  - #101: Dare it to do three HETs in a row.
- Steve Cole, Steve Petrick, Bruce Graw, Tony Zbaraschuk, Scott Fridenberg, Dave Everett, Reece Watkins, D Jannke, Jeff Zellerkraut, Mike Mitchell, Ken Cole, Joe Stevenson, Erick Jimmerson, David Jensen, David Brinson, Bob Tweedy, Jeff Laikind, Keith Velleux, Jeff Guthridge, Rich Haas, Clay Wrobel, Spencer Cocherl, Rodney Reineke, Joe Butler, Markus Christopher, Jerry Bookter, Charles Davis, Larry Ramey, B Cipponeri, W Carpenito. We are accepting ideas for more (and perhaps funnier) humor sections for future issues.



**A NEW RACE: THE VUDAR**



*By Jon Cleaves*

The Vudar are a humanoid race, taller and thinner than Terrans with oversized eyes and a pale green complexion. Rather than evolving from primates, they are descended from a line of gecko-like reptiles. Their eyes have a clear inner eyelid which affords them protection while swimming. This eyelid also allows them to 'wet' their lenses without seeming to blink. This gives the offworlder the impression that they are always 'staring at you'.

Although descended from carnivores, the Vudar are generally peaceful and academic. They rival the Vulcans for their scientific achievements, and their products are a prized commodity in the Klingon Empire (of which Vudar spent more than a century as a subject world, producing 10% of the Empire's impulse engines). The Vudar rarely, however, serve on Klingon starships due to their need for ionizing radiation that would be hazardous for the remainder of the crew.

Vudar is located in the southernmost part of the Klingon Empire, right up against the galactic barrier. A 'weakness' in this barrier (called 'The Hole') allows some dangerous ionizing radiation to 'leak' into the space around Vudar. Although Vudar's atmosphere protects the planet itself (albeit not to a level comfortable for a Klingon occupation force), Vudar scientists were forced to develop several defensive technologies before they could begin serious space travel. Because of this, the Vudar are the galaxy's foremost experts on ion and impulse technology (or at least *they* think so).

'The Hole' also allowed the Vudar to hide the construction of a fleet that would otherwise have attracted the early attention of their Klingon masters. (The Klingons had authorized the Vudar to build small numbers of "police" ships for local convoy escorts, relieving the ISF in their sector. The Klingons could not tell how many ships were in service because of ion interference with their long-range scans.) This fleet, along with the development of a device that produces an artificial ion storm, provided the Vudar with the means to gain their independence from the

Empire in Y178. In the next seven years, the Vudar took advantage of the General War and carved out an Enclave for themselves from Klingon and Hydran territory along the galactic rim. The Vudar are scheduled for inclusion in a new Star Fleet Battles product (Module F2) in 1995.

Vudar Characteristics (Storm Team members)				
STR - 3	SPD - 3	LGC - 4	DIS - 3	GKN - 3
ACC - 4	LDR - 2	INT - 2	TEC - 3	PER - 5

The Vudar equivalent of Prime Teams are called Storm Teams. Vudar Storm Teams are developed in a manner similar to Federation characters. The Vudar Enclave Military uses the same divisions as Star Fleet. Storm Teams perform the same missions as Prime Teams, although they have few opportunities for "first contact" missions. They do land on planetoids to set up small Ion Storm Generators to cover the construction of larger ISGs used in making the system uninhabitable to other races.

Storm Teams usually contain the following members:

- Commander
- Emplacer (Engineer)
- Heavy Weapons Specialist
- Penetrator (Scout)
- Medic or Doctor
- Scientist

An Emplacer is a highly trained engineer, with a thorough grounding in ion technology. He is responsible for the correct installment and operation of the Ion Storm Generator the team is carrying. (Note: This ISG is a smaller semi-portable version designed only to protect the planetoid selected for installation of the much larger area-defense ISG system.)

A Penetrator is a special type of scout character whose mission is to get the team into whatever area/facility has been targeted for emplacement. He will have an abundance of skills in security procedures and systems as well as sensor systems.

Since the target area usually does not WANT an ISG to be emplaced, Storm Teams will almost always include a Medic and a Heavy Weapons Marine.

Storm Teams did not include Science division officers early in their history as exploration missions were performed by teams of scientists AFTER the target area/world had been grabbed. This was changed after the Vudar began expanding out of their immediate area and found a need for on-site analysis of terrain features and lifeforms. A small number of the scientists are "Non-Vulcan Psionicists".

Vudar Characteristics (Naval Personnel)				
STR - 2	SPD - 2	LGC - 3	DIS - 2	GKN - 2
ACC - 3	LDR - 1	INT - 2	TEC - 2	PER - 4

**THE ION RIFLE: THE VUDAR WEAPON**

Ion Rifle: BR# = 7 (BR# = 12 For non-Vudar characters.)

The Ion Rifle is a natural extension of the Vudar's extraordinary affinity for ion technology. This single setting rifle fires a deadly stream of highly ionized particles against a single target. If the target has no Energy AR, the D#s of the rifle's attack are resolved at a flat +2.

Pt Blank	Normal	Moderate	Long	Extreme
4m	5-250m	251-500m	501-800m	801-1200m

Vudar Ion Rifle (5kg)	6pp (600)
Lethal - 2 4/6/8	(12)



## THREE NEW VARIANTS

### PRIME TEAMS IN STAR FLEET MISSIONS

Each player starts the game with FIVE Prime Teams. These Teams are specially trained in all facets of individual action, including negotiation, combat, science, engineering, and medicine. A player can add one Prime Team to any ship, adding two points to one of the factors for that Mission. No more than one team can be used on any Mission. After it completes that one Mission, the team will go on R&R until the end of the game. Use any convenient token (pennies, paper clips) to represent your Prime Teams.

### STAR FLEET WARLORD

In this variant, you ignore the Missions deck. There are only three kinds of Missions, each involving the exploration and exploitation of a sector of the Greater Magellanic Cloud.

To determine what kind of sector you are exploring for each Mission (and hence, how to win that Mission), toss two coins.

**BOTH HEADS:** Wild sector, unoccupied. Send TWO ships. Use the CARGO rating of one ship and the SCIENCE rating of the other. (Alternate, die roll of 3-4-5.)

**ONE HEADS, ONE TAILS:** Home Sector for another corporation already engaged in exploiting it. For this Mission, send THREE ships. Add the COMBAT factors of 2 of the ships and the CARGO factor of the third. (Alternate, 2, 6-7-8, 12.)

**BOTH TAILS:** Disputed sector. Other corporations are already in this unoccupied sector trying to exploit it. Send THREE ships. Use the COMBAT or DIPLOMACY rating of the first ship, the SCIENCE or MARINES rating of the second, and the CARGO rating of the third. (Alternate, die roll 9-10-11).

### BLIND MISSIONS

The player who reads the card does so silently, not telling anyone else what it says except the number of ships to be sent. He does not send any ships on that Mission. After everyone has played their ship cards face down, the player holding the Mission card reads it aloud. Each player then has the option to withdraw all of his ships (i.e., put them back in his hand), BUT no player can look at the ships he has played before making that decision. After any players who wish to withdraw do so, the remaining players expose their cards and resolve the Mission as per its victory conditions. ★★★

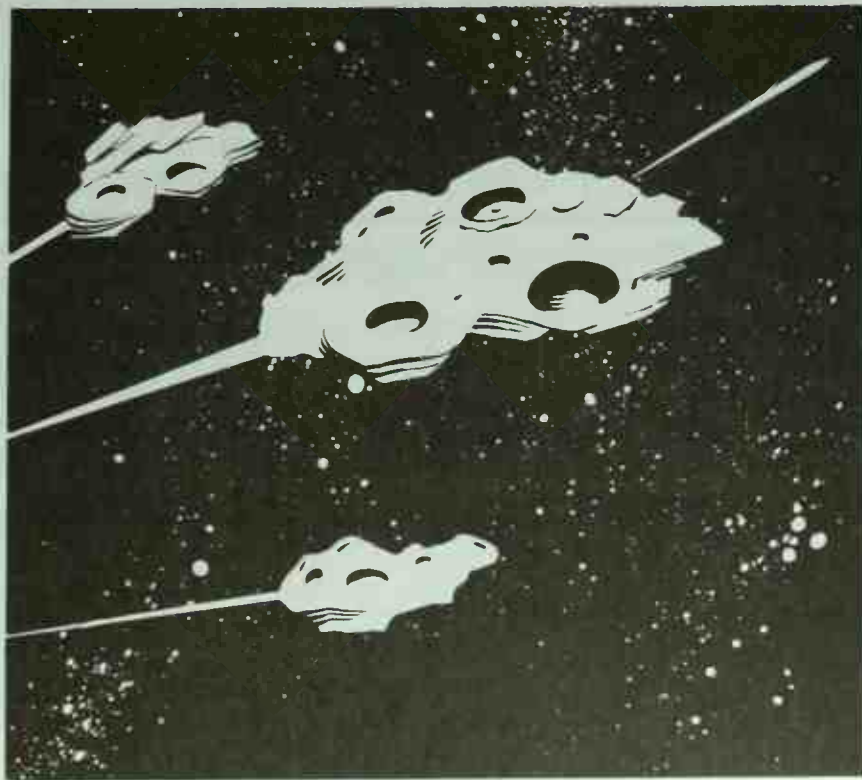

## FIVE NEW MISSIONS

### MISSION: STOP THE JINDARIANS!

A caravan of Jindarian asteroid ships is in the Neutral Zone trying to enter your space!

Each player sends THREE ships to stop the Jindarians at the border. Use the total COMBAT ratings of the ships. You can, if you wish, substitute the MARINE or SCIENCE rating of ONE of the three ships for its COMBAT rating.

The winner of this Mission is the player with the highest total of the factors listed. However, there is also a LOSER to this Mission. Whichever player has the LOWEST total LOSES one of his Mission victories; the card is taken from his victory stack and placed in the unused portion of the Missions deck. If he has no victories to date, there is no effect. If he only has a multiple victory card, exchange it with another player for an equivalent number of Mission victories (i.e., you only lose one Mission victory, not one card).

In the event of a TIE between the lowest totals, each can send one ship to reinforce his defense force. This will, in all probability, result in both players increasing their total to such an extent that some other player or players will become the lowest (and lose the Mission!). The Jindarians always take the path of least resistance in their wanderings, even if it's not fair to a force that didn't get to send reinforcements.

### MISSION: ALL-OUT WAR

Each player draws THREE additional Ship cards from the deck, then forms a fleet of FIVE ships. Three of the ships use their COMBAT ratings. The fourth can use its MARINES or COMBAT rating. The fifth can use its SCIENCE or COMBAT rating. The remaining ships in your hand can be used to reinforce this squadron to break ties. However, all reinforcing ships can use ANY one of their factors to add to the total.

This Mission counts as TWO VICTORIES!

### MISSION: X-TECHNOLOGY

A foreign power has developed the new X-technology, but has only been able to field a single prototype so far. You are to send a squadron of TWO ships to study this prototype as it conducts wargames in the Neutral Zone. One ship uses its COMBAT rating; the other can use either its SCIENCE (study it) or MARINES (capture it) rating. The winner is the highest total.

### PEACEKEEPING AND PLANET BUILDING

The planet Hispanola is governed by a ruthless regime that is, in every sense, a bunch of gangsters. They are ignoring the proper business of government in order to loot and terrorize their own people. This must stop (if only because the tri-video images on the commercial channels are too shocking for your taxpayers to endure).

Send a force of THREE ships. One will use its COMBAT factor to blockade the planet. The second will use its DIPLOMACY factor to convince the government to leave. The third will use its CARGO factor to bring in relief supplies for the starving Hispanolans. All three will ALSO contribute their MARINES factor when all of the above fails and they have to actually land troops and overthrow the gangsters.

### THE EXPORT SHIPS MARKET

A rich neutral planet is seeking to buy ships for its defense forces. You are to send TWO ships to demonstrate the superior technology you have for sale. Total ALL of the factors on BOTH ships! Highest total wins the contract! ★★★



## WARLORD!

Star Fleet Warlord, or SFW for short, is a play-by-mail strategy game set in the far future of the Star Fleet Universe, as part of a tri-video series in which Galactic Corporations vie for control of the Greater Magellanic Cloud. You begin with about 500 economic points and one planet. Your goal is to be the first to conquer 80 of the 1000 or so worlds or 7 of the 100 sectors in the mini-galaxy. With up to 49 other players all trying to do the same thing, this is not as easy as it sounds! The ships of Star Fleet Battles are used in the campaign, but combat is entirely handled by the computer, and game turns are processed every two weeks like clockwork. Customized games with different turn lengths (three-week or one-week) are also available, as are specially-sized games tailored to fit your gaming group.

Star Fleet Warlord is a totally computerized play-by-mail system operated by Agents of Gaming. For a complete rulebook with no obligation to play, send \$5 (US funds only) to Agents of Gaming, P.O. Box 31571, Dayton OH 45437-0571. Overseas customers send \$10. If you'd like more information, you can also call AoG at (513) 233-6886 (voice or fax) or Email B.GRAW1 on GEnie, or B.GRAW1@genie.geis.com by Internet.

### QUICK NEWS

**Turns By Electronic Mail:** Agents of Gaming now accepts Star Fleet Warlord turns sent by electronic mail! The GEnie network is used for this purpose (for more information on reaching GEnie, see the Database section of this Captain's Log). A computer program called the Warlord's Aide is available through GEnie which will allow you to input your turn and generate a file suitable for uploading to our GEnie account. The Aide will check your moves and orders for errors and can also print out an orders sheet for your permanent records. The Aide is provided free of charge (other than download time) to SFW players, and turns submitted via GEnie won't cost you a penny more than they would if you mailed them in.

### VICTORY REPORTS

A number of games concluded in the past few months, and the various winners were asked what they could tell us about how they won—the secrets of their success, if you will, put into their own words.

**Chris Naughton** (Zylon Death Fleet, winner of game #17 with 7 sectors, Canadian): "This was my first game, so I didn't know any of the new orders or special tactics. I expanded quickly and conquered two sectors while prospecting my home and most of the adjacent sectors. Agreements were made to keep the conquered sectors while sacrificing other, less critical areas. My biggest neighbor then attacked me. I retaliated with a quick strike to his Home Office. My fleet was kept off his base map until I was ready to go straight for the HO, which he had left poorly defended. He owned a lot of territory that I proceeded to conquer and win the game with. I continue to play in two games and am joining a third, so watch out!"

**Matt Smyth** (Catnip Inc., winner of game #21 with 7 sectors): "If I learned anything from this victory, it's the following three points. (1) Know when and who to attack. This comes mostly with experience, but keeping a close eye on the stock chart and your battle reports will help, and talking to other players will tell you even more. (2) Stick to your alliance. I doubt I could have won without the firm, solid alliance I formed early in the game. It gave me a secure border. If I had tried the backstab and failed, the resulting battle would have kept me from winning. (3) Let the fur fly! If someone refuses to deal with you or is in your way, run straight into him. Don't be afraid to go to war when you have to. Take the offensive. If you don't, someone else will!"

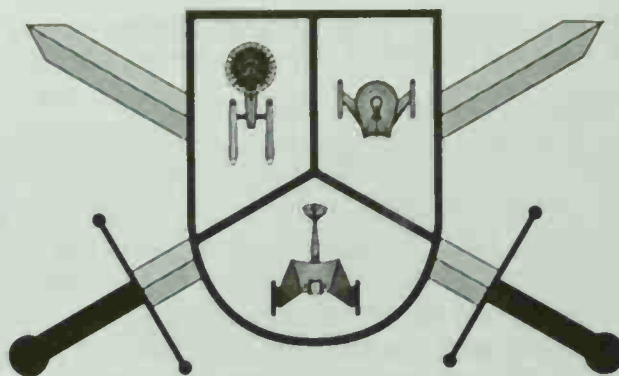

**Robert Vandenberg** (Krasnya Flot, winner of game #18 with 81 sites): "The Shadow (88) Corp and I made a strong alliance around turn 5, and we resolved to play together for one of us to win. Around the same time, I made a 'no-conflict' deal with Rogues Inc (209) which allowed rapid growth from the northwest to southeast. On turn 20, Shadow and I worried that Nasty Space Diseases (863) was coming on quick, and we agreed that I should take 10 of his sites to put me immediately over the edge. As insurance, I hit Sovietsky Voeny Flot (334) and Schlachthof Dreizhen (134), which was a good thing, as those sites were enough to hold on for a close victory."

**Bruce Spears** (D's Demonic Psychos, winner of game #19 with 102 sites, and Galactic Toxicology, winner of game #20 with 7 sectors): "The 'secret to my success' is one word: *diplomacy!* Most people do some diplomacy, but I doubt that many do it to the level that I do. Also, there are a lot of backstabbers out there; my record is clearly that I do exactly as I say and do not bend the truth—you know if I'm your friend or foe fairly quickly (once I decide). As a result, I don't think that I've made many enemies. This in turn means that most people don't begrudge me winning and don't make all-out efforts to prevent it. This in itself goes a long way, especially at the end of the game. I go out of my way to help out new players and get in good with them from the ground up—it pays off in future games, as these rookies turn into strong allies. Information is KING, once the skill levels of players are close (almost everyone is equal after a couple of games except the few totally clueless players that I've encountered), and good diplomacy breeds a good information-gathering network. I don't propose that I'm any more skilled than anyone else, just that I've diplomacized more successfully and had the opportunity to work with some interesting (and crafty) people in the process."

**Robert Vandenberg** (Mrachne More Flot, winner of game #22 with 86 sites): "Game #22 was unusual because very few Corps adjacent to me had phone numbers turned ON, and I prefer diplomacy by phone. I only made two deals, and those were late in the game and involved Corps two or three sectors away. Additionally, as this was an 'all-NPC' game, I was able to move farther and faster than I did in game #18. Game #22 was decided for me during turns 12 through 14. On turn 11, three fleets were nearly adjacent to an NPC Home Office in hex 71-1009. Potatoe Heads (617) had arrived first, conquered the HO, and fortified the site, but Magellanic Defenders (720) and I were close by. I destroyed the Potatoe Heads force and conquered 71-1009, but was badly damaged in the process. Magellanic Defenders then attacked while my shields were still down, but did not have enough attack factor and bounced. On the same turn he destroyed Potatoe Heads' Home Office in sector 61, removing that Corporation as a threat. Knowing I couldn't hold my position on 71-1009, I retreated long enough to repair and reinforce my fleet, correctly guessing that Magellanic Defenders would attack the site again. When he did, I caught and destroyed his fleet, conquering the site for good. With that fleet knocked out and Potatoe Heads out of the game, I had no close threats and was able to win the game a few turns later." ★★★



## WARLORD NOTES

### INSTANT FLEET REPAIRS *by Dan O'Connor*

Battles at Home Offices are often intense and deadly, and if the attacker wins, he often finds his surviving ships damaged and without shields. It is possible to fully repair this damage, even if your ships have no movement left after the attack! Just assign a Legendary Engineer to the site in your Miscellaneous Orders (assuming you do not have Reversed Orders ON). If you win the battle and take the site, the Engineer will automatically fix every ship in the hex that needs repairs. Of course, you must have the Engineer available, the resources to assign him, and the Ores in stock so that he can do his work. However, your fully repaired fleet will stand a much better chance of repulsing a counterattack.

*Voted the best Warlord Note this issue. Note that this tactic is possible because (unlike fortifications) you are allowed to assign an officer to the site the same turn you capture it.*

### FREE REPAIR POINTS *by Neil Chochrek*

The Orion Slaver is the only integration ship that is also a generic variant. This is an advantage when the ship is placed in the "R" (repair) mission because, if all the repair points are used up, they are easily replaced. This is accomplished by changing to another mission (it does not matter which) then back to the "R" mission. All the repair points will then be returned to maximum. Note that the switch does not have to be on consecutive pulses or even on the same turn, and is much easier than running to a base, repair planetoid or molten ores hex.

*GM's comment: This works just as well with any generic ship traveling with or near an integration ship.*

### REPAIRING DAMAGE *by Kelly Lofgren*

Always repair light damage as soon as you can. The cost is only 10% of the ship's base EP value in Ores resources, but if you don't fix it, the ship's AF and DF are reduced by a whopping 33%! (Apparently this was intended as a simulation of the way damage works in Star Fleet Battles—ships can lose multiple weapons in even a small volley of internal damage.) No other damage level causes this severe a decrease in effectiveness.

### PRIME TEAMS IN THE GRAVEYARD *by Jim Christensen*

Prime Teams (PTs) are the ultimate Graveyard of Ships enhancement. (The Graveyard is a special sector full of sites and prospecting, but you can only send one ship there the whole game.) No ship in the Graveyard should be without a PT. With one, your ship can train itself up to level 7 to maximize prospecting bonuses and safely enter most terrains. You earn the survey bonus too, since the PT makes your ship into an "N" variant. The Lyran Survey Cruiser is a fantastic Graveyard/PT choice. Not only is it huge, but it is also a generic ship, and the Prime Team lets it change missions at will!

### FASTER THAN THE ANDROS *by Tony Zbaraschuk*

The Andros have incredible movement capabilities, but there is a faster way to shift power from one theater to another, and it doesn't even need starbases. Simply switch several mission-capable ("G"-variant) ships to the PF ("P") or carrier ("V" or "K") missions, load them up, and use them as needed. When you have defeated your enemies there, or need the firepower elsewhere, switch them to other missions. The PFs and fighters will return to your main stockpile, and can then be immediately loaded onto PF tenders or carriers elsewhere (ideally, more "G" ships so that you can repeat this trick as necessary). You will need either bases (although not necessarily starbases) or a combination of integration ("I") and facility ("F") ships to pull this off, but the flexibility gained is more than worth it! ★★★

## VOLUNTEERS

*by Brian Woodring*

I took scouts because it's the only ship you have to volunteer twice for. Everyone has to be a volunteer to come to the Greater Magellanic Cloud to begin with, and only scouts require volunteers once you get here.

Now don't get me wrong, I don't mind the double hazard-duty pay, but that's not the sole reason for being in scouts. It's got the glamour of Ancient Earth aircraft fighter-pilots. You are elite — the best, most daring individuals anywhere. Sure, combat ship crews will tell you there's nothing better than going toe-to-toe with a heavy cruiser in your home space, knowing if you fail, the base will be undefended. But who do you think spotted that cruiser in the first place, hmmm?

On our first mission we headed west to the nearest of our unexplored borders in the HCS *Goodwind*, a heavily modified Hydran scout frigate. Primus Base gave us good scans of our sector but couldn't see any farther. As we traveled, Science Officer Krotag ran us through a series of drills to get us familiar with working under crisis. After a week of this, most of the crew wanted to shove him out the airlock. (I now truly believe he was, as he so often claimed, part of the legendary Klingon Pathfinders during the Trade Wars.) We were definitely ready to meet anything.

I was almost right.

Border crossing is the most dangerous and vulnerable time for us. With no reference points or map of dangerous territory, a journey could be cut very short by running into a supernova or exploding against a variable pulsar. Unlike the Milky Way, we don't have a complete map of the galaxy to tell us where these things are. We were lucky, not only for Krotag's training, but also for having Navigator Cartwright aboard. Her ability to "see" deadly terrain was uncanny. So, when we finally passed our borders into "undiscovered country", it was clear space all around.

After about a day of cautious travel, we had encountered nothing, so Captain Thaddeus called for all stop. Krotag yelled, "You, get down to Stellar Cartography. Cartwright, start recalibrating the sensors." The next five days were a blur of activity. My section of SC was in charge of mapping asteroid fields and dust clouds within our sensor range. I think there were five asteroid fields and at least two large dust clouds, but I can't remember exactly. While we monopolized the gravitic sensors, Krotag personally led Navigation in checking for any warp signatures in the area. All the scanning sections were almost finished with their projects when Krotag came onto the bridge.

"Listen up!" he barked. "I've been saving this until now. I didn't want anybody going coward on me when there was work to be done! We've scanned a strong warp signature just under a light year from here. There's enough information to send back to Primus Base. Now DON'T go whining about putting your lives in jeopardy over this data! If you can't handle danger, you know where the airlock is." That Krotag, he always knew how to motivate us!

He turned to Cartwright. "If you want to live to see another day, turn this tub around and get us out of here—NOW!" We hit high warp so fast, some of the crew almost got whiplash. When we returned to that sector (at a different point, mind you), we picked up a few battle reports on the Corporation News Network, and one of them was of great interest to us. It turned out our contact was gone—eaten by a Space Dragon, which had been eyeing us as dessert! We had gotten away just in time.

When I went back into the Cloud again after a little R&R from that first tour of duty, I volunteered for another scout. And never again will I fly anything but a scout. ★★★



## USING YOUR SCOUTS

by Bruce Graw

Scouts are some of your most important ships at the start of the game. A "scout" is any ship capable of scanning the terrain in an unexplored sector, thereby earning you a map of that sector. Having a sector map enables you to expand into new territory, allowing you to conquer or raid sites and prospect valuable areas. No Corporation can possibly expect to win the game without scanning at least six sectors during play, and usually several more than that.

Most scouts are found on the Ship List, marked with an "S" (scout), "Y" (survey), or "Z" (heavy scout) variant letter. However, don't forget that generic ships ("G" variants, such as tugs and Orions) can become scouts by changing to the "S" mission. You can also make *any* ship into a scout by placing a Legendary Science Officer (or Legendary Captain) aboard.

At the beginning of the game, most players purchase the H-SC and D-PSC ships during their initial build. These are the cheapest "true" scouts available, each costing a mere 60 EPs. Another popular choice is the C-FEL, which has the added advantage of being an exploration ship ("E" variant) as well, protecting it from deadly terrain. The O-SLV also makes a good scout as it can change its own mission (the only ship capable of doing this) to "S" and then change it to something else once a scan has been made. Other popular generic ships which can become scouts include the O-FT (which is speed-6), O-LR, W-AC and other WYN auxiliaries.

When the game begins, take a look at your map and determine the quickest paths to get your scouts out of your home sector. It will not be possible to get out of the sector on the first turn's move, since all Home Offices are at least six hexes from the border (something to remember when checking out an opponent's home sector map, by the way). You should make getting scouts off the nearest edges your first priority. If your Home Office is only six hexes from one of the edges, use your C-FEL or a scout with a Legendary Navigator to enter that sector. As the closest sector to your HO, you will want this to be your primary target for expansion.

You also want to send at least two other scouts towards other adjacent sectors, preferably three. (Don't worry about diagonally adjacent sectors just yet.) You want to get three sector scans on Turn #3 if you can, #4 if possible. If you lose a scout to a monster or nasty terrain, or have to move one because it lands in a nebula or other scan-blocking regions, don't worry about it. The same thing is probably happening to your competitors.

When you build ships on turns 1 and 2, be sure to purchase at least one or two more scouts. Buy one at your Warp Gate, which should be moving towards your most distant border. These scouts are your backups, taking the place of any destroyed scouts, or moving into the diagonal sectors if you got lucky and didn't lose any of your first "scout wave". You might consider spending the resources to build a BATS at your Home Office and place a Legendary Science Officer there, using the Starbase Order this provides to Scan Hex a safe spot along the diagonal. If another player is located there, getting a scan of his sector before he scans yours provides you with a diplomatic edge in any negotiations. (Of course, the reverse is also true, so be sure to watch your own diagonals, which is where players are *usually* located.)

Scouts can also be useful in the middle game. After they've scanned their initial sectors, keep your scouts moving outwards. Don't be tempted to use them to prospect—other, cheaper ships can take care of that. Of course, a scout can capture a site as well as anything else, so on the way to the next nearest sector border, it should run over any sites it can.

Some players use a scout to scan for terrain on one turn and for ships on the next. This is a good idea only if no other ship along that border can easily reach a site in that sector. You need to capture a site in each newly scanned sector as quickly as possible so that you can build a base there. Bases in non-scan-blocking terrain will make a ship scan every turn, freeing up your scouts to move on to other sectors. Of course, if you have a heavy scout, this whole issue is moot, since these powerful units get a free ship scan when they make a terrain scan. If only they weren't so expensive! ★★★

## KLINGON MAXIMUM DEFENSE

by Chris Swearingen

Klingons are widely recognized as possessing superior offensive capabilities, but many players overlook the defensive might of Klingon technology. The technological foundation of Klingon defensive doctrine, which more than makes up for most ships' somewhat weaker defensive statistics, is, of course, the Stasis Field Generator (SFG). Ships with this enhancement possess the "Q" variant letter in Star Fleet Warlord and include the K-D5A, K-C9A, and several other fine ships.

A Klingon ship equipped with the SFG will automatically, as stated in the rulebook, "cancel the attack tactics of the enemy fleet", a simple enough effect, until one examines the impact of this capability on fleet battles in SFW. First, only *one* ship in your fleet needs to be equipped with the SFG to provide this effect *for that entire fleet*. Second, this system can reduce your opponent's offensive power by up to 15%, or even more (30%) if defending against those annoying ISC! This can be especially nice when the ISC come charging down with their overpriced scows in a smug echelon formation fully expecting to roll over your poor defenseless Klingons, only to be splattered like over-ripe fruit against your defensive wall (OK, so I'm a little partial to the Klingons).

SFG-equipped ships are available from the start of the game and become economically feasible in Y172 with the introduction of the D5A for only 118 EPs. Most players won't buy an SFG ship early because they don't have a fleet yet that needs one, so the Y165 ships tend to be lower in price (although this article may drive their prices up a bit). This allows all of your combat detachments and fleets to include an SFG-equipped ship. An example may be in order here to illustrate the usefulness of the SFG. You have a 530-DF fleet, complete with D5A, casually inhabiting some area where your opponent desperately wishes to be, hopefully *his* Home Office. His 500-AF fleet is primarily composed of one race, and he naturally has his Corporation's combat tactics set to match that race's preferences. Without the effect of the SFG-equipped D5A, he will have a total attack factor of 575 (650 if ISC), assuming all ships are of the preferred race, and with that much AF, he might well rid the universe of your genius. With your SFG-armed D5A, though, you'll only be facing a 500-AF fleet and may yet retain what is rightfully yours. With that one ship, you've robbed your opponent of 75 AF (or 150 if he was using the ISC), the equivalent of a dreadnought or more! And that's when he's using a *small* fleet—they can get a *lot* larger!

So in summary, if you're using Klingons, be sure you have a stasis ship in every fleet. Truly, the Klingons are masters of both offense and defense! ★★★

## WARLORD WRITERS NEEDED!

Got an idea, strategy, or tactic which you could meld into an article for Captain's Log or the Warlord Newsletter? Or even a short bit of fiction? Send it to Agents of Gaming, P.O. Box 31571, Dayton OH 45437-0571 or to B.GRAW1 by Email on GENIE, or B.GRAW1@genie.geis.com by Internet. There might be a free turn or two in it for you if your article gets published!



ART GALLERY

When we designed the new 96-page format, the top question was "What do we put on the extra pages?" We wanted to add at least one entirely NEW feature, rather than just giving you more of the great stuff in the old 80-page layout.

The top idea that came up in surveys was an Art Gallery, a place where Star Fleet Universe art could be displayed even if it wasn't for a specific story or scenario or article. (The ADB editing style is so chaotic that they never know what "spaces" they will have for art until the last minute, when it's difficult to get specific art ordered and approved.) The Art Gallery will allow us to print the best of SFB art without having to worry about finding some text that "goes with" that picture.

We are interested in publishing a wide variety of art styles and techniques, as well as the broadest possible range of subject material. If you want to submit art for Captain's Log, send photocopies of your work to Tim Olsen at Task Force Games.

Unfortunately, the idea for an art gallery came too late for our artists to respond in time, so Steve Cole provided some never seen before computer art to establish the concept and whet your appetite for REAL art next issue!

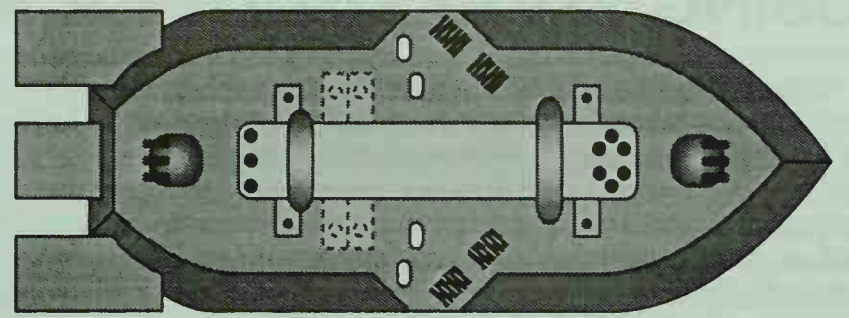
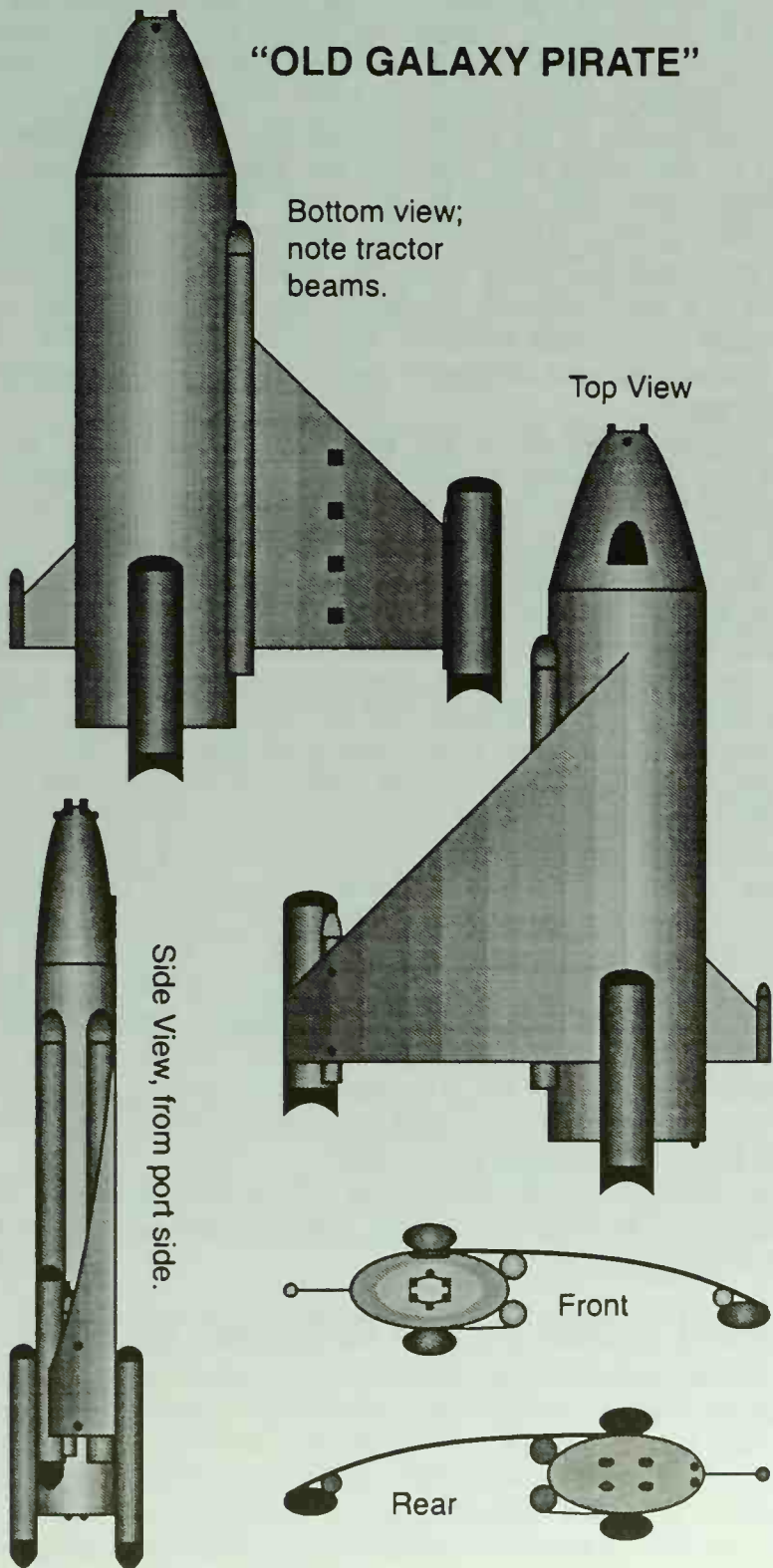

FRAX DREADNOUGHT

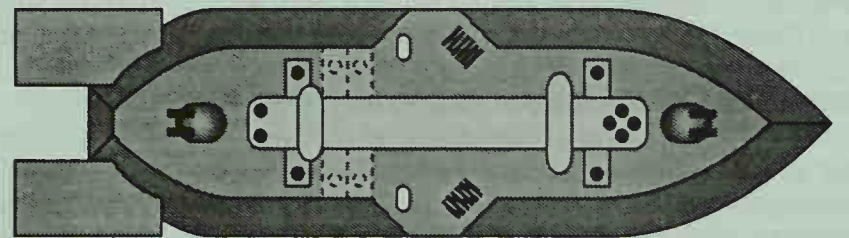

FRAX HEAVY CRUISER

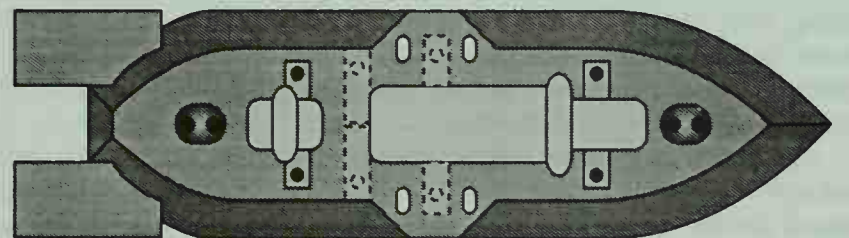

FRAX STRIKE CARRIER

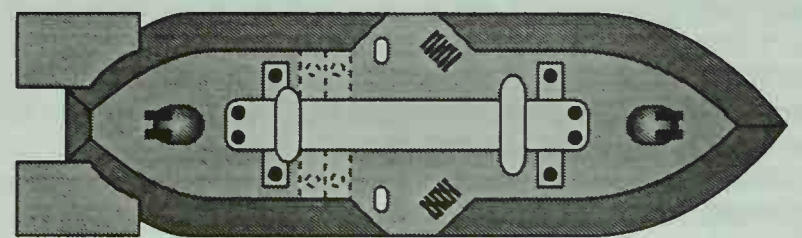

FRAX WAR CRUISER

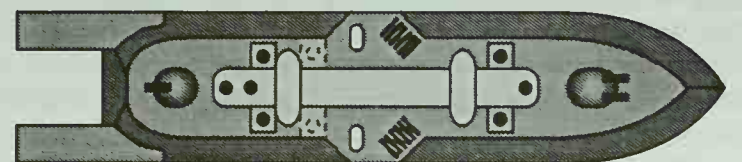

FRAX WAR DESTROYER

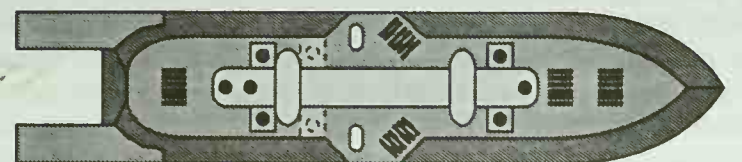

FRAX MISSILE DESTROYER

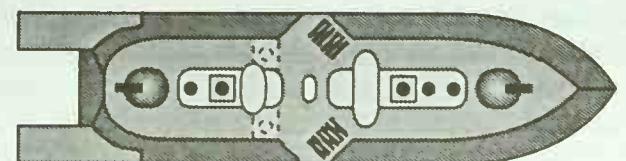

FRAX FRIGATE



(R91.0) THE FRAX



**(R91.1A) HISTORY:** The Frax do not exist, not even to the extent that the rest of the Star Fleet Universe exists. They are a pseudo-race (conjectural, as it were), with no area on the F&E map, no history, no culture, no religion, no production, and no home planet. We don't know what they look like, breathe, eat, or think. It does not matter, and it will not change.

The Frax are a creation of the Klingon Deep Space Fleet, intended to train captains in dealing with an unknown enemy.

**(R91.1B) GEOGRAPHY:** Given their armament (disruptors and drones), the Frax should be used against the "Western Powers" (Klingons, Kzintis, Lyrans), and possibly the Feds and Hydrans. If you really want to use them in your campaign, you could install them in the Kaltic Freestates (the four northernmost provinces of the Klingon Empire on the F&E map).

**(R91.1C) WEAPONS:** The Frax use disruptors, type-B drone racks, phaser-1s and phaser-3s. They use the same Y175 refit as everyone else (and in fact were the "first" units to receive it, as early as Y172!). The Frax also have an AFD refit (R91.1F). Drone speeds will be appropriate to the year.

Armament options could be considered. You could replace the disruptors with photons, but this is not recommended because the firing arcs will not work well with the slower rate of fire. You could also replace the disruptors with plasma torpedoes (S-torps with FP arcs replacing the FX disruptors, and F-torps with RP arcs replacing the RX disruptors), but this will dramatically change the operating characteristics.

The Frax use Klingon drone percentages.

**(R91.1D) FIGHTERS AND PFs:** Fighters and PFs are provided.

**(R91.1E) GENERIC UNITS:** The Frax use the Klingon version of the generic units (bases, armed freighters, monitors, Q-ships, FRD); delete the security stations.

**(R91.1F) ANTI-FIGHTER DEFENSE SYSTEM (AFD):** This system combines an ADD-12 (normal reloads and reload rules, cannot fire type-VI drones) with a phaser-G in a single mount. The mount can fire either gatling or ADD shots in a given impulse, but not both, and can switch between impulses without delay. Both the ADD and phaser-G can fire at their maximum rate, and both have the same firing arcs (noted on SSD). The AFD can only engage size-6 or size-7 targets. It is destroyed by drone OR phaser hits and has the place in the priority list of the component system (phaser-G or ADD-12). The phaser-G is affected by EW; the ADDs are not. Cost to repair is 12; can be hastily repaired as ph-3, ph-G, or ADD but not a combination. [Systems repaired in this manner are still under the AFD restrictions.] The AFD can only be used by the Frax, not other races. Availability is often stated by Class Year:

- 1st (Commander) Class: All Frax have AFDs.
- 2nd (Leader) Class: Carriers, escorts, and 1/3 of warships.
- 3rd (Warrior) Class: Carriers, carrier escorts, BB, CC.
- 4th (Trainee) Class: Carrier escorts only.

These levels can be used to balance player campaigns using the Frax. The SSDs are done for the Warrior Class.

**(R91.1G) FRAX MISSILE RACKS:** The larger Frax submarines and the Missile Destroyer used "missile racks" (hit on "best" drone rack) to increase their firepower. These operate like drone racks except: They only hold four type-IV drones (and cannot hold any other type of drone, except a type-V in the appropriate years); they cannot be reloaded; the ship can fire one "missile" (drone from a missile rack) every impulse (one total, not one per rack) even while cloaked.

FRAX WARSHIPS

**(R91.2) DREADNOUGHT (DN):** This ship is dangerous from any direction! The unified hull provides a significant "seventh shield" against penetrating damage. Unlike most Frax ships, which must divert phaser-1s to drone defense due to the lack of ADDs, the dreadnought has enough phaser-3s to take care of itself. Maneuverability is very good, which is a good thing because of the unusual weapons arcs.

**(R91.3) HEAVY CRUISER (CA):** The powerful forward phaser battery is a force to be reckoned with. Reserve power and unified hull make this one solid and dependable.

**(R91.4) WAR CRUISER (CW):** This was the original Frax ship and is still one of the best balanced. Very maneuverable. The small number of hull boxes is offset by unification. Note the large shuttle bay compared to other CWs. A tad short on power. Pentagonal shields (#2-#3-#4-#5-#6 are equal) are a requirement of the weapons arcs.

**(R91.5) WAR CARRIER (CWV):** Extremely fast, albeit this is due to a lack of heavy weapons. The ship can zip in, deposit the fighters, then get (and keep) out of the way. Without its fighter group, this ship is grossly undergunned. It has double seeking weapon control.

YEAR	ESCORTS	FIGHTERS
Y170-175	CWE, DWE	Demon 1 or 2
Y176-Y179	CWA, DWA	Demon 3
Y180+	CWA, DWA	Demon 4

**(R91.6) PF TENDER (PFT):** A variant of the CW and typical of the breed. Designed by Ken Burnside.

**(R91.7) WAR CRUISER ESCORT (CWE):** A fairly standard conversion based on the experience of the Klingons. Has limited aegis fire control. If not using the AFDs, replace them with phaser-3s and reduce the BPV by 8 points.

**(R91.7A) WAR CRUISER AEGIS ESCORT (CWA):** The same ship with full aegis.

**(R91.8) FRAX BATTLESHIP:** This ship was actually used in the simulators of the Klingon War College for the original combat tests of the B10! Has double seeking weapon control.

**(R91.9) FRAX COMMAND CRUISER:** One of the larger Frax ships, the Command Cruiser shows the traditional improvements over the Heavy Cruiser class and something extra: the AFD system!

**(R91.10) WAR DESTROYER (DW):** Adequate power and a fair turn mode make this a solid war destroyer, but not a brilliant one. The lack of redundant command facilities is a hidden Achilles' Heel. Within the Frax Fleet, it was war destroyers, rather than war cruisers, that provided most variants.

NOTE: A special SSD is provided for the five DW variants listed below. Simply use the relevant portion of that SSD.



**(R91.11) WAR DRONE DESTROYER (DWD):** An unexceptional drone bombardment platform, its best use is as a drone-defense unit for the entire fleet. Against an enemy without drones, it provides a useful offensive punch.

**(R91.12) WAR DESTROYER SCOUT (DWS):** Like most small scouts, the lack of adequate power prevented it from getting full use of its sensors. The number of sensors was, itself, inadequate, but there was not power for more.

**(R91.13) WAR DESTROYER MINEHUNTER (DWM):** Typical for the size class, but with fewer mine racks than most other races. Capable of defending itself in moderate actions, like most small hulls it is vulnerable in a fleet battle.

**(R91.14) WAR DESTROYER ESCORT (DWE):** Phasers and their firing arcs make this a superb drone defense unit, although the lack of ADDs and fast-firing racks able to use type-VI drones remained a problem. The AFDs used in advanced simulation levels made this ship devastatingly effective, although there was not room for them on the SSD in this product. The ship has limited aegis.

**(R9.15) WAR DESTROYER AEGIS ESCORT (DWA):** The same ship as the DWE, but with full aegis.

**(R91.15A) MISSILE DESTROYER (MDW):** This unit is the same as the DWD, except that the added drone racks are replaced by (R91.1G) Missile Racks. No SSD is provided, but it is very easy to adapt the SSD of the DWD variant to this need.

**(R91.16) WAR DESTROYER LEADER (DWL):** This ship was not available at press time. Add one Ph-1-FX, one APR, one LAB to the DW; the BPV is 100, crew 32, BPs 10.

**(R91.17) COMMANDO WAR DESTROYER (DWG):** Mounts X and Y are cargo; Z is a transporter. Replace the two APRs with one HTS shuttle; the other two shuttles are GAS. Change two Hull to barracks; add 20 boarding parties (including two HWS); has two ground combat vehicles. Has Other data same as DW.

**(R91.18) CARRIER (CV):** Built on the hull of a heavy cruiser, the CVS gave up all of its heavy weapons but retain the phasers. The huge hangar amidships has four hatches to allow quick launches and recoveries. The SSD shows the AFDs; if not using them, replace them with phaser-3s and reduce the BPV by 8 points.

YEAR	ESCORTS	FIGHTERS
Y170-175	CWE, DWE	Demon 1 or 2
Y176-Y179	CWA, DWA	Demon 3
Y180+	CWA, DWA	Demon 4

**((R91.19) TUG (TUG):** Built on a heavy cruiser hull (or rather, on a simulated version of one), the tug carried standard Klingon pods (actually, simulations thereof). [As it is a simulation, it could theoretically be configured to carry (a simulation of) ANY pod for purposes of training and testing, although the image of Gorn pods under such a ship is rather humorous. Such an "experiment" could only be done with the permission of the opponent.] Note that the shuttle bay includes one HTS.

**(R91.20) FRIGATE (FF):** Fast and maneuverable, the Frax Frigate can undertake independent patrols and give a good account of itself against even destroyers. In a fleet battle, the firing arcs make this unit superb at the job all size-4 units are supposed to be doing in fleet battles: killing things that dare to get close to the bigger and more important ships and taking care of small details to free larger ships for larger tasks.

**FRAX SUBMARINES**

The Frax submarine continued the testing process with something theoretically impossible: launch weapons while cloaked! The Frax submarines can launch drones (and no other weapons) while cloaked, using the passive fire control rules. All Frax submarine drones have ATG at no cost. Drones can be controlled normally if the ship is not cloaked. Scatter-packs cannot be launched while cloaked. Note that the drone racks have restricted firing arcs, something "real" ships do not have. Four of the submarine SSDs were printed elsewhere and are not reprinted here to avoid duplication. SubSpace News #2 and Starletter #89 are available from Task Force Games for \$2 each. They will only be available for a limited time!

**(R91.21) SUBMARINE FRIGATE (SFF):** The smallest of the subs, it was used to train small warships and police ships for convoy escort situations. The SSD is in SubSpace News #2.

**(R91.22) SUBMARINE DESTROYER (SDD):** This ship has a movement cost of 1/2. This was the primary Frax submarine used in "The Frax War" (a Klingon command training exercise). The SSD was in Starletter #89.

**(R91.23) SUBMARINE WAR CRUISER (SCW):** Large enough to give a good fight against a real warship, the SCW was the most common duel opponent. A tough opponent for a destroyer, and still a challenge for a war cruiser. The SSD is in SubSpace News #2.

**(R91.24) SUBMARINE MISSILE CRUISER (SCG):** This large submarine was designed for a specific purpose: attacking bases! The huge (albeit one shot) missile wave was enough to overwhelm the defenses of a fully armed battle station. The SSD is in SubSpace News #2.

**(R1.25) SUBMARINE LIGHT CRUISER (SCL):** This sub was designed to provide a true "dueling opponent" able to fight a standard warship on even terms. It must, of course, surface to fire the disruptors, but when it comes up to fight, be ready for it!

**FRAX ATTRITION UNITS**

**(R91.F1) DEMON-1 FIGHTER:** The Demon-1 has 8 damage points, 1xPh-3, and 2 type-I drones. BPV = 6, DFR = 2, Y168.

**(R91.F2) DEMON-2:** The Demon-2 has 10 damage points and two type-I drones. BPV = 8, DFR = 3, Y172.

**(R91.F3) DEMON-3 FIGHTER:** The SSDs show this fighter, which is, obviously, the same fighter as the Kzinti TAAS and the Klingon Z-Y. BPV = 9, DFR = 4 (two chaff), Y175.

**(R91.F) DEMON-4:** The Demon-4 has two "special" rails for type-III drones in addition to the Demon-3 rails. BPV = 11, DFR = 4 (two chaff), Y180.

**(R91.PF1) FAST PATROL SHIPS (PF):** The Frax PFs, like their warships, emphasize the FX/RX firing arcs and engage an enemy to one side, rather than head on. They are dangerous opponents in a PF duel due to their all-around weapons arcs. Designed by Ken Burnside.

**(R91.PF2) DRONE PF (PFD):** A drone-armed variant of the PF, it was integrated into Frax PF flotillas.



## VARIATIONS ON A MINI-THEME

In keeping with the Mini-themes, we have included scenarios with Maulers, X-ships, Jindarians, Frax, and of course the scenario for the story. Let's begin there . . .

## (SL148.0) A SENSE OF OBLIGATION

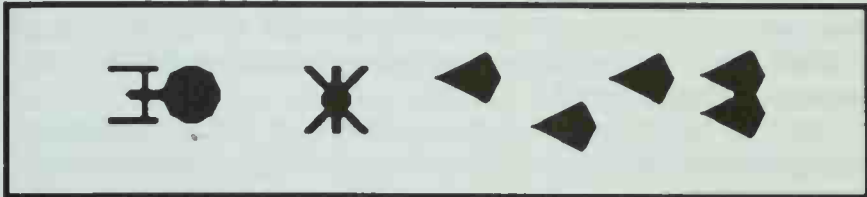

(Y166)

by Rob Milcik, Illinois

The rescue of the Scout *Bowie* by Captain Phil Kosnett in Y165 was heralded as a great accomplishment. Most Federation citizens were unaware that the *Bowie* had been on a clandestine penetration mission into the mysterious Tholian Holdfast. Even fewer were aware, or gave much thought to the concept, that other such operations were probably being conducted. In truth, in Y159 one such clandestine operation, disguised as a freighter, had penetrated into the Holdfast. The freighter had vanished utterly.

One of the senior officers on the freighter was Lt Commander Hans Fregessan. Hans Fregessan had been the oldest of four children when his parents had died in a shuttle crash. He had managed to keep the family together and, eventually, had joined Star Fleet. The youngest of his three siblings was Sven Fregessan, and he had followed his older brother into the fleet determined to repay the debt he felt he owed his elder brother.

Sven was convinced that his brother was alive and held by the Tholians. For political reasons, the Federation chose to ignore any chance that any members of the crew of the freighter *Ubichi Ranger* might be alive. It was the goal of the Federation to seal the Tholian-Federation neutral zone to communications between the Klingon and Romulan Star Empires. Inquiring into the fate of the *Ubichi Ranger* might endanger the negotiations, besides being an admission that the ship was indeed on an intelligence gathering mission. Sven Fregessan pulled every string he could find to keep himself assigned to, or as close as possible to, the Tholian-Federation neutral zone. He talked to any free trader or other merchant who had any dealings across the zone, and he volunteered to serve as an aide to any diplomatic embassies to the Holdfast. He carefully perused any intelligence that the Federation might gather on the Holdfast that he could gain access to.

Strangely, this obsession of his passed unnoticed by his superiors, and Sven's otherwise exemplary service eventually garnered him command of a cruiser in Y164, albeit an old "R" class, the *Ramilles*.

Going over the findings of the *Bowie*, Sven finally found what he was looking for when he compared the notes from his own studies. The Tholians seemed to employ some humanoids in the construction of their bases. Since pressure suits for humanoids were not as dense as those for Tholians due to the lesser need to retain heat, and since there was no place a person could escape to in space, it made perfect sense.

In Y166, the final pieces fell into place. Captain Fregessan received an "eyes only" message from Star Fleet, and he already knew that the Tholians were establishing a new base. He had already prepared a falsified message he would present to his own senior officers, and after briefing them, the rescue attempt was on.

(SL148.1) NUMBER OF PLAYERS: 2; the Federation player and the Tholian player.

## (SL148.2) INITIAL SET UP

FEDERATION: CA+ *Ramilles* enters from anywhere along the xx01 map edge on Turn #1; heading C, D, or E; speed max; WS-III.

THOLIAN: Mobile Logistics Base (phaser-1) *Akk-10* in 2215, with four cargo pods and two cargo modules attached, initial facing and rotation rate at the Tholian player's option, WS-I.

DD *Quartex* enters on Turn #4 from anywhere along the xx30 map edge; heading A, B, or F; speed max; WS-III.

PC+ *Obstinate* enters on Turn #6 from anywhere along the 01xx map edge, heading B or C, speed max, WS-III.

DPC+ *Trusty* enters on Turn #8 from anywhere along the 42xx map edge, heading E or F, speed max, WS-III.

CC *Protector* enters on Turn #10 from anywhere along the xx30 map edge; facing A, B, or F; speed max; WS-III.

(SL148.3) LENGTH OF SCENARIO: The scenario continues until all forces belonging to one side have been destroyed, captured, or have disengaged.

## (SL148.4) SPECIAL RULES

(SL148.41) MAP: The map is fixed; it does not float. Any unit leaving the map has disengaged and cannot return. The Federation units can only disengage in direction A. The Tholian units can only disengage in directions C, D, or E. Units which disengage in unauthorized directions are considered destroyed.

(SL148.42) SHUTTLES AND PFs: No shuttles or PFs have warp booster packs.

(SL148.421) If using the optional MRS shuttles, the Tholian CC may have an MRS. No other ship carried an MRS in this incident.

(SL148.422) There are no fighters in this scenario. In a variant in which fighters are present, use the standard deployment patterns (one EWF for each squadron of eight or more fighters) for EW fighters.

(SL148.423) There are no PFs in this scenario.

## (SL148.43) COMMANDER'S OPTION ITEMS

(SL148.431) Each ship can select additional or special equipment as Commander's Option Items (e.g., T-bombs, extra Marines, etc.) up to 20% of its combat BPV. See (S3.2) for details and exceptions.

(SL148.432) None of the ships involved in this action used drones [see (SL148.47)]. In a variant where drones are used, all drones are "slow," i.e., speed-8. Type-II and type-V drones (speed-12) and "medium" speed-20 drones are available for purchase as special drones.

Each drone-armed ship can purchase special drones up to the historical racial percentages as part of the Commander's Option Items. Note that (S3.2) allows drone ships extra points for this purpose.

(SL148.433) One of Sven Fregessan's assets for his raid was a Prime Team, *Ramilles' Redoubtables*, which was assigned to his ship. This team is represented by an additional boarding party over and above the normally assigned boarding parties and any extras purchased under (SL148.431). See (G32.0) for the rules on Prime Teams. There are no Tholian Prime Teams in this scenario.

(SL148.44) REFITS: At the time of this incident, all refits are as noted in (SL148.2).

(SL148.45) BASE: The BLM is a battle station under construction and has only been recently established, but its positional stabilizers are operating. In addition to its own normal (i.e.,



BLM) crew, there are 10 crew units of "humanoids". These are prisoners that the Tholians have taken in various incidents on all three of their borders and include: one Romulan crew unit, three Klingon crew units, two Orion crew units, and four Federation crew units. (Note that the Romulans are specific as there are no non-Romulans in the Romulan Empire, whereas the prisoners from the other three groups include mixtures of races.)

**(SL148.46) RESCUE:** The point of the scenario is for the *Ramilles* to rescue at least the Federation prisoners.

**(SL148.461)** To determine the location of a non-Tholian crew unit, the *Ramilles* must first attain level M intelligence (D17.0) on the station. Once this is attained, the Federation player knows the location of all prisoners on the station. Take a cup and place 10 counters in it: four Federation counters, three Klingon counters, two Orion counters, and one Romulan counter.

**(SL148.462)** To determine the specific race of the prisoners, the Federation player must gain 10 points of information under (G5.2) on the specific crew unit. The Federation player could gather information on up to nine crew units at one time (using a probe and his eight labs) or concentrate on a few by at time (using two or more labs on a single crew unit, for example). Use a scrap of paper to record how much information is collected on each individual crew unit. Once a crew unit is identified, the Federation player draws one counter from the cup to discover which prisoner unit he has found.

**(SL148.463)** Whether the nationality of a given crew unit is determined or not, the Federation player can attempt a hit-and-run raid to rescue a crew unit. If the crew unit was identified, he can roll for that specific unit. If he rolls for a crew unit that is not identified, he rolls the hit-and-run; if he succeeds, he randomly draws a crew unit from the cup to see who he rescued. The die rolls are resolved as follows:

- 1 BP returns with rescued crew unit.
- 2 BP killed, but crew unit rescued.
- 3 BP killed, crew unit unharmed, but unrescued.
- 4 BP killed, crew unit unharmed, but unrescued.
- 5 BP killed, crew unit unharmed, but unrescued.
- 6 BP returns, no crew unit rescued or harmed.

If an outstanding crew boarding party, commando boarding party, or Prime Team [see (SL148.433) above] makes the attempt, use the following table:

- 1 BP returns with rescued crew unit.
- 2 BP returns with rescued crew unit.
- 3 BP killed, but crew unit is rescued.
- 4 BP killed, crew unit unharmed, but unrescued.
- 5 BP returns, crew unit unharmed, but unrescued.
- 6 BP returns, crew unit unharmed, but unrescued.

Poor crews attempt rescues on the following table:

- 1 BP killed, but crew unit rescued.
- 2 BP killed, crew unit unharmed, but unrescued.
- 3 BP killed, crew unit unharmed, but unrescued.
- 4 BP killed, crew unit is killed.
- 5 BP returns, crew unit is killed.
- 6 BP returns, crew unit unharmed, but unrescued.

**(SL148.47) NON-VIOLENT COMBAT:** The Federation player must use Non-Violent Combat, as he must attempt to keep the incident as low key as possible, and slaughtering Tholians is not going to accomplish this. Because NVC is in use, the Federation drone rack is off-line and cannot be used.

**(SL148.48) THOLIAN REACTION:** The Tholians really are not sure just what is going on, but they will not attempt to guard the prisoners, transfer them to other units, or execute them. Their primary interest is in saving the station and making the Federation ship go away (or destroying it, of course). The Tholians will not perform hit-and-run raids in an effort to recapture the prisoners.

**(SL148.5) VICTORY CONDITIONS:** If all four of the Federation crew units are rescued and no more than 10 crew units of Tholians become casualties, including wounded (G9.23), the Federation player "wins".

**NOTE:** No matter what the outcome of this engagement, Captain Sven Fregessan will be relieved of command and court-martialed, but he considered it worth the price if he could save his brother. Players who doubt this should consider the ramifications of sanctioning commanders of warships using their vessels to settle personal scores.

**(SL148.6) VARIATIONS:** The scenario can be played again under different conditions by making one or more of the following changes:

**(SL148.61)** Substitute a Romulan KR (no B-refit) for the *Ramilles*. The Romulan will not worry about "political" considerations and is not required to use Non-Violent Combat. However, one of the prisoner crew units will die for every 10 internals scored on the station in addition to any Tholian casualties. The Tholian player will draw a random counter and keep this concealed from the Romulan player until the scenario is over. Since there is only one Romulan prisoner crew unit, it is possible that the Romulan may kill it first and render the whole point of the scenario moot without knowing it until the end.

**(SL148.62)** Change the cargo modules on the BLM to power modules, and add a web surrounding the station, strength 10 at start. Assume another Fregessan sibling was involved in the plot and brought in a frigate to assist Sven in the attempt (or that Sven found a frigate captain with a similar sense of obligation who was also missing a sibling from the *Ubichi Ranger* or some other failed intelligence mission).

**(SL148.63)** For a smaller and faster battle, use a frigate in place of the CA and delete the DD and CC from the Tholian reinforcements.

**(SL148.64)** Fregessan's XO was suspicious of the mission orders and might have been trying to determine if they were real by various checks and inquiries. To simulate this, roll one die at the start of each turn and record the result. When the total reaches 30, the XO has determined that his captain is not operating on legal orders and relieves him on the spot. At this point, the Federation cannot win the scenario and further rescue attempts cannot be made. The Federation ship can, if it successfully disengages, at best claim a draw.

**(SL148.7) BALANCE:** The scenario can be balanced between players of different skill levels by one or more of the following:

**(SL148.71)** Change the CA+ to a CC, or delete the plus refit.

**(SL148.72)** Replace the PC+ with another DD.

**(SL148.73)** Reduce or increase the number of Federation prisoner crew units.

#### **(SL148.8) TACTICS**

**FEDERATION:** Get within 4 hexes as quickly as possible so that you can start your 96-impulse clock for level M information. Smash a shield and stay on it. Use probes and labs as soon as you can, but do not wait to identify exact teams to send the first regular boarding parties over. Do not shoot at the base except to smash a shield; save your energy for the Tholian ships. Stay between the Tholian ships and the BLM.



**THOLIAN:** Use OEW and shuttles to best effect. Set the base to rotate two or more times a turn. Get your ships between the Federation ship and the BLM.

**(SL148.9) PLAYTESTER COMMENTS:** An exciting scenario requiring different tactics, fun, a challenging puzzle.

**(SL148.X) DESIGNER'S NOTES:** When we received this scenario, we all said, "This would make a great story!" And so it came to be, as we commissioned Bruce Graw to create the story in this issue based on the scenario. This is, so far as we know, the first time that the scenario was done first.

**HISTORICAL OUTCOME:** See the fiction story "A Sense of Obligation" in this issue of Captain's Log for the outcome.

**(SL149.0) STOP THE JINDARIANS!**

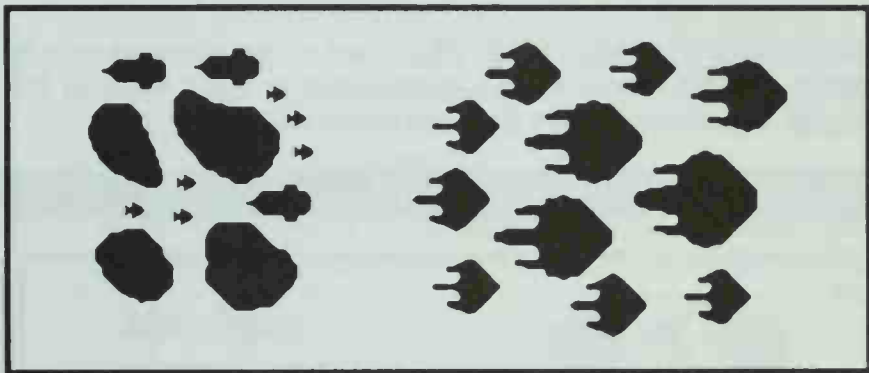

(Y175) *by Steven Paul Petrick, Texas*

The Jindarians ignore galactic conditions, including borders and current political situations. Their movements appear random; at least no one has ever managed to find a discernible pattern to the movements of any Caravan. This lack of a pattern makes it difficult to predict when a Caravan might suddenly cross a border into space occupied by another power. Usually, there is little or nothing that can be done to block such a movement given their brief nature. During times of war between empires, however, the Jindarians sometimes find themselves moving close to, or directly into, a fleet assembly area. In these circumstances, they find themselves opposed by a force intent on turning them back into the region they were departing.

**(SL149.1) NUMBER OF PLAYERS:** 2; the Jindarian player and the Non-Jindarian player.

**(SL149.2) INITIAL SET UP**

**JINDARIAN:** DN, BCH, CA, CVL (8x Meteor-2), DDA, FFA, DD, set up anywhere within 5 hexes of 2206, heading D, speed max, WS-III.

**NON-JINDARIAN:** Ships totaling no more than 1400 BPV including drone speeds and Commander's options, no survey ships or more than one scout, set up anywhere within 5 hexes of 2225, heading A, speed max, WS-III. This force must be consistent with the rules for Patrol Scenarios (S8.0). See also (SL149.48).

**(SL149.3) LENGTH OF SCENARIO:** The scenario continues until all forces belonging to one side have been destroyed, captured, or have disengaged. See (SL149.45) and (SL149.46).

**(SL149.4) SPECIAL RULES**

**(SL149.41) MAP:** Use a floating map. The Jindarian units can only disengage in directions A or D. The Non-Jindarian units can only disengage in directions C, D, or E. Units which disengage in unauthorized directions are considered destroyed.

**(SL149.42) SHUTTLES AND PFs:** No shuttles or PFs have warp booster packs.

**(SL149.421) MRS shuttles** may be purchased [up to the limits in (J8.5)] under (SL149.431).

**(SL149.422)** If using EW fighters, one of the Meteor-2 fighters on the Jindarian CVL is a Meteor-2E. If fighters are used by the Non-Jindarian player, he uses the standard deployment patterns (one EWF for each squadron of eight or more fighters) for EW fighters. If not using EW fighters, the Meteor-2E is a standard Meteor-2.

**(SL149.423)** There are no PFs in the basic version of this scenario.

**(SL149.43) COMMANDER'S OPTION ITEMS**

**(SL149.431)** Each ship can purchase additional or special equipment as Commander's Option Items (e.g., T-bombs, extra Marines, etc.) up to 20% of its Combat BPV. See (S3.2) for details and exceptions.

**(SL149.432)** All drones are "medium," i.e., speed-20.

Each drone-armed ship can purchase special drones up to the historical racial percentages as part of the Commander's Option Items. Note that (S3.2) allows drone ships extra points for this purpose.

**(SL149.433)** If players wish to use the optional rules for Prime Teams (Jindarian Salvager Teams) (G32.0), they can purchase such teams (25 points each) as part of their starting forces (not part of Commander's Options).

**(SL149.44) REFITS:** The Jindarian player may install special sensors in the option mounts of two of his ships (R16.R1). The CVL is a true carrier (R16.R3). No other refits are available to the Jindarians in this scenario. The Non-Jindarian player may have any refits available to him in Y175, but these count against the total BPV of his force. Note that all Non-Jindarian ships must include the "Y175 refit" if it is applicable to them.

**(SL149.45) JINDARIAN RESOLVE:** The Jindarians are attempting to reach a new mining area selected after several years of scouting. They must continue to try to reach this site by disengaging by separation (C7.2) in direction D unless:

- any three asteroid ships are crippled, or
- the dreadnought is destroyed, or
- any two non-dreadnought asteroid ships are destroyed.

If any of the above conditions apply, the Jindarians must attempt to disengage by separation (C7.2) or acceleration (C7.1) in direction A. The Jindarians determine if they must disengage in direction A as the final step at the end of each turn (after applying any repairs). Note that if an asteroid ship is crippled at the end of a given turn, it is crippled for that turn's analysis even if it could be repaired to non-crippled status on subsequent turns. If a ship that was crippled at the end of one turn is not crippled at the end of a subsequent turn, it does not count as a crippled ship at that time. The Jindarians cannot disengage by acceleration in direction D because they are too close to their final destination (although they will not reach it during this scenario).

**(SL149.46) NON-JINDARIAN RESOLVE:** The Jindarians are heading toward an area of rich asteroid mining. The disruption that their operations will cause will have an effect on the production of the site, and in turn an effect on the war effort of the race. This must be prevented, but losses of ships must be kept to a minimum. The Non-Jindarian force must disengage if one-third of the involved ships (not fighters or PFs) are destroyed or if two-thirds of the involved ships are crippled. This determination is based on the BPV of the ships at the start of the scenario, including Commander's Options, fighters, and drone speeds. The Non-Jindarians determine if they must disengage as the final step at the end of each turn (after applying any repairs). Note that if a ship is crippled at the end of a given turn, it is crippled for that turn's analysis even if it could be repaired to non-crippled status on subsequent turns. If a ship that was



crippled at the end of one turn is not crippled at the end of a subsequent turn, it does not count as a crippled ship at that time and is deducted from the crippled total. Destroyed and crippled ship totals are combined by adding the two totals. Thus, if one-sixth of the force were destroyed, and three-sixths of the force were crippled, it would have to disengage.

**(SL149.47) DESTRUCTION:** Neither side wants to start what would amount to a blood-feud as a result of this encounter. Once one side has been defeated, i.e., forced to disengage, the scenario is ended. Non-Jindarian forces are never certain how much cooperation there is between Jindarian elements and, in the middle of a major war, cannot afford to encourage additional Jindarian forces to be deployed against them. For the Jindarians, massacring a fleet could result in a vendetta against them or tip the scales so as to allow one side to win the war with possible consequences for the Jindarian's operations.

**(SL149.48) NON-JINDARIAN FORCES:** The Non-Jindarian force must include at least four ships of size class 4 and one ship of size class 3.

**(SL149.5) VICTORY CONDITIONS:** The Jindarians win if they successfully disengage in direction D. If any asteroid ship is captured, the Jindarian player has lost the scenario and will disengage after negotiating the release of the captured asteroid ship.

The Non-Jindarians win if they successfully force the Jindarians to disengage in direction A. If both sides are forced to disengage at the end of the same turn, the scenario is a draw.

Because they are involved in a war and trying to minimize their losses in what amounts to a sideshow, the Non-Jindarian forces can achieve higher levels of victory depending on how badly their forces are damaged in the battle. If the Jindarians are turned back and:

None of the Non-Jindarian ships were destroyed and less than 3/6ths were crippled, the Non-Jindarians win a decisive victory.

Less than 1/6th of the Non-Jindarian ships were destroyed and less than 3/6ths were crippled, the Non-Jindarians win a substantive victory.

Less than 1/3rd of the Non-Jindarian ships were destroyed and less than 1/3rd were crippled, the Non-Jindarians win a tactical victory.

Less than 1/3rd of the Non-Jindarian ships were destroyed but 1/3rd were crippled, the Non-Jindarians win a marginal victory.

**(SL149.6) VARIATIONS:** The scenario can be played again under different conditions by making one or more of the following changes:

**(SL149.61)** Change the year to Y183, and add a flotilla of casual PFs to the Jindarian force. Allow the Non-Jindarian player 210 additional BPV to purchase his force, but note that all drones will be "fast," i.e., speed-32, and must be purchased as such.

**(SL149.62)** Allow the Non-Jindarian player to form a combined fleet by purchasing ships from two or more allied races.

**(SL149.63)** For a smaller and more intense battle, delete the DN and CA from the Jindarian force and reduce the BPV to purchase the Non-Jindarian force by 534 BPV to 866 BPV (this includes points for Commander's Options).

**(SL149.64)** An obvious variation is to fight the battle to a conclusion, allowing both sides to "fight to the last ship" rather than disengage.

**(SL149.7) BALANCE:** The scenario can be balanced between players of different skill levels by one or more of the following:

**(SL149.71)** Change the Jindarian DD to a DW.

**(SL149.72)** Replace the Jindarian BCH with a DN or a CA.

**(SL149.73)** Increase or decrease the BPV available to the Non-Jindarian player to purchase his forces.

**(SL149.74)** Add or delete a Jindarian DD, or add a Jindarian FF.

#### **(SL149.8) TACTICS**

**JINDARIAN:** Cover the asteroid ships from direct assault as best you can. Your fighters and non-asteroid ships are expendable. Remember that without disengagement by acceleration you will have to virtually cripple every enemy ship.

**NON-JINDARIAN:** Your basic tactics will be determined by the race and force mix you choose. You will need to get past the Jindarian attrition units and small ships to strike their asteroid ships. While it is probably suicidal, going for a boarding capture could win the game. Remember, however, that your own ships are not really expendable, so watch your own losses carefully. Remember, there is a war on and you need every ship to fight the real enemy.

**(SL149.X) DESIGNER'S NOTES:** Part of the intent here is to create a battle in which both sides need to inflict loss on the enemy, but must preserve their own forces while doing so.

### **(SL150.0) INTERCEPTORS**

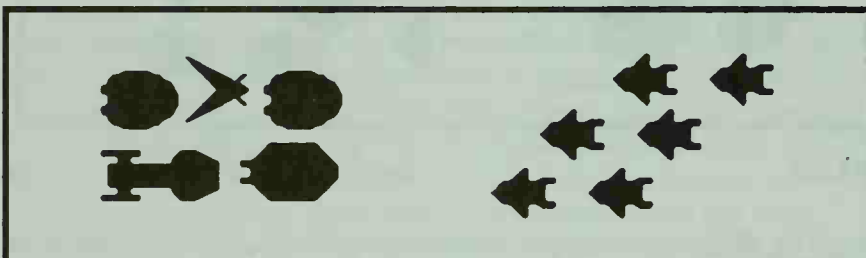

*by Michael Lay, England*

Supplies. Always the central issue in operations. If you can deny your enemy supplies, he will not be able to conduct operations or interfere with your operations. Truly vital supplies would be moved by so called "fast convoys" which had the speed to outrun a marauding cruiser or frigate. The advent of booster packs for interceptors would change that since they were now fast enough while arming weapons to pursue the convoys. Yet they were only harbingers of things to come.

**(SL150.1) NUMBER OF PLAYERS:** 2; the Interceptor player and the Convoy player.

#### **(SL150.2) INITIAL SET UP**

**INTERCEPTORS:** Six Interceptors within 3 hexes of 0228, heading B, speed max, WS-III.

**CONVOY:** Frigate ship in 2317, heading B, speed 6, WS-I. See (SL150.45).

LTT with cargo pod/pallet in 2116, heading B, speed 6, WS-I. See (SL150.45).

Free Trader in 2316, heading B, speed 6, WS-I.

Free Trader in 2117, heading B, speed 6, WS-I.

Armed Priority Transport in 2216, heading B, speed 6, WS-I.

**YEAR:** Players must select a year for the scenario as this will define available ships, refits, fighters, weapons, etc. The year selected should be the first year that interceptors are employed by the interceptor player.

**(SL150.3) LENGTH OF SCENARIO:** The scenario continues until all forces belonging to one side have been destroyed, captured, or have disengaged.



**(SL150.4) SPECIAL RULES**

**(SL150.41) MAP:** Use a floating map. The Interceptor units can only disengage in directions E or F. The Convoy units can only disengage in directions B or C. Units which disengage in unauthorized directions are considered destroyed.

**(SL150.42) SHUTTLES AND PFs:** No shuttles have packs. The Interceptors do have warp booster packs.

**(SL150.421)** No ship in this scenario is qualified to carry an MRS shuttle, but in a variant of the scenario where that is possible, they may be purchased [up to the limits in (J8.5)] under (SL150.431).

**(SL150.422)** If using EW fighters, one of the fighters in any squadron of eight or more fighters can be an EW fighters. If not using EW fighters, it is a standard fighter.

**(SL150.423)** The six Interceptors are a standard flotilla including one EW Interceptor.

**(SL150.43) COMMANDER'S OPTION ITEMS**

**(SL150.431)** The frigate and LTT can purchase additional or special equipment as Commander's Option Items (e.g., T-bombs, extra Marines, etc.) up to 20% of its combat BPV. See (S3.2) for details and exceptions. Note that whatever is spent here counts in the Modified Victory Conditions (S2.2) as victory points for the enemy.

**(SL150.432)** The speed of drones will depend on the year in which the scenario is set. See (FD2.223), (FD10.6), and (FD2.224). Each drone-armed ship can purchase special drones up to the historical racial percentages as part of the Commander's Option Items. Note that (S3.2) allows drone ships extra points for this purpose.

**(SL150.433)** Prime Teams (G32.0) are not available in this scenario.

**(SL150.44) REFITS:** The frigate and LTT can have any available refits.

**(SL150.45) SHIPS:** The Romulans should use an SPH as their LTT. The Gorns should use a DDF as their frigate.

**(SL150.5) VICTORY CONDITIONS:** Use the Modified Victory Conditions (S2.2).

**(SL150.6) VARIATIONS:** The scenario can be played again under different conditions by making one or more of the following changes:

**(SL150.61)** Replace the Interceptors with a flotilla of PFs. Add two police ships to the convoy escort.

**(SL150.62)** Replace the Interceptors with a squadron of class-III fighters with warp packs and (if the fighters are armed with drones) fast drones.

**(SL150.63)** For a smaller and faster battle, use only the LTT and frigate in the convoy. Use only three of the Interceptors (or two PFs).

**(SL150.7) BALANCE:** The scenario can be balanced between players of different skill levels by one or more of the following:

**(SL150.71)** Change the frigate ship to a destroyer.

**(SL150.72)** Replace the LTT's cargo pod with a self-defense pod.

**(SL150.73)** Delete or add an Interceptor, or add a police ship to the convoy.

**(SL150.74)** Some LTTs are better armed than others. If the LTT is not armed with heavy weapons (plasma torpedoes, disruptors, etc.) or drones, add a second FF to the convoy.

**(SL150.8) TACTICS**

**INTERCEPTORS:** Target the frigate and the APT with your initial fire as they are the only ships able to match your speed. Watch out for hidden mines as you need to keep a tight formation to use the EW interceptor to your advantage.

**CONVOY:** Those ships with slight or no engine damage could disengage by acceleration at the end of Turn #1, but then you hand the other side victory on a silver platter. You need to score some damage first. Take type-B drone racks on the free trader's option mount to divert some of the phaser fire and possibly arm a scatter-pack. Let the Interceptors close the range on Turn #1 (actually, you have not got much choice) while you fill up the phaser capacitors. Then on turn #2 pump up the EW and engage them with your heavy weapons.

**(SL150.9) PLAYTESTER COMMENTS:** A fun scenario illustrating why PFs needed bigger engines!

**(SL151.0) Q-INCIDENCE**

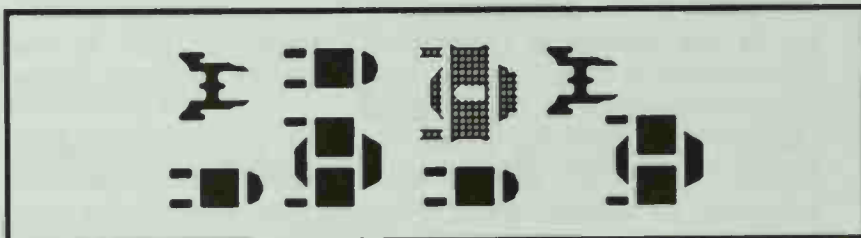

*by Robert Hamilton IV, Ohio*

During wartime, most races adopt a convoy system to better protect their supply lines. This annoys most Orion commanders since it makes it harder for them to "earn a living".

Orion Q-ship and armed freighter captains, on the other hand, find an advantage in that they can insert themselves into convoys and then pick their moment to strike, and their particular target.

Sometimes the convoy includes a friendly Q-ship, and when that happens, things can get interesting really fast.

**(SL151.1) NUMBER OF PLAYERS:** 2; the Convoy player and the Orion player.

**(SL151.2) INITIAL SET UP**

**CONVOY:** Three large freighters, three small freighters, two police ships, all within 3 hexes of 2215, heading B, speed 4, WS-0.

**ORION:** Q-Ship [see (SL151.45)], WS-III.

**YEAR:** Players must select a year for the scenario as this will define available ships, refits, fighters, weapons, etc. Y172 is assumed if no alternative selection is made.

**(SL151.3) LENGTH OF SCENARIO:** The scenario continues until all forces belonging to one side have been destroyed, captured, or have disengaged.

**(SL151.4) SPECIAL RULES**

**(SL151.41) MAP:** Use a floating map. All units can disengage in any direction.

**(SL151.42) SHUTTLES AND PFs:** The presence of warp booster packs (J5.0) on any fighters or PFs (to increase their speed) will depend on the year in which the scenario is set. They were introduced for fighters in Y180; PFs always have them, and Interceptors have them unless specified otherwise.

**(SL151.421)** No ship in this scenario is qualified to carry an MRS shuttle, but in a variant of the scenario where that is possible, they may be purchased [up to the limits in (J8.5)] under (SL151.431).

**(SL151.422)** If using EW fighters in a variation of this scenario where fighters in squadron strength are used, one fighter in any squadron or eight or more fighters can be an EW fighter. If not using EW fighters, it is a standard fighter.



(SL151.423) There are no PFs in the basic version of this scenario. If they are added as a balance factor or in a variation, they will be casual PFs carried on mech links and will be standard types, not variants.

**(SL151.43) COMMANDER'S OPTION ITEMS**

(SL151.431) Each ship can purchase additional or special equipment as Commander's Option Items (e.g., T-bombs, extra Marines, etc.) up to 20% of its Combat BPV. See (S3.2) for details and exceptions. Freighters not classified as "Armed" or "Auxiliaries" cannot have Commander's Options.

(SL151.432) The speed of drones will depend on the year in which the scenario is set. See (FD2.223), (FD10.6), and (FD2.224). The cost of drone speed upgrades is not included in the % limit in (SL151.431).

Each drone-armed ship can purchase special drones up to the historical racial percentages as part of the Commander's Option Items. Note that (S3.2) allows drone ships extra points for this purpose.

(SL151.433) No ship in this scenario normally carries a Prime Team (G32.0), but such Teams are sometimes assigned to various ships. Players may experiment with Prime Teams, perhaps as a balance factor.

**(SL151.44) REFITS:** Refits will be defined by the year selected for the scenario and may be omitted as a balance factor.

**(SL151.45) Q-SHIPS:** The following rules define the types of Q-ships and the procedures for determining which ship in the convoy is the Orion Q-ship and which might be the Convoy Q-ship.

(SL151.451) To determine the type of Q-ship the Orion player will use, the Convoy player indicates the race of the convoy and which border he is operating on for that race. Once this is done, the Orion player will note the types of Q-ships used by the Convoy race and what types are available to the neighboring race. (In some cases, the Convoy player might indicate to the Orion player that the convoy is in an area which borders two other races, although this will have little effect.) The Orion player will then select one large and one small Q-ship from one or the other race, or one from each, and write down this information.

(SL151.452) Once the type of Q-ship has been determined above, the Convoy player will set up the convoy and its escorts. The Orion player will number the freighters from one to six, while the Convoy player watches, and the Orion player rolls a die. The freighter corresponding to his die roll will be the Q-ship and might be either a large or small Q-ship, depending on the die roll.

(SL151.453) The Convoy player will now determine if one of the freighters is also a Q-ship. To do this, the players take 20 chits numbered from 1-20 and put them in a cup. The Convoy player then publicly numbers his five freighters from one to five. He then draws one chit, examines it and places it face down in plain view of the Orion player. The Orion player cannot examine this chit, or the chits in the cup after this one is drawn, until the scenario is ended or the Convoy player's Q-ship reveals itself. If the drawn chit was a number from one to five, the ship corresponding to that number is a friendly Q-ship. If any other number was drawn, there is no friendly Q-ship present in the convoy.

**(SL151.46) TURN ONE:** On the first turn, no ship in the convoy can plot any accelerations. No ship has reserve warp power available (reserve warp is only allocated when the ship is in battle or about to engage in battle). Excess power beyond life support, fire control, speed 4 movement, and shields (no non-battery shield reinforcement) is simply not generated. Battery power can be used for any function not requiring warp or impulse power on Turn #1. In addition, the convoy must con-

tinue to move in the current direction for four impulses after the Orion Q-ship reveals itself and cannot fire or launch any weapons, or launch any shuttles, until the start of the fifth impulse after the Orion Q-ship has revealed itself. None of these restrictions apply to the Orion Q-ship, but they do apply to any Convoy Q-ship.

**(SL151.47) REVELATION:** The Orion Q-ship has revealed itself on the impulse the Orion player actually takes charge of its counter, whether by announcing weapons fire or launch, by launching shuttles or fighters, or by moving the counter himself rather than allowing the Convoy player to move it, including mid-turn speed changes. In short, anything other than simply moving with the convoy will reveal the Q-ship.

**(SL151.5) VICTORY CONDITIONS:** If the Orion Q-ship can capture at least one freighter and disengage with it and his Q-ship, he wins a marginal victory. For every freighter more than one he captures and disengages with, his victory level is raised by one (e.g., disengaging with two freighters would be tactical victory, three freighters a substantive victory, four freighters a decisive victory, and five or more freighters an astounding victory). Large freighters count as two freighters for this purpose. If the Q-ship is destroyed, but the Orion player disengages at least one captured freighter, the scenario is a draw. If the Orion is forced to disengage without capturing any freighters, the convoy player wins a marginal victory. If the Orion is destroyed, and no freighters are captured and escape, the Convoy player wins a decisive victory. If the Orion is destroyed but one or more freighters were captured and disengaged, the scenario is a draw. If the Convoy player captures the Orion Q-ship, he becomes a Legendary Police Captain.

**(SL151.6) VARIATIONS:** The scenario can be played again under different conditions by making one or more of the following changes:

**(SL151.61)** Instead of a Q-ship, the Orion player uses an armed freighter. Prior to the scenario beginning, the Orion armed freighter had its additional weapons concealed behind panels (D17.74) and was operating its shields and engines at reduced levels [(D17.71) and (D17.72)]. Note that some weapons cannot be concealed by panels, and this will limit what armed freighters could be used for this. The scenario is deemed to have started just after the armed freighter has brought its shields and warp power fully on-line and blown the concealment panels. The weapons which were behind these panels will not be able to fire/launch until after Impulse #4 of Turn #1, but then all the convoy ships are at WS-0 for that turn and have little more than drones and some plasmas available to defend themselves.

**(SL151.62)** Add a cruiser controlled by a third player to the scenario. This cruiser should be from a hostile power crossing a common border into the Convoy player's space. This could be a non-historical enemy if the players agree. The cruiser's victory condition is to destroy the entire convoy, including the Orion Q-ship. The Orion's victory condition is still to capture a freighter and disengage with it and his Q-ship. The result is an uneasy alliance between the Convoy player and the Orion in order to defeat the cruiser; then they must fight between themselves. In this variation, the entire convoy, including the Orion Q-ships, starts at WS-I.

**(SL151.63)** Replace one of the escorts with a small Auxiliary Carrier. (Tactical hint: The Q-ship will have to hit this ship first and hard no matter what it is.) No fighters can launch on Turn #1.

**(SL151.64)** Add one or two PFs carried by the escorts on mech links if the scenario is set late enough to allow this.



(SL151.65) Require the Convoy player to select a chit from a cup of chits numbered from 3 to 9. The selected number is the number of impulses after the Orion Q-ship starts shooting that the Convoy player can react in any manner. The Convoy player must reveal the chit drawn when he first begins to fire or maneuver the convoy in reaction to the attack.

(SL151.7) **BALANCE:** The scenario can be balanced between players of different skill levels by one or more of the following:

(SL151.71) Change one of the police ships to an FF.

(SL151.72) Replace one freighter with an armed freighter.

(SL151.73) Increase the weapons status of the convoy to one.

#### (SL151.8) TACTICS

**CONVOY:** Once you know what the Q-ship is, keep the rest of your ships grouped for mutual defense. Be ready to send boarding parties over to assist in the defense of any freighter the Orion boards. Try to keep your Q-ship (if you have one) pretending it is another freighter until it can arm its weapons and hit the Orion for all it is worth. You may consider launching all of your shuttles as a "fighter squadron" to keep the Orion busy until you can cycle up your weapons. Note that as admin shuttles are not really fighters, you will not be able to lend them EW.

**ORION:** Like it or not, you have to take out the escorts first and fast. Try to hit one with everything and tractor the other until your weapons recycle and you can hit him. Once the escorts are out of the way, you will be damaged, so do not pussyfoot around. Grab a freighter and run. Only if you are minimally damaged should you consider grabbing more than one, but keep an eye out for the defending Q-ship.

(SL151.9) **PLAYTESTER COMMENTS:** This is an interesting scenario, not knowing which (if any) of the freighters are Q-ships adds a certain amount of tension to the game. Flying an underpowered, unmaneuverable bucket is not. Seriously, a good scenario in the tradition of "The Surprise Reversed". When it heats up, it heats up fast.

### (SL152.0) A NEST OF VIPERS

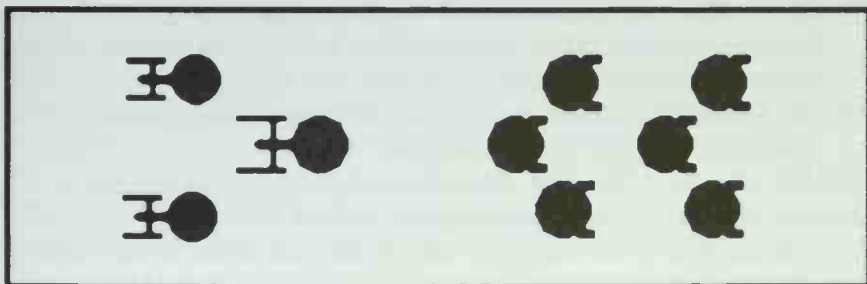

(Y205)

by Steven Paul Petrick, Texas

When the *Darwin* returned to Y195 (SH166.0), it brought with it all the available information that the future had on the Andromedans. Most of this information would prove useless due to an unforeseen corrupting of the files caused by the time transfer and the fact that the data had been transferred from the advanced computers of X-ships to a non-X ship. An example was a file listing the locations of all known Andromedan bases that had been found in that dark future in which all the critical location data was missing.

Analysis of the information did turn up a number of interesting items. One such item was that the Galactic Powers, in the desperation of the Andromedan War, had begun sharing technology to an unprecedented degree, resulting in the deployment of limited numbers of gatling-armed fighters by the Klingons (as well as other races), PFs by the Federation, and maulers by virtually every race.

One record was of an action of the Federation mauler *Velikovsky* during the retreat after the failure of Operation Unity in the alternate universe. Cut off from the main fleet, the *Velikovsky* was attempting to make its way back to a supply base when it apparently stumbled onto something (just what is unknown) that the Andromedans did not want found.

(SL152.1) **NUMBER OF PLAYERS:** 2; the Federation player and the Andromedan player.

#### (SL152.2) INITIAL SET UP

**FEDERATION:** Mauler *Velikovsky* in 2215 with two standard PFs on mech links, heading E, speed 10, WS-I. [As the *Velikovsky* is in Starletter #91, not CL#16, you can substitute the MCL or the Gorn or Kzinti mauler BC.]

**ANDROMEDAN:** Six Vipers arrive in accordance with (SL152.45), speed max, WS-III.

(SL152.3) **LENGTH OF SCENARIO:** The scenario continues until all forces belonging to one side have been destroyed, captured, have disengaged, or until the end of Turn #13.

#### (SL152.4) SPECIAL RULES

(SL152.41) **MAP:** Use a floating map. The Federation units can only disengage in direction E. The Andromedan units can only disengage in directions B, C, or D. Units which disengage in unauthorized directions are considered destroyed.

(SL152.42) **SHUTTLES AND PFs:** All shuttles and PFs have warp booster packs.

(SL152.421) No ship in this scenario is qualified to carry an MRS shuttle, but in a variant of the scenario where that is possible, they may be purchased [up to the limits in (J8.5)] under (SL152.431).

(SL152.422) There are no fighters in this scenario. In a variant in which fighters are present, use the standard deployment patterns (one EWF for each squadron of eight or more fighters) for EW fighters.

(SL152.423) The two PFs carried by the *Velikovsky* are standard Federation PFs.

#### (SL152.43) COMMANDER'S OPTION ITEMS

(SL152.431) Each ship can purchase additional or special equipment as Commander's Option Items (e.g., T-bombs, extra Marines, etc.) up to 20% of its Combat BPV. See (S3.2) for details and exceptions. Note that whatever is spent here counts in the Modified Victory Conditions (S2.2) as victory points for the enemy.

(SL152.432) All drones are "fast," i.e., speed-32.

Each drone-armed ship can purchase special drones up to the historical racial percentages as part of the Commander's Option Items. Note that (S3.2) allows drone ships extra points for this purpose.

(SL152.433) Prime Teams (G32.0) are not available.

(SL152.44) **REFITS:** The PFs have the shield refit.

(SL152.45) **ANDROMEDAN ARRIVAL:** At the start of each turn, before Energy Allocation, an Andromedan Viper will arrive. The arriving Viper must be set up 15 hexes from the *Velikovsky* or the PFs, whichever is closest, and must have the *Velikovsky* in its FA arc. The map locations may have to be adjusted to allow this by sliding the ships or by adding another map. The direction to the *Velikovsky* is determined by rolling a single die and comparing the result to the diagram around hex 0328.

(SL152.46) **ANDROMEDAN DISENGAGEMENT:** Each Viper must disengage by acceleration or distance by the end of its fifth turn on the board. Any undestroyed Andromedan unit that fails to disengage on its designated turn is destroyed.

(SL152.47) **VELIKOVSKY DISENGAGEMENT:** The *Velikovsky* is short on fuel and can only disengage by separation.



**(SL152.5) VICTORY CONDITIONS:** Use the Modified Victory Conditions (S2.201). The Federation player receives a bonus equal to double the BPV of any undestroyed Andromedan ship which fails to disengage by the end of its fifth turn in the scenario [such Andromedan ships are destroyed at that point per (SL152.46)]. The Federation player receives a bonus equal to the BPV of the *Velikovsky* itself if it survives.

**(SL152.6) VARIATIONS:** The scenario can be played again under different conditions by making one or more of the following changes:

**(SL152.61)** Replace the *Velikovsky* and its PFs with a cruiser mauler and two PFs of any race. Do not use Romulan SPF or FHF maulers in this substitution.

**(SL152.62)** Allow the Andromedan player to use a Courier Scout as one of his ships. He must tell the Federation player when this ship arrives.

**(SL152.63)** For a smaller and faster battle, use a war cruiser mauler with no PFs and only four Andromedan Vipers.

**(SL152.7) BALANCE:** The scenario can be balanced between players of different skill levels by one or more of the following:

**(SL152.71)** Change one of the Vipers to a Cobra.

**(SL152.72)** Use only five Vipers, or increase the number of Vipers to seven or eight.

**(SL152.73)** Delete one or both of the Federation PFs.

#### **(SL152.8) TACTICS**

**FEDERATION:** Launch the PFs, and try to keep the Vipers from linking up and attacking a single shield. Be careful how you use your power, as the batteries provide shield reinforcement and weapon power, but are also difficult to rearm while you are trying to maintain speed.

**ANDROMEDAN:** Take out the PFs; then mass for an all out attack on the ship. Watch the timing so that your Vipers disengage when called on to do so.

**HISTORICAL OUTCOME:** It is assumed that the *Velikovsky* escaped this battle, but the records are not clear. The report might have been sent by a doomed ship by subspace radio, or perhaps a log buoy was recovered. It is known that at least three Vipers were destroyed.

### **(SL153.0) STALKING SIEGEBREAKER**

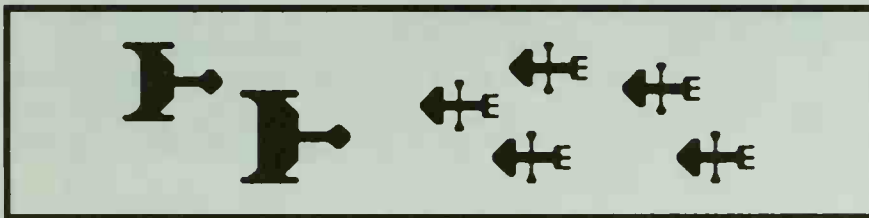

**(Y183)**

by Ken Burnside, Arizona

After a base assault collapsed, the remnants of a Klingon task force attempted to make their way home through hostile territory. Attempting to evade pursuit by moving through the Gitaarn Nebula, the D6MK *Siegebreaker* and D5K *Raven* were intercepted by the 171st Needle Flotilla at the extreme end of the PFs' life support range.

**(SL153.1) NUMBER OF PLAYERS:** 2; the Klingon player and the Kzinti player.

#### **(SL153.2) INITIAL SET UP**

**TERRAIN:** The entire map is a Quiet Nebula. See (P6.5) for more information.

**KLINGON:** D6MK *Siegebreaker* and D5K *Raven* in hex 2801 on the map edge, heading D, speed 15. WS-III.

**KZINTI:** The 171st Needle Flotilla in hex 4211, heading E, speed max, WS-III (4 standard PFs, 1 Leader).

**(SL153.3) LENGTH OF SCENARIO:** The Kzintis have until Turn #5 to destroy *Siegebreaker* and/or *Raven*. Any surviving Needles must disengage by the end of Turn #5, due to range limits. Any Needles that have not disengaged by the end of Turn #5 are deemed destroyed.

#### **(SL153.4) SPECIAL RULES**

**(SL153.41) MAP:** Use a floating map. See the terrain description above. The Klingon units can only disengage in direction D. The Kzinti units can only disengage in direction A.

**(SL153.42) SHUTTLES AND PFs:** Due to nebula rule (P6.41), no shuttles may be used in this scenario. In a variation where a nebula is not used, all shuttles would have warp booster packs. All PFs have warp booster packs.

**(SL153.421)** No MRS shuttles may be used due to (P6.41). Even in a variant without the nebula, none of the ships historically in this scenario carried an MRS. If using different ships, they may or may not be qualified to carry one, based on their class and description.

**(SL153.422)** No fighters, EW or otherwise, may be used in this scenario due to the Nebula (P6.41). In a variant without a nebula and with a carrier, standard EW fighter deployment (one per squadron of 8 or more fighters) would apply.

**(SL153.423)** The Kzinti PFs are a standard flotilla including 4 standard Needles and 1 Leader; the scout PF was previously destroyed.

#### **(SL153.43) COMMANDER'S OPTION ITEMS**

**(SL153.431)** Each ship can purchase additional or special equipment as Commanders Option Items. The Klingon ships are limited to 12% of their Combat BPV (rather than the customary 20%) to reflect ordnance expended in the base assault. Note that most of the normal purchases will not function in a nebula. See (P6.6) and (S3.2) for details.

**(SL153.432)** All drones are "fast," i.e., speed-32.

Each drone-armed ship can purchase special drones up to the historical racial percentages as part of the Commander's Option Items. Note that (S3.2) allows drone ships extra points for this purpose.

**(SL153.433)** Prime Teams (G32.0) are not available in this scenario.

**(SL153.44) REFITS:** The *Siegebreaker* and *Raven* have all applicable refits. The 171st Needle Flotilla has the shield refit, but due to (P6.3) this is irrelevant except in a variation where the nebula is not used.

**(SL153.45) SPEED RESTRICTION:** Due to fuel constraints, both Klingon vessels have a maximum speed of 20 using warp engines, plus 1 if impulse power is used (total 21). Erratic maneuvers count against the maximum allowed speed if warp power is used, but not if impulse power is used. HETs do not count against the maximum speed allowed, even on the impulse it is executed.

**(SL153.46) DISENGAGEMENT:** The Klingons, due to fuel constraints, can disengage only by separation. The *Raven* can sublight evade; the *Siegebreaker* cannot because this would mean dropping the mauler cannons, and the ship would effectively count as destroyed.

#### **(SL153.5) VICTORY CONDITIONS**

If both the *Siegebreaker* and *Raven* escape with no internal damage, this is an Astounding Klingon Victory.

If both the *Siegebreaker* and *Raven* escape uncrippled, this is a Decisive Klingon Victory.



If the *Siegebreaker* escapes uncrippled, and the *Raven* is crippled, this is a Substantive Klingon Victory.  
 If the *Siegebreaker* escapes uncrippled, and the *Raven* is destroyed, this is a Tactical Klingon Victory.  
 If the *Siegebreaker* is crippled, but both ships escape, this is a Marginal Klingon Victory.  
 If the *Siegebreaker* is crippled and the *Raven* is destroyed, this is a Draw.  
 If the *Siegebreaker* is destroyed, this is a Kzinti Victory.  
 If the Kzintis destroy both vessels, it's a Substantial Kzinti Victory.  
 If the Kzintis destroy both vessels with fewer than three destroyed PFs, it's an Amazing Kzinti Victory. If the Kzinti player manages to destroy both vessels without losing a PF, it's a Legendary Kzinti Victory.  
 If the *Siegebreaker* and *Raven* are undestroyed at the end of Turn #5, they are assumed to have escaped (resolve victory by above conditions); the Needles have reached the extreme end of their range and must disengage.

**(SL153.6) VARIATIONS:** The scenario can be played again under different conditions by making one or more of the following changes:

**(SL153.61)** Substitute another race's Mauler and War Cruiser for the *Siegebreaker* and *Raven*. For the Andromedans use a Terminator with a Python for support. Lyran units cannot use the ESG; Romulan units cannot cloak.

**(SL153.62)** Substitute another race's PF flotilla for the Kzinti Needles. Hydran Hellion PFs can be deadly. Remember to not use the scout.

**(SL153.63)** Substitute a Lyran CWp+ or Romulan SPA+ for the *Raven* to represent a coalition of forces. Lyran units cannot use the ESG; Romulan units cannot cloak.

**(SL153.64)** Use the standard Nebula rules, including the position shifts and random facing changes of (P6.5). This will make controlling large numbers of seeking weapons and a PF flotilla an onerous task.

**(SL153.65)** Play the scenario in open space, without the nebula. Alternatively, play it on a succession of special maps like those from Module B with various types of terrain. The Klingons should be given two standard PFs held on mech links on the D5 at the start of the scenario in either of these variations.

**(SL153.66)** Replace the D5K with any D5 variant, except that if an MD5 is used the D6M should be a standard D6K. A D5D might have advantages in that it need not turn to fire.

**(SL153.7) BALANCE:** The scenario can be balanced between players of different skill levels by one or more of the following:

**(SL153.71)** Reduce or increase the time limit on the scenario or the maximum speed of the Klingon ships.

**(SL153.72)** Allocate some internal damage to the *Siegebreaker*, the *Raven*, or the 171st Needle Flotilla.

**(SL153.73)** Reduce the D5K to a pair of E4Bs.

**(SL153.74)** Add an E4B or E4D to the Klingon side.

**(SL153.75)** Allow the *Siegebreaker* a Legendary Navigator.

**(SL153.8) TACTICS**

**KLINGON:** Run. With time on your side, you want to keep the distance as far open as possible. Try and force him into a stern chase, as this will make his drones easy to destroy with phasers when they get to you. This also has all your phasers in arc, if you're careful. When you have engaged, remember that you can stop an impressive number of drones with the D5's ADDs, drones, and phasers, as well as what's on the D6M. The best way to stop a drone wave is to blow up a PF with the drones in the same hex. This is tricky to arrange. If you can do it, there is no such thing as overkill in dealing with a PF. You

might consider separating your two ships so that their ADDs (at least the ones on the D5) can cover one another, but if the Kzinti PFs do not launch drones until they reach range 0, this will only give you two shots and will greatly dilute your defensive phaser fire in killing them. You will have to think long and hard about firing at the PFs as they come in, because killing one by emptying your weapons will not stop the other five from smothering you with their drones. It may be best to stay in the same hex so that you can at least mass your phasers to kill incoming drones. Use your own drones to keep the Kzinti busy, at least make them waste power shooting at them. If the Kzintis look like they will move slowly initially, you might gamble and try to set up a retrograde.

**KZINTI:** Move in fast. Hold your drones until at least range 6, due to (P6.73). As there are no T-bombs due to (P6.6), one of your best tactics is to group in one hex. Remember that *Siegebreaker* is the target, no matter how tempting a target the *Raven* is. Use EM and max ECM until the impulse before you will launch drones to minimize the Klingon's chances of damaging your PFs on the approach. Move at speed 31 on the first turn while doing so. This will give you (with the nebula) a total of 19 points of ECM, and force the Klingons to use at least 4 points of ECCM to avoid having a plus four shift on all direct-fire weapons, but there will still be a plus three shift. At range 0, the ADDs of the Klingon ships will be useless, and he will not be able to use labs to identify the drones before they hit and will have to assume all are type-IVs with perhaps some armor. Be wary that the Klingons MIGHT have HETs prepared to hit you as you come in.

**(SL153.9) PLAYTESTER COMMENTS:** This scenario will magnify any difference in skills between the two players, and it is balanced on a razor blade. This is the scenario that separates great Klingons from the merely competent. It's nearly that tough for the Kzintis. It requires careful planning by both sides.

**HISTORICAL OUTCOME:** *Siegebreaker* escaped with damage after the *Raven* was destroyed by the PFs. Several PFs were destroyed, but the records are unclear on this point since at least one badly crippled PF was seen leaving the area and may not have made it home.

**(SL154.0) THE MULAKEE**

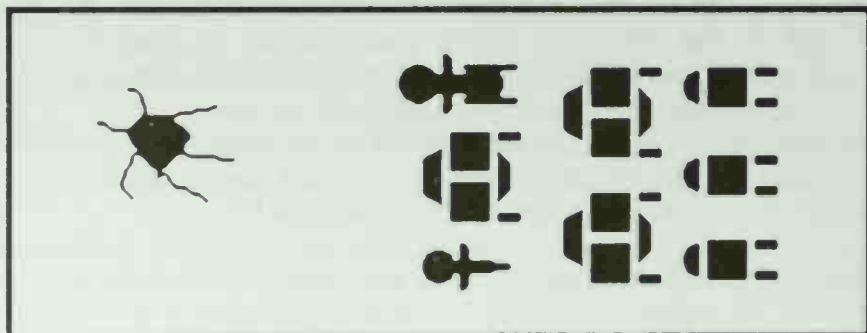

(Y163)

by Brett Gladman and Paul Dunn

In Y163, a Gorn convoy loaded with a munitions shipment (the Gorns were creating stockpiles near their Romulan border as part of their war preparations) discovered a new life-form. Unfortunately for the Gorns, they also discovered that the creature, which they named "Mulakee", was apparently attracted by the energy field of the munitions.

**(SL154.1) NUMBER OF PLAYERS:** 1; the monster(s) moves by automatic rules; see (SL154.45).



**(SL154.2) INITIAL SET UP**

**GORNS:** Tug *Thunderfoot* (1x cargo pod), 3x F-L, 3x F-S, all within 3 hexes of 1517, heading B, speed 4, WS-0. See (SL154.46).

DD *Barb* enters on Turn #6 from any map edge but no closer than 20 hexes from the monster, heading at player's choice, speed max, WS-III.

**MULAKEE:** Set up in hex 4230. See (SL154.45).

**YEAR:** Players should select a year before setting up the scenario. This will define the availability of ships, refits, fighters, drone speeds, and other items. Y163 is assumed if no other year is selected, as that was the first known encounter with this monster.

**(SL154.3) LENGTH OF SCENARIO:** The scenario continues until all forces belonging to one side have been destroyed, captured, or have disengaged.

**(SL154.4) SPECIAL RULES**

**(SL154.41) MAP:** Use a floating map. The Gorn units can only disengage by being more than 50 hexes from the Mulakee.

**(SL154.42) SHUTTLES AND PFs:** All shuttles and PFs may have warp booster packs if the year selected for the scenario allows their use.

**(SL154.421)** No ship in this scenario is qualified to carry an MRS shuttle, but in a variant of the scenario where that is possible, they may be purchased [up to the limits in (J8.5)] under (SL154.431).

**(SL154.422)** If fighters are used, and if using EW fighters (assuming the year allows their use), use the standard deployment patterns (one EWF for each squadron of eight or more fighters).

**(SL154.423)** There are no PFs in this scenario.

**(SL154.43) COMMANDER'S OPTION ITEMS**

**(SL154.431)** Each ship can purchase additional or special equipment as Commander's Option Items (e.g., T-bombs, extra Marines, etc.) up to 20% of its Combat BPV. See (S3.2) for details and exceptions.

**(SL154.432)** There are no drones in the basic version of this scenario. In a variation where drone using ships are used, all drone speeds and types are available subject only to the year selected for the scenario. Note that speed upgrades do count as part of the BPV to purchase a force in a variation.

Each drone-armed ship can purchase special drones up to the historical racial percentages as part of the Commander's Option Items. Note that (S3.2) allows drone ships extra points for this purpose.

**(SL154.44) REFITS** are as defined in the basic set up. In a variation the player can determine the refit status of his ships subject to the year selected and his available BPV.

**(SL154.45) THE MULAKEE:** The Mulakee is a life-form which appears to ingest munitions; it is apparently able to detect the presence of munitions, at least in large quantities, on ships.

**(SL154.451) MOVEMENT:** During the Speed Determination Phase of every turn, roll one die to determine the Mulakee's speed for the turn on the following table:

DIE ROLL	SPEED
1-2	Speed 10
3-5	Speed 20
6	Speed 30

If the closest ship is more than 10 hexes from the Mulakee, add one to the die roll. A roll greater than six is treated as six. The Mulakee has a turn mode of one at all speeds.

**(SL154.452) TARGETING:** Assign each of the freighters a number from one to six, with each freighter having its own individual number (e.g., there can be only one freighter with the number one). After the Speed Determination Die Roll in (SL154.451), roll a second die to determine which ship the Mulakee will attack.

DIE ROLL	RESULT
1-3	Roll again. The Mulakee attacks the freighter with that number.
4	The Mulakee attacks the tug.
5	The Mulakee attacks the ship with the most cargo boxes remaining.
6	The Mulakee attacks the ship with the most warp boxes.

Note that the Mulakee does this at the start of every turn, and in the middle of turns as indicated in (SL154.453), and may pursue the same or a different target on a subsequent turn. If the determination indicates that the Mulakee is to pursue a ship which has already been destroyed, roll again until a valid target is selected. In all cases, if two or more ships qualify, the Mulakee will attack the closest one; if two or more ships are equally close, assign a number to each one that qualifies and roll a die to determine which one the Mulakee attacks.

**(SL154.453) ATTACKS:** Each turn the Mulakee will pursue a target selected in (SL154.452) at the speed selected in (SL154.451) as if it were a seeking weapon. If the Mulakee enters the same hex as its target, it attacks a random shield (roll a die and the Mulakee attacks the shield corresponding to the number rolled on the die) in segment (6D). The damage inflicted is determined by the following table:

DIE ROLL	DAMAGE
1	24
2	20
3	18
4	14
5	12
6	10

Once the Mulakee has attacked a target, on the next Impulse before movement, roll under (SL154.452) to select a new target to be pursued.

**(SL154.454) OTHER ATTACKS:** Every impulse during the Direct-fire Weapons Segment (6D), the Mulakee will attack the closest single object closer than 4 hexes to itself. This attack will score an amount of damage equal to one die roll on the shield facing the Mulakee. If the closest object is in the same hex as the Mulakee, a random shield selected by rolling an additional die will be damaged. If the shield facing is ambiguous, select between the two shields by assigning one even numbers, and the other odd numbers, and rolling a single die. If two or more objects qualify as being closest, the Mulakee will apply this damage to one by the following order: tug, destroyer, large freighter, small freighter, shuttle. If two or more targets meet the priority, e.g., all three large freighters are at 2 hexes range, select one by rolling a die. The monster can never attack the current target selected under (SL154.452) with this system.

**(SL154.455) KILLING THE MULAKEE:** Accumulate 400 points of lab information (G4.1), and roll under (S6.1) to determine how to destroy the monster.

**(SL154.456) OTHER RULES:** The Mulakee cannot be boarded, tractorred, displaced, or placed in stasis. No ship with munitions aboard can escape the monster by sublight evasion. The Mulakee is a size class 1 living monster.



**(SL154.46) CONVOY:** The tug and freighters are moving as a convoy. No ship may leave the convoy until at least three ships have been crippled or destroyed. Until this happens, all uncrippled ships must remain within 3 hexes of all other uncrippled ships. Once three ships have been crippled or destroyed, the Gorn ships are no longer under this restriction.

**(SL154.5) VICTORY CONDITIONS:** At the end of the scenario, count the number of cargo boxes and add the number of crew units remaining (including the crew of the destroyer); refer to the table below:

CARGO AND CREW	LEVEL OF VICTORY
265+	Astounding Victory
245-264	Decisive Victory
225-244	Substantive Victory
205-224	Tactical Victory
185-204	Marginal Victory
165-184	Draw
145-164	Marginal Defeat
125-144	Tactical Defeat
105-124	Brutal Defeat
85-104	Crushing Defeat
84 or less	Devastating Defeat

**(SL154.6) VARIATIONS:** The scenario can be played under different conditions by making one or more of these changes:

**(SL154.61)** Replace the Gorns with a convoy of any other race by retaining the freighters and replacing the tug with a transport/non-combat tug of the selected race and a size class 4 ship of 68 BPV or less.

**(SL154.62)** Add a Mulakee to a base assault scenario. This should only be done in campaigns as a random factor as it can seriously detract from the value of the attacker's suicide freighters.

**(SL154.7) BALANCE:** The scenario can be balanced between players of different skill levels by one or more of the following:

**(SL154.71)** Increasing the amount of lab information needed under (SL154.455) before you can roll under (S6.1).

**(SL154.72)** Increase the BPV available for the ship which arrives on Turn #6.

**(SL154.73)** Add refits to the tug.

**(SL154.8) TACTICS:** Launch all the shuttles for information gathering; this will double your lab capability. Use a control space on each freighter as a lab. Use the tug's probes. Work up to speed 10 as soon as possible and immediately turn away from the monster. Use side slips and turns to keep the rest of the ships away from the current target. Once the monster catches your convoy, turn toward your shuttles to give them better information rolls. Shuttles should not be closer to the Mulakee than range 5 unless a ship is also in range, as they will start being destroyed quickly if they are targeted, at least have them together in the same hex so that no one shuttle gets too much attention as you NEED the information they can provide you. If you need a suicide shuttle to destroy the monster, let the destroyer provide it. Remember to score as close to 50 points of damage as you can in case it will help kill it (S6.1). Pray (or appropriate similar action) the monster does not move speed 30! If the convoy is shattered, have the ships head for deep space. Do not hang together after you no longer have to since killing the monster gains you nothing over saving the cargo.

**(SL154.9) PLAYTESTER COMMENTS:** Keep the DAC handy. With the monster's ability to change targets and attack every impulse, you will need it. This is a very busy scenario as you have seven ships, ten shuttles, and a monster who will do

something every impulse once it is in range. Good scenario to learn how to handle multiple units without the pressure of a live opponent.

**HISTORICAL OUTCOME:** The Mulakee ate well that day. Only the tug escaped, and only after jettisoning its cargo pod.

**(SL155.0) HOTTER THAN BLAZES**

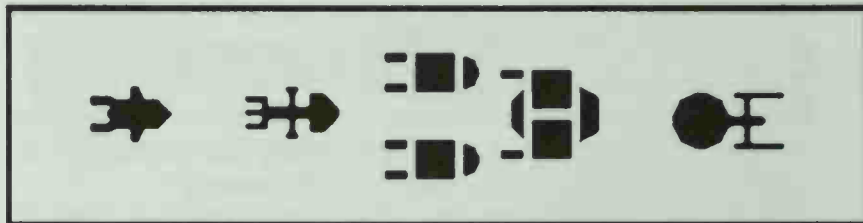

(Y164)

by Michael LaBossiere, Maine

In Y164, the Galactic Survey Cruiser *Discovery* was conducting scientific research in a heat zone located in the Klingon-Federation Neutral Zone near the edge of Kzinti space (the Federation would, of course, never use this as an espionage opportunity) when something unexpected happened.

The *Discovery* picked up a Kzinti distress call which reported a small convoy in the neutral zone being shadowed by a powerful Orion group. The *Discovery's* commander answered the Kzinti convoy's call and advised them that if they could make it into the heat zone he would assist.

The Kzinti convoy commander accepted *Discovery's* offer as there were no Kzinti ships nearby; it was that or risk the entire convoy falling to the Orions.

**(SL155.1) NUMBER OF PLAYERS:** 3; the Federation player, the Kzinti player, and the Orion player. Alternatively, one player could play both the Federation and Kzinti forces.

**(SL155.2) INITIAL SET UP**

**TERRAIN:** Set up two maps initially; the border between the two maps marks the edge of a Heat Zone (P10.0). The 42xx edge of Map #1 is adjacent to the 01xx edge of Map #2.

**FEDERATION:** GSC *Discovery* in 2415 on map #2, heading E, speed max, WS-III.

**KZINTI:** Pol *POL63* in 1619 on map #1, heading B, speed 12, WS-III.

Large freighter in 1823, small freighters in 1925 and 1623, all on map #1, heading B, speed 12, WS-III.

**ORION:** CR *Los Insurgentes* in 0403 on map #1, heading C, speed max, WS-III.

**(SL155.3) LENGTH OF SCENARIO:** The scenario continues until all forces belonging to one side have been destroyed, captured, or have disengaged.

**(SL155.4) SPECIAL RULES**

**(SL155.41) MAP:** Use a floating map. The "border" of the Heat Zone will need to be tracked in case any ship moves back into the clear, but ships moving in directions B or C will only get deeper in the zone. Ships moving in direction E or F may eventually move back into the clear. The Federation units can only disengage in directions B or C. The Kzinti units can only disengage in directions A or F. The Orion units can only disengage in directions D or E. Units which disengage in unauthorized directions or areas are considered destroyed.

**(SL155.42) SHUTTLES AND PFs:** No shuttles or PFs have warp booster packs.



(SL155.421) MRS shuttles may be purchased [up to the limits in (J8.5)] under (SL155.431).

(SL155.422) There are no fighters in this scenario. In a variant in which fighters are present, use the standard deployment patterns (one EWF for each squadron of eight or more fighters) for EW fighters if desired.

(SL155.423) There are no PFs in this scenario.

**(SL155.43) COMMANDER'S OPTION ITEMS**

(SL155.431) Each ship can purchase additional or special equipment as Commander's Option Items (e.g., T-bombs, extra Marines, etc.) up to 20% of its Combat BPV. Civilian freighters cannot purchase Commander's Option Items. See (S3.2) for details and exceptions. Note that whatever is spent here counts in the Modified Victory Conditions (S2.2) [Orions (S2.22)] as victory points for the enemy.

(SL155.432) All drones are "slow," i.e., speed-8. Type-II and type-V drones (speed 12) are available for purchase as special drones.

Each drone-armed ship can purchase special drones up to the historical racial percentages as part of the Commander's Option Items. Note that (S3.2) allows drone ships extra points for this purpose.

(SL155.44) REFITS: At the time of this incident, none of the units involved had been refitted in any way.

(SL155.45) OPTION MOUNTS: Orion Option mounts must be filled with weapons that are available to the Hamilcar Cartel (R8.1).

(SL155.46) FEDERATION: The Federation ship is not required to remain in the Heat Zone, but it must disengage if it receives more than 20 internals.

(SL155.5) VICTORY CONDITIONS: Use the Modified Victory Conditions (S2.201). If the Federation and Kzintis are played by two different players, points are scored separately for each one but their combined score is compared to the Orions to determine if the Orions won. The Orions gain no points (and the Federation/Kzinti lose no points) for freighters which successfully disengage.

(SL155.6) VARIATIONS: The scenario can be played again under different conditions by making one or more of the following changes:

(SL155.61) Move the action to the Federation/Gorn border, replacing the Kzinti police ship with a Gorn police FF.

(SL155.62) Change the Heat Zone (P10.0) to a Radiation Zone (P15.0).

(SL155.63) For a smaller and faster battle, replace the GSC with an FFS, delete the Kzinti Pol, and reduce the two CRs to a single LR.

(SL155.7) BALANCE: The scenario can be balanced between players of different skill levels by one or more of the following:

(SL155.71) Change the Pol to a CL.

(SL155.72) Replace one of the CRs with an LR.

(SL155.73) Add a refit to one or more ships of one side.

(SL155.74) Replace one or more of the freighters with phaser-armed versions.

**(SL155.8) TACTICS**

**ORION:** Double the engines, and deal with the escort before the Federation ship can help the convoy. Capture as many freighters as you can. Then head them off the board.

**KZINTI:** Head for the Federation ship as fast as possible. Use T-bombs and drones and a scatter-pack to try to damage the Orions.

**FEDERATION:** Head for the convoy at maximum speed. As soon as you are close enough, jam the Orions with offensive

EW to try to make their weapons less effective. Use scatter-packs and an MRS shuttle (if you have one) to have maximum drones on the board. Loan the Kzinti police ship EW if it is still alive.

**HISTORICAL OUTCOME:** The Kzinti police ship was destroyed, but the Federation ship managed to deny the Orions their sought after prize. After dueling with the Federation ship briefly, the Orions broke off to search for easier game.

**(SL156.0) SLUGFEST**



(Y185)

by Steven Paul Petrick, Texas

In Y185, the Klingon High Command sent the D5DX *Dark Spirit* on a bombardment mission against the Federation. The mission was successfully completed, and with its cargo boxes empty, the *Dark Spirit* began its return to base. While en route, the *Dark Spirit* detected a Federation raiding force heading for an asteroid field. The Federation had been eliminating surveillance sites in the zone, and the captain of the *Dark Spirit* realized that the raid must be directed against the last listening post in the sector. With that post gone, it would be necessary for the Klingons to maintain a scout ship to cover the sector until it could be replaced. The captain of the *Dark Spirit* saw no choice but to interpose his ship until help could arrive.

(SL156.1) NUMBER OF PLAYERS: 2; the Federation player and the Klingon player.

**(SL156.2) INITIAL SET UP**

**TERRAIN:** The map is an asteroid field (P3.2).

**FEDERATION:** DGX *Buford* in 4203, FFX *Ralph Hayles* in 4201, both heading E, speed max, WS-III.

**KLINGON:** D5DX *Dark Spirit* with two G1 PFs on mech links in 0730, heading A, speed max, WS-III.

(SL156.3) LENGTH OF SCENARIO: The scenario continues until all forces belonging to one side have been destroyed, captured, or have disengaged; see (SL156.45).

**(SL156.4) SPECIAL RULES**

(SL156.41) MAP: The map is fixed; it does not float. Any unit leaving the map has disengaged and cannot return. The Federation units can only disengage in directions B or C. The Klingon units can only disengage in directions E or F. Units which disengage in unauthorized directions are considered destroyed.

(SL156.42) SHUTTLES AND PFs: All shuttles and PFs have warp booster packs.

(SL156.421) No ship in this scenario is qualified to carry an MRS shuttle, but in a variant of the scenario where that is possible, they may be purchased [up to the limits in (J8.5)] under (SL156.431).

(SL156.422) There are no fighters in this scenario. In a variant in which fighters are present, use the standard deployment patterns (one EWF for each squadron of eight or more fighters) for EW fighters.

(SL156.423) The two G1 PFs carried by the D5DX are standard G1 PFs.



**(SL156.43) COMMANDER'S OPTION ITEMS**

**(SL156.431)** Each ship can purchase additional or special equipment as Commander's Option Items (e.g., T-bombs, extra Marines, etc.) up to 20% of its Combat BPV. See (S3.2) for details and exceptions

**(SL156.432)** All drones are "fast," i.e., speed-32.

Each drone-armed ship can purchase special drones up to the historical racial percentages as part of the Commander's Option Items. Note that (S3.2) allows drone ships extra points for this purpose.

**(SL156.433)** Prime Teams (G32.0) are not available in this scenario.

**(SL156.44) REFITS:** The Klingon G1s have the shield refit. There are no other refits applicable to units involved in this scenario.

**(SL156.45) TIME:** The Klingon ship in this scenario is fighting for time. Before the scenario begins, the Federation player places 12 counters, two each numbered 7, 8, 9, 10, 11, and 12, into a cup. The Klingon player draws one counter at random. The number drawn is the number of turns the Klingon player must fight the Federation ships to successfully stall them, e.g., if an 8 is drawn, the Klingon must fight the Federation ships until Turn #8. At the end of the turn number that the Klingon player drew, he must show the counter to the Federation player. The Federation player must disengage from the map before the end of the second subsequent turn, or his ships are considered destroyed, e.g., if an 8 was the counter drawn, the Federation ships must disengage by the end of Turn #10.

**(SL156.46) LISTENING POST:** After the asteroid field has been set up (P3.2), the Klingon player numbers each asteroid counter publicly for the Federation player. The Klingon player then determines the location of the listening post (a small ground warning station) by placing counters numbered 1-18 in a cup [this is separate from the drawing in (SL156.45) above] and drawing one at random. The number drawn is the location of the listening post, which is on a large asteroid. This station initially uses Hidden Deployment (D20.16).

**(SL156.47) DRONE STORAGE:** The Klingon D5DX has previously completed a drone bombardment mission and has no drones in its cargo storage. It does, however, have the standard drone loadouts for its drone racks, including the three reloads. It also has the drone storage in (K2.653) of non-X drones for its PFs.

**(SL156.5) VICTORY CONDITIONS:** If the Federation finds and destroys the station and disengages, he wins. If the station is not destroyed, the Klingon wins.

**(SL156.6) VARIATIONS:** The scenario can be played again under different conditions by making one or more of the following changes:

**(SL156.61)** Replace the Federation ships with a Kzinti CMX with two standard Needle PFs on mech links.

**(SL156.62)** For a smaller and faster battle, use an FSX with one G1 PF for the Klingons and only use the FFX for the Federation.

**(SL156.7) BALANCE:** The scenario can be balanced between players of different skill levels by one or more of the following:

**(SL156.71)** Change the Federation DGX to a DDX.

**(SL156.72)** Replace the D5DX with a D5X.

**(SL156.73)** Delete a G1 PF from the Klingon side.

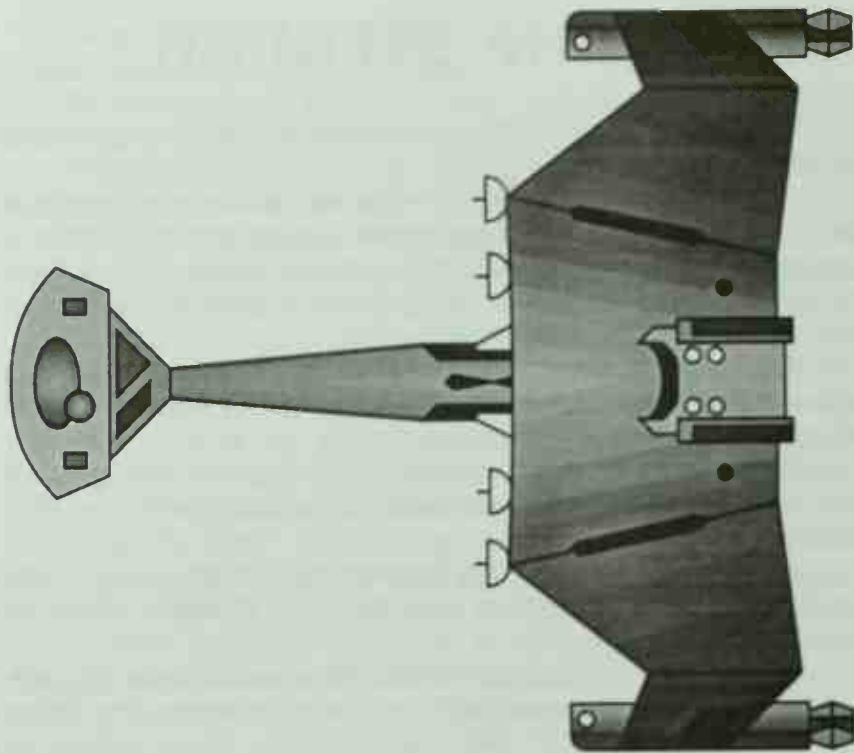

KLINGON D5DX

**(SL156.8) TACTICS**

**KLINGON:** Try to decoy them away from the real site by hanging around someplace other than where the station is. If that does not look like it will work, see if you can split them up and kill them one at a time.

**FEDERATION:** Consider splitting your forces to search faster, but keep an eye on the Klingon if you do. He has enough fire power to crush one ship if you do not keep together. You just do not really have a lot of time here, so get the job done and get out.

**HISTORICAL OUTCOME:** After an inconclusive battle, all of the ships disengaged with minor damage.

**PLAYTESTER LIST**

**BATTLE GROUP CALIFORNIA II:** Mike Stoker, Steve Dolcater, and Arnold Clarke.

**BATTLE GROUP CALIFORNIA:** Jake Whitmore, Wilbert Melton, Bill Janewicz, Tom Morton, John DeLaCruz, Jason Bell, Michael Urich, Joshua Marks, Jeremy Marks, and Melvin Vaughn Jr.

**BATTLE GROUP CINCINNATI:** Mike Filsinger and Kyle Marcroft.

**BATTLE GROUP COLORADO:** Scott Moellmer, Pat Moellmer, Craig McRae, Brian Davies, Dave Dupriest, Mike Raehal, Mark Bochinski, Dan Hoffacker, John Bowers, and Tony Knight.

**BATTLE GROUP ILLINOIS II:** Cliff Yahnke, Lysander Lysandron, Jon King, Bill Miller, Alex Pundy, and Andrew Pundy.

**BATTLE GROUP ILLINOIS:** John Berg, Mike Incavo, Dave Slavik, and Randy Demsetz.

**BATTLE GROUP INDIANA:** Tony Zbaraschuk and Jim Moran.

**BATTLE GROUP KENTUCKY:** Michael E. Stiles, Matthew E. Stiles, and Jamison E. Stiles.

**BATTLE GROUP LOS ANGELES:** Ray Olesen.

**BATTLE GROUP ST LOUIS:** Gregg Dieckhaus, Allen Phelps.

**BATTLE GROUP WISCONSIN:** Ken Burnside, Ken Rotar, and Mike Greenholdt.

**FORT IRWIN STAR FLEET GARRISON:** Jon Cleaves, Spence Cocherl, Marc Lago, and Bryan Hamilton.



## THE X-SHIP SEMINAR

The class fell silent as the Captain entered the room and walked to the podium.

"Good morning, cadets," the Captain said as he strode to the podium. "As you know, prototype X-ships entered service a few years ago, and X-ships are now becoming important force multipliers in the fleet. Who can give me a general definition of what an X-ship is? Cadet Jimerson."

"An X-ship is a command cruiser that has had its combat power enhanced to roughly dreadnought level by the addition of advanced technology," Jimerson offered.

"Accurate but imprecise, Cadet," the Captain responded. "I was not asking about X-cruisers, but about X-ships. Cadet Bookter?"

"A ship whose technology is advanced further than ordinary ships, also more expensive but far more effective," Bookter responded.

"Indeed," the Captain assented. "Now, we all know the various technological improvements and need not waste time listing them. What is the proper role of an X-cruiser, the largest of the X-ships? Cadet Burnside?"

"To command either a fleet of conventional ships, or to lead a squadron of X-ships, such a squadron being capable of faster strategic speeds. The latter doctrine will be required as X-ships become more and more common," Burnside said.

"Required?" the Captain asked. "Do you really think that so many X-ships will be built that conventional fleets cannot accommodate them? Do you know the commander of a conventional fleet who would be willing to do without one? Would it not be more precise to state that X-squadrons will be POSSIBLE rather than required?"

"They will be required," Burnside began hesitantly, "in the sense that an X-ship squadron can out maneuver conventional squadrons and that an X-squadron will be needed to counter that threat. We cannot assume that we will be the ONLY nation to deploy enhanced technology designs, sir."

"So you would say that once any race deploys an X-squadron, all must do so?" the Captain asked.

"Yes, sir."

"Does anyone disagree? Cadet Ramey?"

"X-squadrons can be countered without resorting to another X-squadron," Ramey insisted. "By using a network of pickets and scouts and two carefully positioned intercept squadrons, it should be possible to force an X-squadron to accept battle."

"You are willing to sacrifice pickets?" the Captain asked with mock horror. "Who will you select for this duty? And how will a squadron flagship command twice as many ships as it was designed to control. And there is another aspect that you missed. Cadet Burnside?"

"Scouts," Burnside began, "an X-squadron has to have a scout to find its targets, and that scout will give it enough warning of your approach that its superior maneuverability will make forcing it to battle all but impossible."

"So, only X-ships can counter X-ships," the Captain said with feigned solemnity. "There would seem to be flaws in this argument. Cadet Butler, what is one disadvantage of an X-ship, or a policy of building X-ships?"

"While the tactical advantage of an X-squadron is beneficial to any race," Butler explained, "the economic cost of building them becomes a factor. The current cost of a CX is approximately 40-50% more than a conventional cruiser. We could build dreadnoughts for the same price."

"Cadet Jimerson," the Captain shifted targets, "what is another common fallacy of X-ships?"

"X-captains might make the mistake of thinking their high-tech ship will allow them to easily roll over their opponents," Jimerson said. "What they forget is that even though they possess the firepower of a bigger ship they still have only the internal fortitude of a smaller ship. A CX has dreadnought firepower but simply cannot sustain the damage that a dreadnought can."

"Cadet S'Ketcm, can you cite another foible of X-ships?"

"The teschnology iss new and hard to maintain," the Gorn exchange student hissed. "The cosst iss high, but the cosst of not having them is alssso high. When they become more numerouss, every nation must have them."

"They're too expensive to use in frontal assaults," Cadet Bookter interrupted. "It is better to use them for special missions to destroy key targets. Despite their power, they are too valuable to risk unless they greatly overwhelm their target."

"Does anyone else have an observation on the drawbacks of X-ships?" the Captain asked.

"Power," Brynkhal, the Andorian cadet, declared. "Despite the popular misconception, X-ships do not have an infinite amount of power. Once their batteries are drained, they are little more than over-gunned standard ships."

"While their heavy weapons can be cycled more quickly," Cadet Butler noted, "they can malfunction."

"They take longer to repair except at bases specially fitted for their needs," Cadet Reineke observed, "and those special bases are not everywhere. This imposes a limit on their strategic mobility. They can get places where they cannot be maintained."

"There are never enough of them," Cadet Fridenberg said.

"They are difficult to use to their fullest when combined with non-X ships," Cadet Cookson insisted.

"Why is that so, Cadet?" the Captain snapped.

"Speed," Cookson explained. "The non-X ships are slower and hold back the X-ships, or the X-ships separate themselves from their slower consorts and become vulnerable."

"Indeed?" the Captain asked. "Could not an X-ship, which we have noted is still limited in power, simply cruise at a common fleet speed and use its surplus power for offensive purposes?"

"Yes, it could," Cookson admitted, "but then its superior weapon abilities are not fully utilized, sir."

"Indeed?" the Captain asked again. "Then it would seem that ANY ship can only use its weapons to maximum effect by slowing down."

"Even when doing so," Cookson insisted, "X-ships will cruise at higher speeds."

"But you forget," the Captain chided, "that X-ships can, and to be used to maximum effect must, overload their phasers, and this will put them at a common speed with non-X ships."

"Just the point," Cadet Ramey interrupted. "An X-ship is better to have in the fleet than a dreadnought because its overloaded phaser can more easily deal with PFs and fighters."

"Indeed," the Captain said, smiling faintly as the class groaned at the overused word. "Moving into the main area of our discussion, X-ships may encounter non-X ships either as part of a mixed fleet battle or in an X-vs-non-X battle. What conditions define how the X-ships will engage? Cadet Bookter?"

"X-ships should use their superior maneuver and firepower to fullest advantage, which isn't as simple as it sounds. They must use their maneuverability to put themselves at a point where they can deliver a killing blow without taking one. Since they have more firepower and tougher shields, this is easier than with a non-X ship."

"Cadet S'Ketcm," the Captain asked, "how would you use an X-ship's superior mobility and firepower?"

"Ssround him," the Gorn cadet insisted.

"How?" the Captain demanded.



"Trap the enemy between the Xs-ships and your main force," S'Ketcn grinned, clapping together his hands with the claws extended. "He will be crushed."

"Where is the best position in a mixed fleet for the X-ships?" the Captain asked.

"In the rear of your fleet," Cadet Chochrek replied without being called. "They will form a fast-moving force to exploit opportunities and to respond to any emergency."

"I disagree," Cadet Burnside broke in. "The X-ships should be in the center, where their aegis systems can defend the entire squadron from seeking weapons. If the enemy tries to attack it, he is attacking into your strongest point."

"What if you do not have enough X-ships to form a strong attack force?" the Captain asked.

"Pair up the X-ships with the fastest of the recent warships," Cadet Frazier responded. "War destroyers."

"And what units, in a mixed-fleet battle, should the X-ships be assigned to attack?" the Captain asked. "Cadet Reineke?"

"The key strategic ship," Reineke answered. "This varies depending on the situation, but would usually be the enemy's flagship, scout, carrier, PF tender, or perhaps a tug. The 'key' ship is the one that the enemy cannot do without, the one that, once lost, makes their mission impossible."

"Sending a CX against a dreadnought is going to leave two wrecks," Cadet Frazier warned. "Better to use the X-ships to get into his formation or flank, knock out a key unit such as his scout, and then escape unharmed."

"X-ships are excellent at hunting cloaked ships," Cadet Butler noted. "Their improved sensors and power are a dangerous combination."

"X-ships do, of course, encounter other X-ships," the Captain noted, "both in duels, patrols, X-squadron vs X-squadron encounters, and in 'private affairs' in mixed fleet battles. What are key elements of such engagements?"

"He who has more reserve power should win!" Cadet Frazier stated to the riotous applause of the class.

"An X-ship has more reserve power," Cadet Ramey began. "They can use it to fire weapons, change electronic warfare levels, reinforce shields to spread hellbore or plasma damage, tractor objects, and overload their phasers."

"X-ships must pay far more attention to managing their reserve power," Cadet Butler interjected. "They have more, which means they use it more, which means it takes more power to refill those batteries."

"Correct," Cadet Cookson added. "The biggest error of an X-captain is to assume that the technology is a magic carpet that will cover any error and which doesn't require any planning to use. They assume that they don't have to work for their victories, and that just isn't true."

"They also have larger phaser capacitors," Cadet Reineke noted. "They can shoot more, but not if they start using overloads. When they do that, they run out of phaser energy as fast as any other ship."

"X-ships add an Orion flavor to standard tactics," Cadet Dyals spoke up. "The massive reserve power of an X-ship is like the extra power from Orion warp engines. It's great to have, but when you use it all up, you're in trouble."

At least it can be refilled and used when you want it," the Engineering cadet noted. "You don't have to use it all at once like the Orions do. They end up wasting a lot of power that way."

"And like the Orions," Cadet Schoon added, "they cannot afford to take much damage. A wounded X-ship attracts the attention of every enemy ship in the sector."

"Any general observations on X-vs-X tactics?" the Captain asked.

"Do not get too close!" Cadet Bookter warned.

"Why not?" the Captain asked. "Close is where those overloaded phasers have the most power."

"X-ships cannot afford to take damage," Cadet Bookter responded, "and close up is where you're going to get it."

"Standard tactics apply to X-vs-X battles," Cadet Chochrek insisted. "All of that X-stuff cancels itself out."

"Really?" the Captain answered with feigned shock. "You make no allowance for more effective weapons and more dangerous engagement zones?"

"It's still you against him."

"In an X-duel," Cadet Burnside broke in, "it's better to fight from middle distances and use the standard arming cycle. The fast-load cycle is too dangerous because of the misfires. X-seeking weapons are easier to stop, because of your defenses, and more devastating when the countermeasures fail."

"In an Xs-duel," Cadet S'Ketcn added, "there will be more rapid changes in speed and electronic warfare. A captain must be prepared to respond to the higher tempo."

"X-ships are more vulnerable to hit-and-run raids than non-X ships," the Marine cadet added. "Once their shields are down, every system destroyed costs them a higher fraction of their capability."

"The advanced-technology ships represent the cutting edge of naval warfare," Cadet Cookson noted. "In one or two decades they will be the standard and much more available and common. Then a new edge will be found and tactics will continue to evolve, much like the early cruisers were phased out by current designs, and much as the hot-warp 'war' classes have made the smaller ships obsolescent."

"That's all of our time for this class," the Captain said, stopping the discussion. "I have arranged a simulator exercise involving X-ships. It begins now. This way, please." ★★★

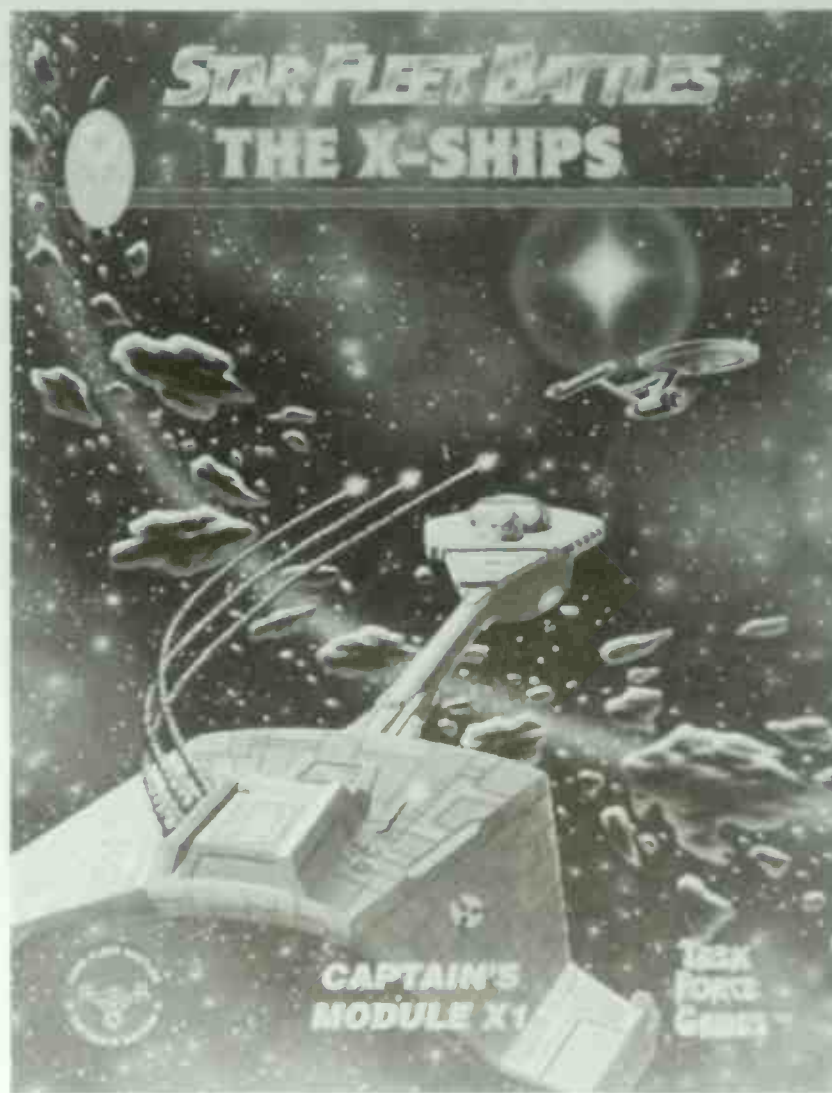



## TERM PAPERS

### NEW STRINGS FOR THE YO-YO

— *Ensign Gary T. Langtimm, USS Idaho*

With the introduction of Offensive Electronic Warfare, those ships fighting Klingons equipped with Stasis Field Generators have a new and powerful ally. Stasis-equipped ships are required by (G16.3512) to retain a positive lock-on to keep their prey in stasis. Offensive Electronic Warfare can force these ships which are already power exorbitant to roll for a separate lock-on to each of their target ships or expend 6 points of ECCM (or have their own scout lend them 6 points of ECCM). In addition, because a Stasis Field Generator ship cannot leave its hex, your scouts can control the range to ride the edge of 15 to 16 hexes to alternately drop and recover the Offensive Lending (G24.2121). This will force the Stasis Field Generator ship to make multiple rolls to retain its lock-ons without having to allocate any more power. Note that under (G16.33) you can force the Stasis Field Generator ship to waste 15 points of power by forcing the release of his first field before any new fields can be created.

When trying to anti-stasis yo-yo a Stasis Field Generator ship that is trying to protect one of its own ships, do not wait for the last/best opportunity impulse to do so as your advantage lies in the number of die rolls you can force. The stasised ship, if released, will still be under the effects of disrupted fire control for four impulses and cannot be placed in stasis again for eight impulses. It would not have been placed in stasis if the situation were not critical. Having a scout able to apply Offensive Electronic Warfare to ships hunting for a cloaked unit can be a real lifesaver. Use it to prevent the enemy from gaining that critical lock-on to anchor your cloaked units, or to reduce the effect of their seeking weapons targeted on the cloaked unit. This is particularly useful for a base supporting defending cloaked ships as a scout in open space would probably simply become the primary target if it tried this.

*Rated the Best Term Paper in this issue.*

### JINDARIAN FRONTGRADE

— *Commodore Ken Burnside, USS Wisconsin*

The Jindarian asteroid ships, with their dispersed weapons mounts, have two firing arcs that are of paramount importance, the hex rows emanating from their #3 and #5 shields. While difficult to apply in a forward approach battle, these two arcs allow a Jindarian asteroid ship to concentrate 90% of its firepower over the course of a turn simply by running away from its tormentor and then turning to an oblique. By timing your turns properly, even with the awful asteroid ship turn modes, it is entirely possible to fire, turn, and have your second rail gun ready for defensive mode. This is, of course, a simple variation on the Kaufman Retrograde. As an added benefit, this course of action also maximizes the number of impulses that a seeking weapon or shuttle will be in the arc of the defensive mode rail gun.

### LETTING YOUR GUARD DOWN

— *Ensign Michael Mitchell, USS Georgia*

When flying a Lyran ship, sometimes it is to your advantage to drop your ESGs purposefully. Rule (G23.323) puts a 32-impulse clock on reactivation of a particular ESG from the time it is dropped. If you are in a situation where the ESG field has served its purpose (knocking down drones or stopping hell-bores, for instance) but still has some strength left, go ahead and drop it. You will shorten your cycle time before you can release it again, allowing you to get your ESG back on line sooner.

### ADD SPHERE — *Fleet Admiral Ray Olesen, USS California*

When using ADD-armed escorts, the most effective ADD range covers the same area as a 3-hex radius ESG. Each of the six sides is 5 hexes long. If defending against drone waves where the escorts are not the primary target, position your escort so that the drones come through the front of the sphere and continue down one side (this is easiest if they are moving down a hex-row) at the 3-hex range. Drones closer than 3 hexes receive the attention of your phasers. This maximizes the effectiveness of your ADDs and gives you maneuvering room in case some are targeted on the escort. If you exhaust your ADDs, then close in for more effective phaser work. While most escorts tend to be somewhat short of lab spaces to identify drones, they can use their aegis systems for this. Of course, the escorts should be arranged to also overlap each other so that they can fire ADDs to defend one another as well as the principle ship. This creates an overlapping and integrated defense.

### THE WEB TRAP

— *Captain Tony Zbaraschuk, USS Washington*

This trap needs two Tholian ships (or one with a web anchor). Have your two ships close on and enter the hex of a slow-moving cloaked Romulan. It is VERY IMPORTANT that neither they nor the Romulan be scheduled to move next impulse. One ship lays web. On the next impulse, nobody has moved and the other Tholian ship then reinforces the web to a strength of 1 or greater. The Tholian ships are then at point-blank range, and the Romulan's cloak is voided. The Tholians then fire everything at the Romulan. If they are really nasty (and have enough power), they can tractor the Romulan. Two Arachnid-Ws moving at speed 25 are probably the best ships for this; they can overrun any Romulan, and the rest of the PF swarm gets a chance to kill him.

Romulan countermeasures: Never let your cloaked ship get close to a Tholian. Frustrate their timing by maneuvering so that no Tholian enters your hex before an impulse during which you will not move. Disengage.

Note that this tactic requires very tricky timing. If pulled off, however (and if the Tholian ships have 6 to 8 points of power to spare for the web), the Tholians can turn off their web-pass gear and leave the Romulan ship trapped in a 1-hex web.

### SELECTIVE PHOTON OVERLOADING

— *Cadet Dave Steele, USS Colorado*

Most inexperienced Federation players (or other races who have borrowed the photon torpedo) forget that they have perhaps the most flexible heavy weapon in the game. The photon can be selectively armed for a yield of 8 to 16 damage points, in 1-point increments. But how often have you heard the phrase, "I could not get closer than range 6, and half my overloads missed"? A quick look at the charts shows that at range 5-8 you only have a 50% chance of a hit with each torpedo, but at range 4 your chances increase to 66.7% per torpedo (2/3rds).

Ah, but how to close to range 4? That is the question.

Consider this: at range 4, on the average, if you arm your torpedoes for a 12-point yield (6 points arming cost), you will statistically do the same damage as firing maximum yield 16-point torpedoes at range 5-8. You will, however, have saved 8 energy points that can be used for other things—like speed. If you are forced to fire from the 5-8 hex range bracket, you will have wasted less energy on misses. If you choose to hold your torpedoes until the next turn, the energy cost is less, only 1.5 points per torpedo. Additionally, if you achieve a good firing position, you could always increase the yield of your torpedoes to 14 by adding a point of reserve warp to each torpedo.



**THE SIXTH TAC** — *Cadet Ken Rotar, USS Wisconsin*

One often overlooked rule in the rulebook is devastating when used in a knife fight: (C3.33), which states that a ship moving at speed 1 (not using tactical maneuvers) can turn 60° and move directly forward. The tactic is to plot your full five TACs (four warp, one impulse), and a mid-turn speed change to speed 1 in reverse on Impulse #27, gaining a sixth 60° turn AND the ability to move (perhaps) onto a shield your opponent was not expecting.

**THE BEST DRONES**

— *Cadet Sebastian Chedol, HNLMS Holland*

I believe, unlike the rulebook, that the best drone for offensive battles is the type-IV drone with 1/2 space of internal armor. The point is that it is now impossible to ensure a kill with even two phaser-3 shots (you need two rolls of four or less which gives five chances in nine that the drone will survive), and only two phaser-1 shots will ensure a kill (a phaser-3 and a phaser-1 fired at the drone will still have one chance in eighteen of failing to kill it), effectively pressuring the target not to gamble.

And even with that 1/2 space of armor, the drone still significantly hurts the target, doing 18 points of damage. Most ships cannot afford to waste one phaser-1 and one phaser-3 per drone in order to kill them, so you will hit with more drones. Usually you launch drones only to have them blasted by minimal phaser firepower. This way you will probably get one to hit.

Kzinti ships get the best use of this (50% availability), and a quick combat check of the Kzinti battlecruiser versus a Klingon D7K with the Y175 refit shows that the Klingon could handle only four drones in this manner (assuming it got all the phasers to fire), while one phaser-1 has only one chance in six of killing such a drone. A typical Kzinti ship after Y175 could have 10 such drones in its drone racks at the start of a scenario and 20 more in reload storage.

Obviously, these drones are better in the rack and only after the Klingon has exhausted or lost his ADD rack. Against Lyrans they still carry their offensive punch after hitting the ESG and taking the damage (which they do better). Arranging for a Klingon to lose his ADD rack is fairly easy before you use this trick. Afterwards, he is going to keep the ADD rack around and use his regular drone racks for defense.

ISC ships will struggle more than ever to kill them. (They already have problems with drones. This makes it worse.) Andromedans are not a good choice with their T-bombs, but it is the only drone that two phaser-2s will not score an automatic kill on (except for better armored ones, of course). Given that tractors, MW drones, weasels, not to mention T-bombs by Klingon and Lyran ships are available, this is not an overwhelming alternative and will tend to use up the supply of available drones faster.

Klingons and the Federation can use these drones too, but not as well as the Kzintis.

**WAIT TO DISPLACE** — *Cadet Paul Stovell, HMS England*

By maneuver it is reasonably easy for ships with FH firing arcs to cross in front of their opponent and use a sideslip away to keep at the same range for a second consecutive impulse. If, as an Andromedan, you can arrange this, then do not declare displacement immediately, but do fire. With luck, your opponent will hold his fire thinking you are coming closer and thereby lose weaponry before he can use it. Other advantages may accrue. If at range 3 or less, hold a couple of phaser-2s back for a Mizia attack, and at range 5 or less use hit-and-run raids. A good target for hit-and-run raids is the batteries of the enemy ship, as you may then be able to displace behind an opponent no longer able to HET after you.

**DO NOT BELIEVE THE PROPAGANDA**

— *Lieutenant (JG) Jeffrey Zellerkraut, USS Alabama*

It has been noted in several places (the Tactics Manual especially) that Andromedans should intentionally damage their power absorber panels (by running into terrain, for example) if they need power. Do not believe it. Depending on the amount of damage received, the panel degradation will be two or three times the amount of power that will transfer to the batteries (in the first turn) without dropping the panels. When you multiply the degradation by two to find the total power spent to repair them, damaging your panels is not that efficient. If the situation is such that you could drop all panels to transfer the power within them to batteries (which you must do; panels filled to standard levels already do not need additional power), you either did not need to power them in the first place or were not expecting combat so weapons should not have been powered.

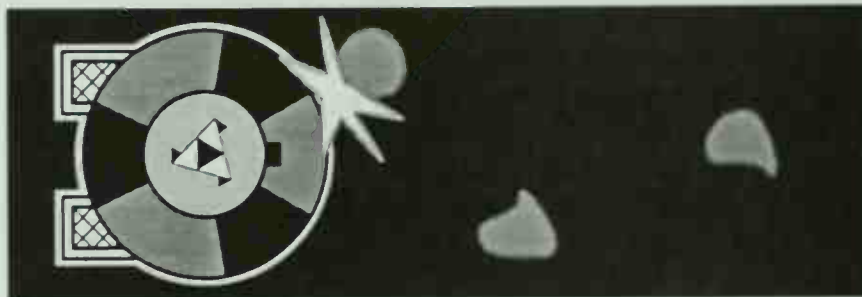
**BOOMERANG SEEKING WEAPONS**

— *Lieutenant (JG) David Coulthurst, USS Wisconsin*

Attacking a Tacing ship which has a highly reinforced shield can be frustrating. But a down or weak shield kept away from you will be vulnerable to a nasty trick.

Rule (F2.323) allows a seeking weapon launched in the same hex as the target in the direction opposite a down or weak shield to hit that shield if the launching ship moves out of that hex in that direction on the following impulse, as long as the target ship does not move. The huge potential for seeking weapon damage can make a range zero direct-fire overrun the least of the target's worries.

Plasma users will enjoy this tactic, as will Klingons and Kzintis who can launch drones in the hex followed by the phaser hose on the next impulse for maximum Mizia effects.

The attacker should approach the Tacing ship along the hex spine to force the Tacing ship to place the weak or down target shield in one of the three hex sides you can exit through. Skip the overloads and forward firing phasers (they will not get through his reinforcement alone anyway), and save the power for your own shield reinforcement and negative tractor energy. If you lose weapons on the way in, remember that your seeking weapons have already launched, you are not charging your heavy weapons, and your rear-firing phasers will be shielded by the phaser directional damage rule.

**ID THE DRONE RACKS**

— *Cadet David Brinson, USS Oklahoma*

Many players know to ask which plasma launcher launched a given plasma torpedo to see if that launcher launched a PPT. Few captains ask to know which drone rack launched what drone. This is useful in determining the drone rack launch rate if you do not know it. This is also useful in determining whether it launched a type-IV drone later on in the turn when you lab the drone. This is really useful in tournaments where the Kzintis only have four type-IVs.

Tracking drone launches is important, if for no other reason than to determine when the enemy might be out of drones. It is also important to track the turns that he did or did not launch a drone from a given rack, as that may indicate that he has reloaded it, or is unloading it.



**DON'T MISS THE BUS** — *Sr Lt Chuck Strong, USS Colorado*

How many times have you seen this happen: a player MIRVs his MW drone and does not leave the bus drone on the board. If you are fighting an ESG-armed opponent, allow it to continue toward the target as it could cause damage to an ESG field. Also, with type-I or -III MW drones, he might think that it is a two-space drone with an additional payload and may waste his efforts against it. This may also work against other non-ESG opponents. Of course, if the situation dictates, you may still need to drop the bus if you need the control channel.

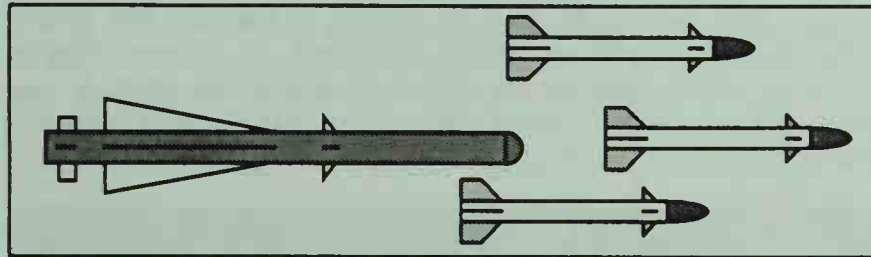
**DASTARDLY DRONES** — *Lt JG Bill Barsh, USS Michigan*

Shuttles are dangerous, especially to those races that do not have parity with their traditional enemies (Klingon, Kzinti, Romulan, and Lyran ships are all lacking). So how do you even things up? Well, the only way is to waste those pesky things. For drone users there is a rather nasty trick. Target a drone on an admin shuttle, but use a type-I that has a half-space internal armor module. This costs no points and is very effective. Just imagine the shuttle pilot's face when he hits the drone with his phaser-3 and it keeps coming. This may also work against fighters that carry phaser-3s. You may even get a free hit on a ship this way, but those have labs to detect your trick, so do not count on it.

**LYRAN PICK-A-SHIELD**

— *Ensign Donovan Willett, USS Alabama*

One of the unique characteristics of the ESG is that if used in a knife fight, any ship with maneuver equality or superiority can choose which shield to hit by choosing the radius and the appropriate turn. By enveloping the enemy and using a turn or HET, the non-facing shields can be hit. A small sphere and a sideslip or turn can hit any facing shields. This may prove useful when the enemy thinks he has his down shield where you cannot hit it.

**PF LAUNCH SPEED** — *Ensign Sam Clark, USS Ohio*

Rule (K2.321) limits the speed of a PF to a maximum of 15 for the first 32 impulses after undocking. Launching early may leave the PFs far behind the fleet, while launching late may allow your enemy to overtake them during a battle pass. One way to overcome this is to launch on Impulse #1 of your approach turn. Then tractor your flotilla with the rest of the fleet. The slight loss of speed (the PFs add a movement cost of 1/5 to each ship doing this) will be insignificant on the approach, but does allow the PFs to reach near maximum speed immediately on the next turn.

**TRACTOR-MIZIA-TRAP**

— *Fleet Captain Sandy S. Hemenway, USS North Carolina*

When using tractors for drone defense, try not to use all of your tractor capacity if you expect you will take damage before you can destroy them. If your tractor capacity is full and you lose a tractor beam when you sustain damage, then a drone will be released, hitting you and (if on a down shield) possibly destroying another tractor, repeating the process until you no longer have any tractors, or ship to speak of. It is also a good idea when possible to tractor drones so that they are not on the same shield to also lessen this problem.

**COUNTER-TRACTOR TACTIC**

— *Ensign Scott Fridenberg, USS Oklahoma*

If an opponent attempts to tractor you near the end of the turn (intending mayhem at the beginning of the next turn) and you feel you may not have the power to negate the attempt, consider letting him have it and tractoring him back. If he is determined to maintain the tractor, he may be unwilling to expend any of his tractor energy negating yours. At the start of the next turn when it is time for the tractor auction, allocate as much power as you can afford to negate his tractor while maintaining your own. During the Initial Activity Phase, you write down your Tractor Rotation moving him one hex away from you. If he neglected to rotate you one hex closer to him, you will be successful and you will have increased the effectiveness of your negative tractor energy, possibly breaking the tractor. You will also have gained an extra impulse to deal with any seeking weapons he may launch. If he has plotted to rotate you closer to him, you will at least have avoided that.

**FUNCTIONING IN REVERSE**

— *Cadet Russ Bullman, USS Illinois*

We all know about "kicking the tires" of a starship, but here is one thing to consider: Check and see if the ship can function in reverse. Most cannot effectively do so, but a surprising number can. A partial list of ships able to operate in reverse includes: Frax ships; most drone variants; scout variants; unarmed carriers and PFTs; and escorts that rely on drones, ADDs, or LS/RS weapons.

While fighting in reverse will never become standard practice, it can be a scenario saver if it keeps a ship with downed forward shields in the battle. Note that a Klingon ship that has lost its disruptors can operate in reverse and make a good drone buster by using its phasers. Fighting in reverse can also give you time to repair vital systems.

**FEDERATION DESTROYER TACTICS**

— *Lieutenant Commander Mike West Jr, USS Texas*

When using the Federation destroyer (especially without the refit), never overload the photons (unless you are starting the turn with a willing opponent next to you). First of all, this is because you cannot charge them. The other reason is because you already have twice the heavy weapons of any other destroyer in the game (especially before the war). This means that a full salvo of your normal loads will equal his overloads. The advantage of this (besides not having to spend the power to overload) is that your slower speed is no longer a critical handicap, because you can effectively shoot beyond 8 hexes. So now, if your opponent (e.g., a Klingon) wants to saber dance, you can let him fire (if it will not penetrate your shields) and shoot him in a flank shield as he turns off. If he does close range to use overloads, let him, since your normal loads will match his overloads, and your more powerful phasers will help toast him. Also, always save a phaser or two for defensive work (again, unless you can finish off your opponent). You have more phasers than he could dream about (you do have a full cruiser's complement), so it will not hurt your attack, and can save your life.

**ACE IN THE HOLE**

— *Commander Tom Chartoff, USS New Jersey*

When operating PFs, always discharge your batteries during Energy Allocation and refill them with reserve warp power. This allows you to use erratic maneuvers or perform an HET without having planned to do so during Energy Allocation. The points of reserve warp that allow you to go erratic or to HET can be worth their weight in gold (and save your skin) when an attack run goes sour.



**THE WARP TEASE (THE SHIP THAT CRIED WOLF)**— *Cadet Earl Cooley III, USS Texas*

An undetected ship (D20.0) should be ready to deploy in ambush when the opportunity arises. Before each turn, try to judge what impulse in the coming turn has the highest potential for ambushing the enemy, based on his speed, heading, and separation; then plot a mid-turn speed change for that impulse. You do not become eligible for detection by movement until you commit that energy to movement by actually announcing the speed change (D20.22). So, if the situation three impulses before your plotted mid-turn speed change does not warrant springing the ambush, announce Emergency Deceleration, making sure that the impulse of your plotted speed change occurs during the Post-Deceleration Period (C8.4). This gives you about 19 impulses to decide whether or not to ambush for that turn.

There are three benefits to this tactic: offensive, defensive, and psychological. Each turn, you will be ready to spring some sort of ambush if the time is right. If no ambush is warranted, the Emergency Deceleration gives you a bit of extra shield reinforcement in case you get discovered before you are quite ready. Finally, with plenty of impulses of leeway to time the Emergency Deceleration, you can choose an impulse for that announcement based on the psychological pressure on the opponent it would provide. You "tease" your enemy with the once-a-turn announcement, and eventually, the hidden "wolf" will attack.

**DIRTY DRONE TACTICS**— *Ensign Daniel Redys, USS Hawaii*

When launching large groups of drones at other ships, place some on a ballistic course (type-IIIs with multiple warhead and Starfish modules) targeted on shuttles and other drones. When they get to their release point (target hex), they will begin to search for targets of opportunity. In this way you protect your drone fleet against two of the more standard methods of drone defense: drone and fighter intercepts. Of course, you need to have a good idea where his fleet is going, or else the drones will diverge from the drones they are protecting.

**SPECIAL TERM PAPERS**

*These papers were not really tactics and cannot count for promotion points, but were so highly rated by the staff that we felt they should be published.*

William Sligh noted that if you want to be sure you can move during every impulse in the last part of the turn (without running into the problem with making an HET at high warp speed), you should plot speed 25 then change to speed 26 on Impulse #27.

Michael Toler pointed out that the best way to know how to kill an opponent's favorite ship is to playtest it against your own favorite ship. Find out its strengths and weaknesses; then tailor your operations to minimize those strengths and take maximum advantage of the weaknesses.

Several people have proposed color-coding your SSDs so it's easier to find the engines and weapons and everything else.

Robert Giacolono asked: Would you like to have the fighters on the SSDs of your pre-Module J ships? If you do, the answer to your problem is simple. If you have access to a copy machine with a zoom feature, photocopy the ship and fighters at a smaller scale (80-85%). Then all you have to do is cut the copies apart and tape them on a standard sheet of paper. Keep this as an original and copy as many as you like. (*Such copying would still be within the permission given on each rulebook for your own personal use, but not for sale.*)

**ENCORE TERM PAPERS**

Encore Term Papers are additional papers by players who have already been selected once for publication in this issue, not papers that have appeared before.

**SNEAKY ENERGY ALLOCATION**— *Ensign Dave Steele, USS Colorado*

When playing an opponent who rebuilds your energy plot, consider using one point of energy from your batteries to hold a suicide shuttle. Make your first turn's plot easy to read so that your opponent will "know" that you "cannot" be holding a suicide shuttle. If your opponent is convinced that the shuttle you just launched is only a phaser-3 platform, its chances of closing (or his overrunning it to make killing it easier) increase significantly.

**JINDARIAN ECHELON**— *Commander Ken Burnside, USS Wisconsin*

A very effective tactic for the Jindarians to use is to form up an echelon, with their smaller asteroid ships up front to provide defensive rail gun fire, while the larger ships in the rear rows concentrate fire on one target. This minimizes the chances of any fighters or seeking weapons making it into the rear rows, and the smaller asteroid ships can still take an impressive amount of punishment. The slower speeds of the Jindarians can be greatly mitigated by the use of this tactic.

Rail guns on the gunline ships should be fired in offensive mode near the end of any given turn if there is no seeking weapon or fighter threat that can approach the force before the rail guns can be re-cycled up and ready to fire again. In the event that the seeking weapon threat forces the gunline to continue firing over a turn break, the Jindarian player must be ready to move his heavy ships forward over the smaller ships in order to provide continuous defensive coverage.

**WEB AND THE SCATTER-PACK**— *Ensign Ken Rotar, USS Wisconsin*

In tournament play (or in fleet battles) against a drone-using race, most of them will deploy their scatter-pack at extreme ranges (23 or more) to prevent its destruction from miscellaneous weapons fire. A counter to this tactic for the web-caster-armed Tholians is to use the web caster to create a one hex, strength 30 web on the hex the shuttle is in, timed to solidify before the drones would release. After the web is laid, the Tholian ship should try to get 36 hexes away from it, and thus beyond maximum tracking range. If the web is laid while the Tholian ship is at range 30 from the suspected scatter-pack, this is fairly easy to arrange, even on a tournament map.

**NOTES AND ADMINISTRATIVE CREDIT:**

This term paper section is shorter than usual, despite the larger issue, but that only means that the papers published here have a higher average score than ever before, and there are plenty of papers for next time!

Cadet Richard Van Alstyne is credited for an Andromedan tactic that exposed a rules loophole that has been fixed.

The term paper "Specialized PFs" by Marc Kicmol in CL#15 is technically incorrect. Under the provisions of (K2.114), you cannot put non-standard PFs on casual PFTs, although this is allowed in some conditions (e.g., published scenarios).

The term paper in CL#14 credited to Matthew T Kemps should be Matthew T Kepme.

Some asked why their ranks went *down* in CL#13. That's because those term papers were from the original Nexus issues, and the original ranks at the time they were first published were (appropriately) kept. ★★★



## X-SHIP TERM PAPERS

In keeping with our mini-theme on X-ships, we present this special selection of X-ship term papers.

### DRONE DEFENSE X

— *Captain Tony Zbaraschuk, USS Washington*

X-ships can provide powerful, in fact nearly total, drone defense for your fleet due to their combination of limited aegis fire control and overloaded phaser-1s fired in rapid-pulse mode. A typical X-cruiser can destroy 20 type-I drones per turn at range 1, not counting the effects of its own drone racks. With its high speed, the X-cruiser can easily maneuver to intercept incoming drone swarms. Most X-cruisers will have sufficient power to fire non-overloaded heavy weapons at the same time.

Smaller X-ships may be far more useful as drone killers (even as plasma killers) than as meaner versions of standard warships. Once the enemy has exhausted his drone supply without effect, your X-ships will lead the charge to destroy them.

*Rated the Best X-ship paper in this issue.*

### X-PHOTONS — *Cadet Michael Vinarcik, USS Michigan*

Photon-armed X-ships have considerable flexibility with their photons. While it is desirable to fire one standard load per tube per turn (avoiding those embarrassing ejections) instead of crash overloads, consider this: Arm half your tubes as one turn photons (standard loads); arm the other half as the first turn of a normal load (two points). If the enemy stays within the range bracket that favors proximity photons, finish arming the torpedoes with reserve power, proximity fuze them when arming is complete, and fire away! If the enemy closes, finish them as standards instead! This is a way to avoid being saddled with proximity photons in Energy Allocation and makes the most of the versatile photon.

### X-EW — *Ensign Bill Gary, USS America*

X-ships should allocate power for 4 points of ECCM which, combined with their natural 2 points, will always negate any ECM generated by the target. The target may go erratic, but can at best achieve only a shift of 1 since the X-ship can allocate a point of battery to have a net of 7 ECCM. Conversely, the X-ship should (unless it needs the preceding adjustment) always allocate 2 points to ECM since this might cause a shift for an enemy firing at them. Note that Orion ships with 2 points of built-in ECM, and some nimble ships, form an exception to this and should be dealt with on a case-by-case basis. By the same token, non X-ships should treat X-ships as essentially normal targets in an ECM environment, but not worry about ECM for themselves unless they intend to also use erratic maneuvers, in which case only 5 points should be allocated for ECM since that will result in total of 9 ECM, or a net shift of 1.

### X-PHOTON BARGAIN

— *Ensign Michael Vinarcik, USS Michigan*

When using a photon-armed X-ship, do not crash overload the photons. A full overload will double the damage, but you have a 50% failure rate, with a 1/6 chance of the tube not being available on the following turn. Standard load the torpedoes every turn, and you can always finish overloading them if a firing opportunity did not present itself.

However, if the enemy blunders within range 8, use some of the reserve warp to make 10-point overloads; there is no misfire chance, and you get a 25% increase in expected damage with only a 1/6 discharge rate.

*This is an encore paper, printed because of its high score.*

### PLASMA DECEPTION — *Cadet Michael Rogers, USS Kansas*

Normally, enveloping plasma torpedoes are revealed by their warhead strength. The doubled strength does NOT match any other torpedoes. With the introduction of X-ships, this situation changes. Enveloped plasma-G torpedoes and normal plasma-M torpedoes both have 40-point warheads. This allows X-cruisers an interesting deception. Launch both plasma-M torpedoes, and use the plasma-S torpedo launchers to launch enveloping plasma-G torpedoes. Your opponent may assume two real and two pseudo plasma-M torpedoes have been launched. This works especially well with multiple targets. Note: the rates of degradation are different for the plasma-M torpedoes and the enveloping plasma-G torpedoes. A careful opponent can discover this deception after the torpedoes have traveled far enough; however, not everyone constantly monitors warhead strength.

*They will also detect the deception by noting which tube launched which torpedo, but they might not ask for that. The problem is that to gain the payoff, the Ms must hit nothing and the plasma-Gs must hit something, like a weasel, where their enveloped status is not revealed and before they degrade.*

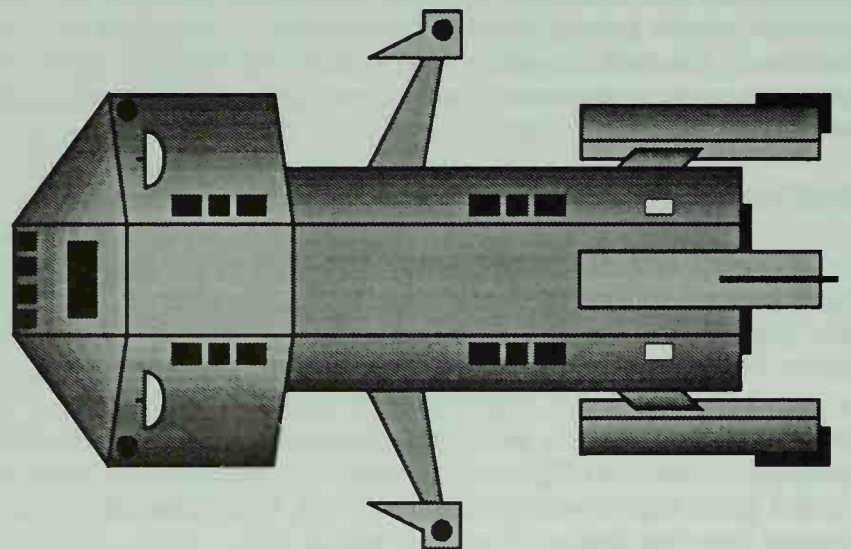

## SCENARIO TACTICS

We have established a special category of term papers that deal with tactics for a specific published scenario. You are welcome to submit your papers for this category. We have received very few scenario tactics papers, and it is a golden opportunity to get your paper published.

### CAVALRY RETREAT

— *Cadet Jeffrey L. Orsini, USS Missouri*

In (SH11.0) Cavalry Charge, the Alliance forces may look rather non-compatible at first glance, but they are ideally suited for a retrograde. On Turn #1 plot speed 0 for the entire fleet, with a change on Impulse #9 to speed 10 in reverse. While the Klingon drones (and ships) are trying to "climb uphill" toward the Alliance force, the drones and plasmas of the Alliance ships will be screaming downhill into the Coalition units. Note that you will only be paying for 8 hexes of movement on the first turn so that you will have a large amount of energy left for shield reinforcement, suicide shuttles, etc. For that extra bit of fun, purchase all the type-IVMW drones allowable. These will enable you to (effectively) pick off five Coalition drones with one Alliance drone, freeing your phasers and remaining drone stocks to use against the Coalition ships. You must make effective use of the HUGE Kzinti special drone allowances.



## TOURNAMENT PAPERS

This regular feature will focus on tactics for use in the SFB tournaments. Send your papers for this special section!

### CENTERING THE TOURNAMENT ANDROMEDAN

— *Ensign Warren Taylor, USS Georgia*

For most ships, disruptor ships especially, following the Andromedan into a corner for the initial alpha strike is a big mistake. The problem is getting him to meet you in the middle of the map. To do this, maintain a decent speed and make judicious use of counter-turns. Do not attempt to take the center of the map and wait for him to meet you there. You will find yourself out maneuvered and having to turn your back on him or follow him too far afield.

Rather, your goal should be to orbit the center of the map at about the same TIME-DISTANCE from the center of the map as the Andromedan. In other words, accounting for speed differentials, you should be about as far from the center (on the other side) as the Andromedan. This way, you never get too close, and you can turn in when he decides to stop wasting his batteries and attack you, meeting him in the center of the board.

If you have a scatter-pack, it is relatively useless against the fast-flying Andromedan. Deploy it fairly early, and form a drone wall of 3 or more hexes. Use this to influence his maneuvering as much as possible. It should make your job of maneuvering a little easier as he goes a little farther out of his way to fly around the drone wall. If he shoots some drones, all the better; it just drains his batteries a little faster, encouraging him to stop wasting time.

*Playing a waiting game is always risky. While the drones might influence the Andromedan, they are also gone and a fairly easy target for this T-bomb spread over just 3 hexes.*

*Rated the best Tournament Term paper in this issue.*

### FLYING THE TOURNAMENT ANDROMEDAN

— *Commodore Ken Burnside, USS Wisconsin*

The Andromedan tournament ship has several inherent advantages on the tournament map, most of which can be maximized by following this approach.

1) Plot 27 hexes of movement, 26 of them powered by warp, the 27th by impulse. This will (on Turn #1) burn .33 batteries and give you 6.67 points of reserve warp available, enough for two HETs.

2) Your first pass against most opponents should be at range 3 and 1 hex off of his forward center-line. This will enable you to alpha strike at range 3 and damage your opponent's #1 shield. Moreover, most opponents lose some firepower at that particular position, in particular, the D7CT and the TKR, who lose their cross-deck wing phaser arcs. The alternative firing position is at range 3 on the hex spine between the #1 and #6 (or #2) shields. Either of these positions will enable you to get an angle of displacement that will force your opponent into an HET to chase you. A range 5 shot allows an opponent to turn and follow you without the HET.

3) Never engage in the middle of the map. Engage along one of the edges, and displace toward the middle of the map; then run. On your battle pass, beam your T-bomb (and dummy) out so that your opponent is all but forced to run over them if he aims for pursuit.

4) When you blow the displacement, just overrun. Your target will eventually have to HET to get your aft panels, at which point you can HET and bring your forward PA panels back in . . . and gain more distance.

### TOURNAMENT QUICK START

— *Captain Tony Zbaraschuk, USS Indiana*

On the first turn, it is a frequent practice to move at lower speeds during the first half of the turn, speeding up during the second half. If you are trying to move as far as possible, it may be better to go fast (speed 30 or 31) during the early part of the turn and then slow down during the second half. This will allow you to HET in the second half (when you are more likely to need to) and gives you some power to arm heavy weapons.

### HYDRAN TOURNAMENT TACTICS

— *Lieutenant (JG) James Webster, USS California*

Start the game at speed 16, and load only the two fusion beams on the side you will make your battle pass on. On Impulse #16, do a mid-turn speed change to 31 and charge your enemy, dropping your fighters at range 9 while continuing in to as close a range as you can get. Be willing to take some punishment from your opponent. At the end of the turn, you should be in the 3-5 hex-range bracket and should fire everything possible. During the following Energy Allocation Phase, plot multiple speed changes at every opportunity, starting from the highest speed you can afford. The two previously unfired fusion beams should be suicide overloaded and all remaining phasers charged. Close in to point-blank range and gut the target. Your fighters will now be able to close in and finish the target.

### THOLIAN COUNTER-TRACTOR TACTICS

— *Ensign Scott Fridenberg, USS Oklahoma*

The Tholian tournament ship can be especially vulnerable to being anchored. You can ill afford to be allocating power to the tractor beams "just in case", and trying to re-charge phasers and the web caster can leave you at a low enough speed that your opponent can reach tractor range. He will probably try for range 1 to prevent your using the web caster or the snare to break the tractor. Against the Gorn or Romulan, this usually means a quick and nasty death. Against a drone-armed race, however, you may be able to survive awhile.

If you feel you cannot break the tractor, consider letting him have it and tractoring him back. Survive the turn as best you can. On Impulse #29 try to place a snare in the hex he will occupy at the end of the turn. As you are probably both moving, this may not be possible.

During the tractor auction, bid as much negative tractor energy as you can afford to while maintaining your tractor. During the Initial Activity Phase, you write down your tractor rotation moving him 1 hex away from you. If he failed to rotate you 1 hex closer to him, you will be successful. If he did attempt to rotate you toward him, you will have avoided being pulled to range 0 where your options for dealing with seeking weapons are limited and your web caster and snare are useless. If you succeed in rotating him away from you, the effectiveness of your negative tractor energy is doubled. If you succeeded in placing the snare properly, the tractor is broken when the snare goes up on Impulse #1 and any seeking weapons he launches are trapped.

As an alternative, if he has used his HET bonus and he does not have the firepower to seriously hurt you that turn, you might let him keep the tractor, plot a speed of 24 or greater for the first several impulses, throw a web behind him of strength 12 or better, and shove him into it. Under (G7.3222) his chances of breakdown are increased by one. If he does breakdown, then the tractor is broken and he will take internal damage under (G7.3223). Do not try this if he has a good chance of destroying both tractors before you can shove him into the web.



## VICTORY AT GENCON 94

by Captain-General Bill Albert

I flew the Kzinti tournament cruiser in the Captain's tournament because the drones make it the most flexible ship in the event. They allow me to leave disruptors uncharged and still have more damage potential than most opponents.

Drone tactics are the heart and soul of a Kzinti. I launch drones late in the turn and use fast drones to restrict my opponent's movement. I launch the scatter-pack in the middle of the map on a turn where I am chasing my opponent into a corner. I want its drones to follow my ship, as I follow 1-2 waves from my racks. This is important. I never put 10 drones in one stack. One weasel gets them all. I space the drones to force my opponent to stay under the weasel restrictions without the ECM shift while my ship closes for the kill.

My favorite speed plot for Turn #1 is speed 16, jumping to speed 31 on Impulse #28. Moving last on each impulse at the end of Turn #1 is a huge advantage and is much more important than making a turn mode bracket or being able to HET. "Maneuver is the queen of battle."

I entered the Patrol tournament (in addition to Captain-General) because I wanted to get a few games under my belt before the main event. I picked the Hydran tournament cruiser because I have seen too many SFB players lose games because fear of a few internals or shield hits caused them to turn off at a critical moment. You cannot win with a Hydran and not take damage. I finished with a 3-0 record in the Patrol.

### Patrol #1 (Hydran): 3 turns *Squashing the Bug*

**Opponent: Jeremy Williams (Rated Ace), Seltorian**

Jeremy is a fine player (he lost to Paul Scott in Captains round #4 and won seven times in the Saturday Patrol) but this match-up definitely favored me. My strategy was to chase him into a corner on Turn #2 so that I could overrun him on Turn #3.

We danced around in the center of the map on Turns #1 and #2, exchanging alpha strikes at 6-8 hexes range. I dropped his #3 shield to one box on Turn #1 while he rolled poorly and only put 9 damage points on my #3 shield early on Turn #2. We both HETed, and I spent the rest of Turn #2 chasing him into the top right corner of the map.

On Turn #3, I had him cornered at range 5. He TACed while I charged and launched fighters. He hit me for 22 internals, crippled one of my fighters, and did 5 points of damage to the other one before he ran out of weapons. He resigned as I launched two suicide shuttles to be followed by an overrun with two phaser-Gs, three fusions, and the uncrippled Stinger.

### Patrol #2 (Hydran): 4 turns *Frying the Fish*

**Opponent: Scott Natrass, WYN Great Black Shark**  
**Options: Two drone racks (LS/RS)**

I respect any ship with four drone racks. My plan was to move slow, reinforce my shields, and exploit my hellbores. On Turn #1, Scott bounced disruptors off my reinforcement and turned off. I closed to range 4 and dropped his #3 shield to one box while he removed half of my #6 shield.

On Turn #2, I TACed with 12 points of reinforcement on my #6 shield and weaseled two turns of drones as he split fire on my #5 and #6 shields. I launched the Stingers, and they scored 4 internals through his #3 shield while Scott fired phaser-3s,

scoring 9 points of damage on one Stinger, and 5 points of damage on the other. I ended the turn hacking off half of his #4 shield with my phaser-1s.

On Turn #3, my uncrippled Stinger slashed him on Impulse #1 for 12 internals as he fired phasers, killing both fighters. We spent the whole turn inside range 8, and I scored volleys of 15, 18, and 19 points of damage at ranges of 2 to 4 hexes at the end of the turn. I blew him up on Impulse #2 of Turn #4 with overloaded fusions and one of my phaser-Gs.

### Captains #1: 3 turns

*Those Who Are About to Die . . .*

**Opponent: Paul Pomykala, WYN**

**Options: Two plasma-F-FP, two disruptors (LS/RS)**

With two wins under my belt, I felt ready for my first Captain's match. Paul's ship kills people by overwhelming them with seeking weapons or by Mizia attacks through their #1 shield as they chase him. My plan was to fly slow with weasels and overloaded disruptors ready. On Turn #1, I scratched each of his forward shields while he removed half of my #5 shield.

On Turn #2, Paul charged at speed 30, following both plasma-F torps, while I plotted 8/4/14 with overloads. I put 11 internals through his #3 shield at range 4 and only lost half of my #1 shield in return. I weaseled his plasmas (one pseudo), moved to the center of the map, and launched drones (including one type-IV).

On Turn #3, I plotted speed 14, charged disruptors (two overloaded), and put 3 points of power into tractor. I kicked out the scatter-pack and continued the chase. He used his drones to kill mine as I launched four fast drones (one type-IV). I tried to Mizia him through his down #3 shield the next five impulses at ranges of 6 to 8 hexes, but only scored two volleys of six and 2 damage points. Paul used all his phasers and both tractors to deal with my drones. He launched a plasma-F torpedo to scare me away so that he could escape across the bottom of the map, but I charged through it. He resigned when I won the tractor auction.

### Patrol #3 (Hydran): 6 turns *Stinging the Cluster*

**Opponent: Kerry Mullan (Rated Ace), WYN**  
**Options: PI-F-FP, ph-G-FA, ph-G-LS, drone RS**

Kerry is a very strong player; he lost to an Andromedan in the Patrol finals, but beat two Andros on his way. He likes to follow his drones and plasmas to a range of 0-2 hexes where he can plaster you with 4 phaser-1s and 11 phaser-3s, followed by 5 more drones. My strategy was to keep all fusions charged, fire one overloaded hellbore per turn, keep two wild weasels ready, and wait until he ran out of drones.

Turns #1-5 went pretty much according to plan. I fired one overloaded hellbore per turn, missing on Turns #2-4 while Kerry was firing phasers and launching drones. I outran a pseudo torpedo on Turn #2 and weaseled a real plasma and drones on Turns #3 and #4. On Turn #3, Kerry got a range-2 shot (only one phaser-G) for nine internals through my #3 shield. On Turn #4, I launched both fighters to prevent an encore. The fighters landed to rearm after killing his Turn #4 drones.

Turn #6 was decisive. I TACed while he charged at speed 17, and we launched admin shuttles at each other. I killed his last three drones and an admin shuttle with my right side phasers. On Impulse #12, I hit him with phaser-1s and an overloaded hellbore, scoring internals. He launched a plasma-F torpedo which I weaseled. After the explosion we were nose-to-nose in the same hex. His phasers did 33 internals to my ship



while my three fusions (two overloaded) and phaser-G did 32 to his ship. Next impulse I grabbed him with 7 points of tractor energy and launched both Stingers. The Stingers blew him up on Impulse #29 when they fired through a down shield at range 0.

**Captains #2: 6 turns**

***Sleepwalking through the Cluster***

**Opponent: Gary Langtimm, WYN**

**Hellbore FA, photon FA, disruptor LS, ADD-12 RS**

This was my first round Friday morning, and I played it like a complete idiot. If there were any justice, Gary would have won this game. On Turns #1-2, I ran to the right side of the board and scraped his shields while Gary reached range 4 midway through Turn #2 and did 4 internals through my #5 shield.

Turns #3-5 were a nightmare. He killed 18 drones, got 11 internals when I let him have a range 2 shot through my #5 shield after mixing up right and left, crippled my #3 shield with his Turn #4 fire, and got 9 internals with his Turn #4 hellbore. I did not do any internals to him until Impulse #29 of Turn #5 when I cornered him for 15 to 20 internals at range 1 through a wild weasel ECM shift.

We started Turn #6 at range 1, so I plotted TAC/-4 (on 8) to try escape to range 3. I cut drone tracking on Impulse #4 to keep him under the weasel, but he fired anyway. His photon missed, so his direct fire only did 2 internals, but the hellbore put 20 internals through my two down shields. Miraculously, he only hit two phasers and a disruptor. He weaseled again, and I blew it up with phasers. On Impulse #10, he announced a plotted speed change to 3 and failed to tractor me at range 2. Next impulse he moved to range 1 and we both launched drones. He resigned when I killed his drones since he had no way to stop the 60 points of damage I launched at him.

**Captains #3: 8 turns**

***Fortress Kzinti***

**Opponent: Brett O'Neal (Rated Ace)**

**Orion: 2 HB, PI-F, 2 Drone LS/RS**

This was a long drawn out affair. I ran to the corner on Turn #1, and Brett followed. On Turns #2 and #4, Brett charged and we exchanged overloads at range 5-8 while I TACed. On Turns #3 and #5, I chased him with standard disruptors. I phasered plasmas and ate them on Turns #2 and #4. We launched admins as phaser platforms on Turn #5.

On Turns #6-8, I TACed, firing four overloads each turn. I think I had him trapped in a corner, and we never left range 8. I used my last three drones on Turn #7, two of which were downloaded from my scatter-pack. Brett resigned during Energy Allocation of Turn #9. He only had 15 power left while my ship had lots of shield damage but no internals.

I remember discussing the game afterwards with Brett, and we agreed that neither of us had made a mistake, nor did we see anything which could have been done differently. Having qualified for the final 16, I stopped playing for the day.

**Captains #4: 7 turns**

***Using all the shields***

**Opponent: Allen Phelps (3x Rated Ace), Gorn**

When I first started playing the Kzinti, I discussed tactics with Mike Calhoun, a rated Kzinti ace from San Jose. Mike told me that any Gorn who enveloped was cat food, as long as the cat had the courage to run through all of the plasma. Thanks Mike!

On Turn #1, Allen charged at speed 16/31 while I used my old standby, moving wide right and turning in to get running room. Three disruptors hit his #2 shield when we reached range 15. On Impulse #32, he launched an RP enveloped plasma-S torpedo. Next turn I ran for the bottom left corner, fired phasers at the plasma, and ate it for 17 points. Allen used all of his phasers and one tractor to deal with two turns of drones and popped the LP plasma-S torpedo as another enveloper on Impulse #32 as I hit him with right side disruptors. I weaseled his torpedo before accelerating to begin the chase. Allen circled away at moderate speed, killing my last drone, as I scored a couple points of disruptor damage.

Turns #4-5 were decisive. I ate a full strength enveloped plasma-S torpedo and a phasered down plasma-F torpedo each turn in order to chase him into the top right corner. I timed my launches perfectly, holding the Turn #5 drones until after he had used phasers to kill my Turn #4 drones. On Turn #5, Impulse #21, he hit the wall in the top right corner so that he could weasel. We ended the turn at range 3 with my four scatter-pack drones at range 4. I fired disruptors (two overloaded) and phasers to take down his #2 shield. Allen fired at my drones, killing none.

On Turn #6, Allen killed two drones and tractored the other two. He weaseled on Impulse #12 while I closed to range 1 on Impulse #16. When the weasel's explosion period ended, I put 30 internals through his #1 shield. Next impulse I TACed my right rear phasers into arc for 8 more internals, killing his last tractor. Turn #7 was anticlimactic, Allen launched a fast loaded plasma-F torpedo, which I ignored. He resigned when my fire did 70 damage points to his #6 shield. I ended the game with six boxes left on shield #1; two boxes left on shields #4 and #5; and one box each on shields #2, #3, and #6.

**Captains #5: 6 turns**

***A Lesson Learned***

**Opponent: Ken Rotar (2x Rated Ace)**

**WYN: 2 HB, Disr LS, Ph-G RS**

This WYN is dangerous. I lost to a similar WYN flown by Alex Pundy in last year's final round, so I know what this ship can do. On Turn #1, I held a wild weasel and ran to the bottom right corner as Ken charged at speed 30. I hit his #1 shield with two disruptors and launched drones.

We exchanged fire early on Turn #2 at range 4. Ken reduced my #6 shield to three boxes, while I did 2 internals through his #6 shield. Ken launched drones at my drones and ran away with me in distant pursuit.

On Turn #3, Ken moved speed 21 while I chased him into the top left corner at speed 28. I launched the scatter-pack on Impulse #16 and drones on Impulse #32. Ken launched drones on Impulse #31 at my drones. We started Turn #4 at range 6, so I plotted 16/8/4/0 (trapping him) with 4 overloads, 3 points of power in tractors, and 6 points of reinforcement on my #6 shield. When Ken announced speed 0, I turned off and we ended the turn at range 9. He weaseled my drones and stayed under the restriction until he had cleared my SP. I launched more drones on Impulse #32.

On Turn #5, I plotted 8/4/0 (16/24) with 4 overloads and 11 points of reinforcement on my #6 shield. Ken moved speed 4. He killed my drones with his phasers as we closed. On Impulse #32, we were at range 4 with my #2 shield facing his #1 shield. I launched drones and we exchanged fire. I only scored 25 points of damage when three of my four disruptors missed. Ken's direct-fire equalized shields #2 and #6, so his hellbores did no internals.

On Turn #6, we both moved speed 8. Ken used five phaser-3s to kill my Turn #5 drones. He launched drones on



Impulse #12 at range 2 which I killed with four phaser-3s and an admin shuttle. When we reached range 1, I scored 25 internals as he fired his last phaser-3s for 8 points of damage on my nose. I launched four drones, and he resigned when his "ph-1 at each" strategy did not kill the type-IV.

### Captains #6: 2 turns

#### *Vengeance Is Mine*

**Opponent: Paul Pundy (5x Rated Ace), WYN**

**Options: Two hellbore FA, ph-G LS, disruptor RS**

I lost to Paul's brother Alex in last year's final round, so this was my chance for revenge. I saw Paul talking with Ken Rotar about how I had fought round 5, so I knew I needed to do something different. I was feeling aggressive, so I decided to head to the near corner and then circle back to take Paul off my #2 shield on Turn #1.

I used my 16/31 plot, overloaded the right side disruptors (left side disruptors were standard loads), and put 4 points of reinforcement on my #2 shield. Paul moved 21/30 (on 22) and slipped toward me. Midway through the turn, Paul turned in and started slipping toward my side of the map. I turned back into him on Impulse #26 just before my speed increase.

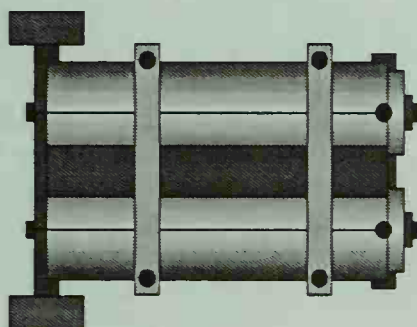

On Impulse #28, we reached the decisive position. We were facing each other at range 5, 1 hex away from the hex row off our #2 shields. Since I got to move last, Paul had to decide what to do. If he fired now and turned away, I would get a range-4 shot at his #3 shield. Paul held fire and turned in as I slipped away to stay at range 4. I launched one drone as we exchanged fire. He missed with his disruptor and only got 10 points of damage with phasers on my #2 shield, so his overloaded hellbore was spread across four shields. Meanwhile, I did 6 internals (getting a drone rack, phaser, and a left warp) through his #1 shield. I launched three more drones on Impulse #30 while he launched one drone on Impulse #30 and two drones on Impulse #32. He killed all four of my drones with his phaser-G and remaining phaser-3 on Impulse #31 while I killed his with my right side phaser-3s on Impulse #32. We ended the turn at range 2.

On Turn #2, I plotted speed 8/4/0 (on 5/13) with a HET, overloaded all the disruptors, and recharged my phasers and batteries. Paul tried to run away at speed 30. On Impulse #4, I HETed towards the bottom of the map. Paul turned left, and I fired four left side phaser-3s into his #4 shield for 5 damage points. Next impulse he slipped out of my FA arc, and we exchanged fire. He scratched my #6 shield while I hit his #4 shield for 1 internal. Paul resigned on Impulse #8 after I turned my FA/R weapons to bear and fired for another 15 internals.

I got to watch the last several turns of the other semifinal match, Paul Scott (Romulan) versus Alex Pundy (WYN). It lasted 14 turns. Paul was badly crippled (67 internals) with two down shields, and Alex had more than 40 internals with four down and two weak shields for the last six or seven turns. Paul stayed at speed 4, weaseled for the ECM shift, and launched one torpedo per turn. Alex circled, firing his remaining hellbore at 8-15 hexes range every other turn. Paul won the game as his torpedoes whittled away Alex's ship while Alex missed with his last three hellbore shots.

### Captains #7: 7 turns

#### *Famous Last Words*

**Opponent: Paul Scott (3x Rated Ace), Romulan**

The Romulan tournament cruiser is probably the hardest opponent for the Kzinti. Normal drone tactics do not work against a cloaked ship. I had only fought this match-up once before (I lost), so I was not sure how to play it. I finally decided to play like a Klingon.

On Turn #1, I used my favorite plot, charged disruptors, put 5 points of power in tractors, started three wild weasels and slipped to the right to get some maneuvering room. Paul charged at speed 24, fire control off, launched an enveloped plasma-S torpedo on Impulse #18, and turned to the top right hand corner. I scraped 9 points off his #3 shield and phasered down the torpedo, eating it on Impulse #29 for 30 damage points. The turn ended at range 7 as Paul launched a plasma-F torpedo and I launched drones.

On Turn #2, I plotted 8/4/14 with 4 overloads and 3 points of reinforcement on my nose while Paul moved 0/-2 (on 16) with fire control off. Paul weaseled on Impulse #1 for the shift while I fired phasers at his torpedo and ate it for 12 damage points (minus 7) on my #1 shield. My drones hit his wild weasel on Impulse #15. Paul launched another enveloped plasma-S torpedo and weaseled after I announced emergency deceleration on Impulse #16. I fired disruptors for 6 damage points on his #6 shield and launched my own wild weasel on Impulse #19. On Impulse #25, I fired phasers killing his WW.

On Turn #3, I plotted 0/10 (on 4) with normal disruptors, and 7 points of reinforcement on my #1 shield. Paul launched a plasma-F torpedo on Impulse #1 and cloaked. I fired disruptors for 12 damage points the same impulse, reduced the plasma warhead by 10 points and took it on my #1 shield for no damage. Paul announced speed 9 on Impulse #8, and we started circling. On Impulse #32, he started uncloaking so I launched four drones.

On Turn #4, I plotted 9/4 (on 5) with overloads and 8 points of reinforcement on my #1 shield. Paul uncloaked, launched a plasma-F torpedo on Impulse #4, weaseled on Impulse #7, and jumped to speed 3 in reverse on Impulse #11. He launched an enveloped plasma-S torpedo on Impulse #15, which I weaseled, and started cloaking on Impulse #16. On Impulse #18, his torpedo hit so I fired disruptors on passive at range 4 for 24 damage points to his #2 shield.

He stayed cloaked during Turns #5-6 as he moved in reverse and I tried to stay close. I took 14 points off his nose on Turn #5 with disruptors at range 1. I HETed to get the same shield on Turn #6 but only got 6 (reduced to 5) points, leaving him a one box nose shield. I did not fire phasers either turn.

Turn #7 was decisive. We started the turn at range 1 with my 25-box #6 shield facing his 24-box #5 shield. I overloaded, plotted 0/4 (on 8 with one TAC), put 7 points of power in tractors, and held 1 wild weasel. Paul started uncloaking on Impulse #1, but for some reason I kept thinking he came up on Impulse #2. I lost a tractor auction at 12 points of power on Impulse #5, so I launched a type-IVF to knock down a shield. Paul TACed, and the drone reduced his #6 shield to one box as he emerged from cloak. Paul tractored me and withheld launch after long thought, correctly deciding that if I took his RP plasma-F torpedo on a fresh shield he would lose the exchange. I goofed and launched a type-IF drone. Paul killed my drone with two phaser-3s and fired a phaser-1 for 4 damage points on my #6 shield. As he waited for me to roll my fire, he said, "You will not get deep enough to kill my tractor." Paul resigned when I rolled 74 internals, killing the second tractor with internal 71. ★★★



# ASK UNCLE ARDAK

*Dear Uncle Ardak: My D5 has been assigned to check out several star systems for Jindarians. What do I do if I find one?—Kommander Friden Kerg (no relation to that other one)*

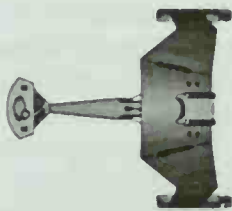

My Dear Friden: When you find a Jindarian, or anything else while you are assigned to that sort of patrol, the very FIRST thing you should do is PHONE HOME. Let the sector admiral know what you have found and what you plan to do. If things go horribly wrong, at least he'll know where to look for the wreckage. While waiting for reinforcements, your mission is to disrupt the Jindarian activities while keeping your own ship intact. Jindarians rarely appear alone and are very dangerous opponents. Your best strategy is to stay at high speed and moderate range, keep some ECM up and reserve power full, and snipe at his prospecting shuttles with phasers and disruptors. Avoid traveling through areas that may hide other Jindarians. Eventually, he'll either have to recall his prospectors or run out of them, and either way he's shut down.

If you do have to actually fight a small Jindarian asteroid ship, you're only going to get one pass. As always, use your drones (and a scatter-pack) to make one grand attack. The drones will force his rail guns onto the defensive, allowing you to exchange disruptor shots for phasers. A long-range duel can buy time. At ranges over 260,000kms, you actually outgun him, but of course his shields are thicker.

Remember that you will always have the initiative against a Jindarian ship because he cannot catch you! Unless, of course, you surrender the initiative by letting yourself get surprised, so stay clear of big asteroids!

Of course, if a destroyer or frigate wants to fight, you will have little to fear and can concentrate on not letting him lure you into areas where the big asteroid ships could hide.

*Dear Uncle Ardak: I'm doing a historical thesis here at the DSF Academy on the medium-speed era (Y168-180) and need some advice. My analysis has shown that in an equal battle between a carrier and non-carrier squadron, the non-carrier squadron has more heavy weapons and can snipe the carrier squadron to death from long range. With an entire squadron firing, even cruiser-sized escorts can be badly shot up. How was this avoided during the period?—Cadet Kaus*

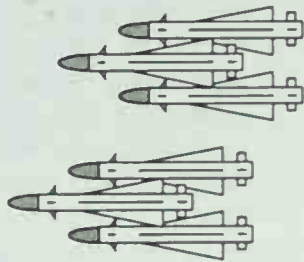

Dear Cadet: Ah, history, one of my favorite subjects when I was a cadet. Of course, that was before I started writing my own history, as every good Klingon must.

Any carrier fleet which allows this to happen has made the most basic mistake of all: playing the enemy's game.

The best carrier commanders make the "warship" commanders play carrier rules. One method was to put the fighters about 10 hexes from the ships along the primary threat axis. He either has to come through your fighters or stand off out of their range where he can't hit your fleet. Lend the fighters max ECM, which with EM or Small Target Modifiers should make them survivable until they can reach drone launch range.

If he somehow forces you to play his game, give yourself every edge. Use EW and EM to avoid being a worthwhile target, and do *something* with your fighters and other weapons to ensure that he takes as much damage as you do, preferably more. He will have to come to you to get a specific unit, and you can make him pay a heavy price.

*Dear Uncle Ardak: In the training simulators, I've been assigned to fly a Neo-Tholian ship, which is bad enough, but now I have to fight a Gorn. Worse, he won't use his torpedoes correctly; he just stands back and bolts them. What do I do?—Lt Kommander Kime*

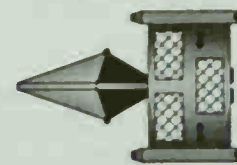

Dear Lt Kommander: If he's getting you this upset, it doesn't sound like he's using his weapons incorrectly. What has you upset is that you planned for a Gorn who played a seeking game and drew one who was using a more "direct" approach. Let him bolt at medium range; the torpedoes are not as strong and the chances of a hit are small. The statistics on a long-range duel are all on your side. When you are ready to attack, use your cast web to block him so that you can get close. Time it to solidify just before his torpedoes are armed so that he will have to use quick-loaded plasma-Fs. That will burn his reserve power, by the way. Remember to take any of those long-range shots on your flank shields and protect that #1 shield!

*Dear Uncle Ardak: I am commanding a battle station on the Federation border. In the proverbial confused fighting, I find myself confronted with a powerful Federation force while protected by only one cruiser. My PF flotilla is off on a mission. What should I do?—Station Kommander Kmin*

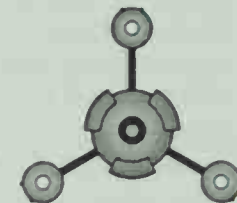

Dear Station Kommander: The objective is to hold out until a reinforcing squadron can reach you. The Feds are unlikely to make a close-range attack, even if they do outgun you by 30%, because of your phaser-IVs. So that means winning two battles: his drone bombardment and the long-range duel. Between your own weapons and those of the cruiser, the long-range duel is going to be fairly close, and you can even that up by using electronic warfare and even ECM drones.

Stopping his drone swarm is going to be difficult, assuming he doesn't bunch his drones where a single T-bomb can get them. Use your short-range phasers (and those of the cruiser), tractor beams, and T-bombs. Launch fighters as scatter-packs so that they can salvo their entire drone load at once in a counter barrage. Once they fire, beam a pilot on board or just tractor them back into the hangar. Use your aegis system to identify drones and your special sensors to kill drones and provide more jamming.

Our Romulan allies, without access to ECM drones, would have the advantage of using shot-gunned plasma torpedoes to help stop the drones. The Lyrans, of course, have ESGs.

*Dear Uncle Ardak: I have been given my choice of Klingon carriers. Which carrier should I take?—Kommander Kansickle*

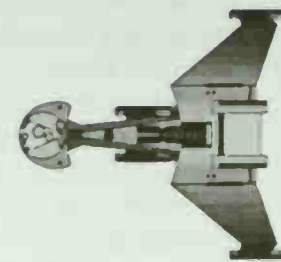

Dear Kommander: The B10V, of course. Was there more to the question than that?

Really, was this a trick question?

*Dear Uncle Ardak: I am doing a historical research project on the Early Years era. How should I treat the Tholian PCs of Y90?—Kommander Kochrel*

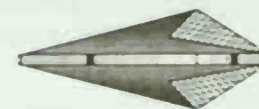

Dear Kommander: As the X-ships of their day. Nothing else explains their operations. If they had had the logistics to support a major offensive, they could have given the Empire some anxious moments.

★★★



## STAR FLEET UNIVERSE INDEX

This index is designed to assist players in locating obscure references to SFB history. It can also be used by fiction and scenario authors in preparing new material. It is compiled from all SFB fiction, scenarios, and other historical material. Ship names were published in Module MO#2.

## INDEX OF SFB FICTION STORIES

- A Sense of Obligation: Captain's Log #16; Federation CA *Ramilles* enters Tholian space on an unauthorized mission to rescue prisoners held by the Tholians; SL148.
- And to the *Republic*: Captain's Log #5; In Y173 the old Federation CA *Republic* defeats two groups of Romulan raiders only hours before the Romulan entry into the General War; SL88.
- Battle of Olsen's Reach: Captain's Log #8; Orion CR *Doomsday Exchequer* discovers a log buoy from the Federation CA *Hornet*. The log tells of the *Hornet's* final mission, to guard the Federation High Commissioner at a ceasefire talk with the Klingons and Romulans in Y174. The talks ended in disaster and extended the General War, instead of ending it; SL111.
- Behind the Glory of the Heroes: Nexus #5; Inside view of a Federation battlestation under Romulan attack in Y161; first of only three SFB fiction stories without a scenario. This story was repeated in Captain's Log #13.
- Betrayal: Captain's Log #14; Klingon squadron attacks Federation BCF *Forrest* to prevent the Romulans from negotiating a separate peace in Y182.
- Brotherhood Banquet: Nexus #13; Not really a story, but an Academy article involving Klingons, Lyrans, and Romulans discussing tactics.
- Brothers: Nexus #17; Battle between a Lyran CL and a Hydran Lancer in Y171; SH40.
- Cold Front: Captain's Log #11; Two-part story describing how the Lyrans decided to attack KzIntis first in the General War; SL132.
- Day of the Eagle: Captain's Log #5; Ten years after the Romulans invaded, a Federation historian interviews the admiral who commanded the Sixth Fleet about his deployments and plans for that day. Story is used to connect three other stories: *And to the Republic*, *Encounter at Denebola*, *Surprise Reversed*; has no specific scenario of its own.
- Duel Escape: Short fiction story in Module T (Tournament Book). Federation and Gorn starships find themselves teleported from the real universe onto a game map.
- Encounter at Denebola: Captain's Log #5; A Federation squadron is sent to Denebola to negotiate a treaty with an Orion Pirate in Y173, but discovers that the Orions have already made a deal with the Romulans; SL89.
- Escape From The Holdfast: Captain's Log #8; Klingon ships attempt to slip into the Tholian Holdfast and capture a Tholian ship, thereby (perhaps) gaining the secret of web technology in Y149. They capture the ship, but are unable to get out of Tholian territory with it and ultimately had to abandon the captured ship. Scenarios SL108A, SL109, and SL110 portray the major actions.
- First and Future Shock: Nexus #16; ISC strike cruiser *Celestra* intercepts and defeats the Romulan Sparrowhawk cruiser *White Hawk* near the planet Dastaal in Y180; SH44.
- First Command: Nexus #11; Federation Lt Commander Scofield is given command of the broken down CL *Connecticut* and ordered to take her to a shipyard for overhaul in Y176.
- Unknown to him, he is being used as bait to attract a marauding Klingon frigate squadron; SN13, SN14.
- First Round, The: Captain's Log #3; The "Masters" kidnap Orion Pirate Deth O'Kay for their wargames in Y181; SL50.
- Frontier Patrol: Nexus #9; Klingon F5 *Nova* intercepts a Kzinti Q-ship in the neutral zone in Y180; SN11.
- Ghostlight: Day One: Captain's Log #9; A first-hand account of the first day of the Klingon assault on the Federation in Y172; told by Lt. Matt Oberu, an F-8 pilot stationed on BATS 7. The base, and all of the defending ships, were destroyed; SL117.
- Graduation Exercise: Prime Directive adventure.
- Gray Rations: A short scene of an abortive mutiny on a Klingon ship, published in the Prime Directive section of Captain's Log #12.
- Hold Until Relieved: Captain's Log #10; Federation frigate *Chadwick* arrives at a BATS abandoned behind Romulan lines earlier in the war in Y179.
- Klingon Battlecruisers: Nexus #2; A brief "historical" article on some Klingon D7s with unusual modifications; revised and reprinted in Captain's Log #13.
- Long Road Home: Captain's Log #12; A spy story of a WYN ship moving through Klingon and Lyran space in Y182.
- Meeting of Giants, A: Captain's Log #6; A Klingon force led by B10 *Invincible* links up with Federation SCS *Napoleon* to defeat two Dominators in Y195; SL98.
- Objective Juggernaut: Captain's Log #1; An extra-galactic death machine invades the galaxy in the neutral zone between Klingon and Tholian space in Y168. Intercepted and defeated by four ships: Federation CC *Excalibur* under Richard Grey, Klingon D7C *Darkslayer* under Korath, Tholian cruiser *Arrakk* under Sectin, Orion CR *Gossamer Phoenix* under Felna Graymane; SL1.
- Patrol: Nexus #8; Federation fighters from an auxiliary carrier become the first to meet Klingon PFs in Y179; SN8, SN9.
- Refiner's Fire: Captain's Log #2; Romulans try to ambush Gorn cruiser *Reptilicon* in order to tilt the balance of power sufficiently for a pre-emptive attack to be possible in Y167. Two KRs and a Klingon D7 attack, but the *Reptilicon* discovers the ambush due to a Klingon error and flees toward the Federation border where it encounters the CC *Lexington*. The *Reptilicon* enters the Federation and is pursued by the Romulans, forcing the *Lexington* to side with the Gorn ship. The Klingon ship and one of the KRs is destroyed; SL25.
- Report by Tiercellus: Nexus #10; A Romulan squadron provokes a battle with two Federation NCLs, destroying both for the loss of two SkyHawks in Y174; SN12.
- Rescue on Roon: Prime Directive adventure found in Module T and to be republished in expanded form later.
- Sending Gerard Home: Nexus #14; Various Orion officers instruct Ensign Gerard in the skills needed to operate an Orion ship while he is awaiting transport home after being captured.
- Surprise Reversed, The: Captain's Log #5; In Y173 Commodore Stocker of the *Lexington* detects a Romulan invasion and launches a pre-emptive attack that destroys three Romulan ships, then falls prey to a Romulan trap; SL90/SH2.
- Tactical Point, A: Tactics Manual; The Klingon cruiser *Antagonist* under command of Captain Kagan attacks the Federation CC *Kongo* under Phil Kosnett in the neutral zone in an inconclusive duel. There was no accompanying scenario.
- Too Close to the Flame: Captain's Log #15; In Y181 a Kzinti frigate squadron engages a Lyran CC on a raiding mission. One frigate is destroyed, and the Lyran CC is forced to withdraw; SL144.



- Two Views of the Federation: Captain's Log #11; Humorous story comparing how the Feds see themselves and how the Klingons see them.
- Two Views of the Klingons: Captain's Log #10; Humorous story of a Klingon ship en route to raid a Federation colony, showing the action as the Klingons would like to think they do it and as the Federation believes the Klingons do it.
- Uprising: Prime Directive adventure.
- Volunteers: Captain's Log #16; A short story about the crew of a Hydran frigate *Goodwind* in the Magellanic Cloud on the Warlord Tri-Video series.
- Warrior's Death, A: Nexus #12; Klingon FX frigate *Vandal* in Y205 passes through a time warp into Y175, the middle of the General War. It destroys a Federation NCL but is itself destroyed by the Klingons who do not recognize it; SN15-16.
- What Price Victory?: Captain's Log #7; In Y165 the Federation CA *Yorktown*, en route to rescue a mining colony from a radiation leak, is stopped by the Klingon D7 *Pitiless* in an asteroid belt; SL104. Story emphasizes two female commanders.
- Where Wisdom Fails: Captain's Log #4; In Y156 the Hydrans destroy Klingon Battlestation #13 with the first combat test of the hellbore. The D7 *Defiler* chases the retreating Dragoon in company with the frigate *Fury*. Story is unusual in that it is only from the Klingon point of view, rather than from both sides; UL2, SL79, SL80, SL81.
- Within the Glove: Module F1; One-page fiction story about Jindarians. Story revolves around a plot in which junior relatives of the Jinbaro try to overthrow him.

## INDEX OF CHARACTERS IN SFB FICTION AND HISTORY

### A

- A'dva: Kzinti Captain 5, formerly captain of FH206 but transferred to command SF131 *Cat's Eye* to allow Grrrv'en to command FH206, *Too Close to the Flame*; SL144, Y181.
- A'zhor-kaln: ISC, Qnaabian, communications officer on *Celestra*, *First and Future Shock*; SH44, Y181.
- Aarie: Fed; Lieutenant, Science Officer, *Excalibur*, Deian; *Objective Juggernaut*; SL1, Y168.
- Abdul, Honest: Pirate trader, captain of CVL *Inside Trader*, tried to sell stolen fighters to Mad Jack Y175; SH37.
- Abudonni, Nhera: Romulan Centurion, member of Marcus Tal's Praetorian team on Debrock, Y172.
- Adrokos: Klingon, commander of F5 *Nova*, *Frontier Patrol*; Y180.
- Agrontio, Hector: Romulan Centurion, member of Marcus Tal's Praetorian team on Debrock, Y172.
- Akir, Victor: A warlord, ex-Star Fleet officer, CL#11.
- Akorri'Rhan: Cygnan shuttle pilot attached to Mizari'Jhot. Pursued by Romulans. Y164.
- Akros: Klingon, weapons officer on F5 *Nova*, *Frontier Patrol*; SN11, Y180.
- Alexander: Federation member of the *Excalibur Templars*, a Prime Team led by Chandler.
- Allenby: Federation, Human. Crew chief for MRS from *Battlestation #7* on Klingon border, *Ghostlight: Day One*; SN117, Y171.
- Andros: Federation freighter captain, claimed to be on secret naval mission; SG34.
- Ankrogeomonas: King of the Ankrogeans; SL87.
- Antilli: Federation, Andorian, *First Command*; SN13-14, Y176.
- Artemis: Romulan Sub-Admiral; third member of *Triumvirate* in Y167, mentioned as one of those approving the ambush of *Reptilicon*; *Refiner's Fire*.

- Assi: Kzinti crewman transferred from FH206 back to FF183, *Too Close to the Flame*; SL144, Y181.
- Astor: Jindarian who plotted against Jinbaro Shana, *Within the Glove*.
- Axel: Orion, Daven Cartel operations officer in Lyran sector in Y182. *The Long Road Home*.
- Azundar'kar: Cygnan tech officer, member of *Black Eagles Prime Team*.

### B

- B'Latt: ISC, Pronhoulite, first officer on *Celestra*, *First and Future Shock*; SH44, Y181.
- B'rok: Kzinti Captain 5, Commander of FF183 *Bold Claw*, killed in action, *Too Close to the Flame*; SL144, Y181.
- Babcock, Gailen: Federation Major-General, Commandant of *Prime Central*, Y164.
- Bahri'Joht: Daughter of Mizari'Joht, Cygnan pursued by Romulans, Y164.
- Bansett, Adrianna: Alpha-Centauran Sgt Major, member of *Black Eagles Prime Team*.
- Baranov: Federation, Human. Federation Council Vice Chairman at time of the *Battle of Olsen's Reach*; SL111, Y174.
- Becker: Federation marine sergeant, *Behind the Glory of the Heroes*.
- Bedalia: Girlfriend of Deth O'Kay in Y181, *The First Round*; SL50.
- Bek'Ahm, T'Laura: WYN, Ethnic Orion. Chief Engineer on WYN OLR *Shadowfox*.
- Benjamin: Federation doctor, medical officer on *Lexington* in Y173, *Surprise Reversed*; SL90/SH2.
- Bennett: Federation, commander, science officer on *Prince of Wales* in Y173 SL89, temporarily captured with *Goldsborough*, *Encounter at Denebola*. Could be same person as the officer of the same name in *A Warrior's Death*, Y175 SN15.
- Bennett: Federation, First officer and Science officer on *North Carolina*, *A Warrior's Death*; KIA SN15, Y175.
- Birash: Klingon, Communications officer, KIA, *Vandal*, *A Warrior's Death* SN15, SN16, Y175.
- Bl'nt: President's Liaison on Debrock, and secretly a member of the AARPF.
- Blackfoot, Samuel: Free Trader, discovered *Blackfoot Pass*; SL20.
- Blackwell: Orion agent, *The First Round*; Y181.
- Blankenship, Earl: Federation Communications officer of CA *Ramilles* in Y166, *A Sense of Obligation*.
- Bluebird Six: Call sign of F-18 fighter pilot, *Patrol Y179*. Also *Bluebird One* (squadron commander), *Three*, etc.
- Bna-Crit'sa: Federation, Arcturian, *Behind the Glory of the Heroes*. Y161.
- Bodo: A Dunkar services clerk on an unspecified Klingon warship, *Gray Rations*.
- Bolmark: Lyran Lt Cmdr in Y182, attended *Brotherhood Banquet*.
- Bombadier: Gorn Captain in *The First Round*; SL50, Y181.
- Bordrake, Tar: Klingon; Commanded Penal ship *Purgatory*, Kumerian's brother-in-law; SH11, Y182.
- Borkas: Klingon, scanner officer on F5 *Nova*, *Frontier Patrol*; SN11, Y180.
- Bowen, Alex: Federation Ensign (LT?), weapons officer on CA *Ramilles* in Y166, *A Sense of Obligation*.
- Bretanno, Philip: Federation human who accompanies Dr *Pasternak* to *Sentria*.
- Brezgonne: Tholian Commodore, commanded reinforcements responding to Klingon attack; SH6, Y167. Commanded Tholian contingent in *Operation Cavalry*; SH11, Y182.
- Brigadier: A military rank. The WYN military attache to the LDR, an ethnic Lyran, was addressed by this title in lieu of a name. *The Long Road Home*.



Brita: Jindavo under Shana, *Within the Glove*.  
 Brookes, Marsha: Federation ensign, on *Masterson*, *And to the Republic*; SL88, Y173.  
 Brr'ev: Kzinti Lt 1st, leader of a Cabal team, assigned to FH206 in Y181, *Too Close to the Flame*; SL144, Y181.  
 Brubaker, Brian: Federation, captain of NCL *North Carolina*, *A Warrior's Death*; KIA, SN15, Y175.  
 Brzk'Girn: Seltorian commander that pursued the 312th Battle Squadron to the Milky Way R15.1A, Y182.  
 Brzustowicz: Federation, navigator on *Yorktown*, *What Price Victory?*; SL101, Y165.  
 Buckner: Federation, Human. Chairman of the Council at the time of the Battle of Olsen's Reach; SL111, Y174.  
 Burgess, Harry S: Federation commander, skipper of police ship *Masterson* Y173, *And to the Republic*; later commanded a frigate and an NCL, both of which were lost in action, *Day of the Eagle*.

C

Caladislus, Teric: Romulan Pente-Centurion, member of Crusia Malak's Praetorian Team, Y164.  
 Capelli: Federation ensign, on *Excalibur* when it was thrown into a strange space warp, *Duel Escape*.  
 Carlos the Slime Devil: Terrorist, SL10, Y166.  
 Cartwright: Navigator on Hydran FF *Goodwind* in Magellanic Cloud, part of Warlord Tri-Video series, *Volunteers*.  
 Cat-of-Five-Stars: Kzinti Admiral commanding forces attacking Lyran base in SH88, Y180.  
 Cat-of-the-Dawn: Kzinti Captain who first employed scatterpack shuttles in Y81, SP1320.  
 Cat-of-the-Trees: Kzinti Captain first rank commanding the BCH *Pentarchy* in SH88, Y180.  
 Cat-Who-Dreams: Kzinti Captain 4th rank, Commander of the 3rd Drone Bombardment Group, disgraced in battle with Klingons Y161, SH54.  
 Cat-Who-Fought-Fuzzy-Bear: Kzinti commander during Operation Remus, Y181, SL74.  
 Cat-Who-Hunts Mastadon: Kzinti Captain of the CM *Carnivore* in SH90, Y182.  
 Cat-Who-Is-Resolved: Kzinti captain of CCX *Hypermass* fought Usurper X-squadron in Y186, SH118. Presumably KIA.  
 Cat-Who-Sleeps-With-Dogs: Kzinti Admiral. Commander of Kzinti forces SH16, Y181. He was secretly negotiating with the cluster on behalf of the Count. Commander of Kzinti forces at Operation Cavalry; SH11, Y182.  
 Cat-Who-Sleeps: Kzinti Captain 5th rank, commanded FV41; Y166, SH5.  
 Cat-Who-Snarls: An ethnic Kzinti in the WYN cluster. Was the executive officer of the *Black Dragon* on its mission in Y182. *The Long Road Home*.  
 Cat-Who-Stalks: An ethnic Kzinti in the WYN cluster, Colonel. In Y182, he made a deal with the Orion Daven Cartel for delivery of Romulan weaponry. *The Long Road Home*.  
 Cat-Who-Waits For Stars: WYN an ethnic Kzinti, Captain of the WYN OLR *Shadowfox*.  
 Cat-With-Favorable-Stars: See Usurper. Mentioned in *Cold Front*.  
 Chalmers: Federation Ensign, Pilot of Ghostlight #5, KIA? in *Ghostlight: Day One*.  
 Chandler: Federation leader of the Excalibur Templars, a Prime Team including Alexander and Church.  
 Chief Engineer: "Character" used in *Cadet Training Manual*.  
 Chromin: Orion commander of Windstar base at Denebola IV and simultaneously captain of CA *Gullwind* in Y173, in league with Romulans, *Encounter at Denebola*, SL89.  
 Chuikov: Federation lieutenant, senior officer on emergency bridge of *Lexington*, detached saucer section and dove it into the atmosphere of Beta Cygnax to save the crew but

had feelings of guilt and depression over leaving 150 crewmen in the rear hull, tried to commit suicide, *Surprise Reversed*; SL90/SH2, Y173.  
 Church: Federation member of the Excalibur Templars, a Prime Team led by Chandler, female.  
 Cilya: Orion, communications and sensor officer on Windstar Base in Y173, *Encounter at Denebola*; SL89.  
 Citrall: Federation ensign on BCF *Forrest* in Y182, *Betrayal*; SL143.  
 Clawfist: Lyran Captain, Commander of CC *Golden Crown*, *Too Close to the Flame*; SL144, Y181.  
 Clawraker: WYN, ethnic Lyran. 1st officer of the WYN OLR *Shadowfox*.  
 Clearwater: Federation, helmsman on NCL *Prince of Wales* in Y173: KIA? *Encounter at Denebola*: SL89.  
 Cline, Jeff: Federation, Human. Doctor on the Federation frigate *Chadwick*, KIA in Y179 story *Hold Until Relieved*.  
 Cocherl: WYN Duke commanding first WYN forces in Y181 battle against Lyrans SH16.  
 Collins, Dennis: Federation CPO, a logistics and supply supervisor on tug *Copernicus*, frequently plays roles, such as the aide-de-camp of the Marlovian ambassador, so that he can be rescued as part of training exercises; Y164.  
 Commander, The: Instructor at Federation Academy, promoted to Captain.  
 Conroy: Federation freighter captain in Y173, *Encounter at Denebola*.  
 Corda: Kzinti science officer on Q-ship *Phantom* in Y180, *Frontier Patrol*; SN11.  
 Corelli: Federation, weapons officer on *Yorktown* in Y165, *What Price Victory?*  
 Crater, Judge: Famous missing person from Earth history, mentioned in *The First Round*.  
 Credenza, Big Al: Orion pirate, N14 Academy, captain of CR *Berol Turquoise* UL3, was ambushed by Kosnett SL82, led Kosnett into ambush by Deth O'Kay SL83.  
 Crete, Bob: Federation pilot of Ghostlight #2 and wingman for Ghostlight #1 in Y172, KIA? *Ghostlight: Day One*.  
 Croll: Orion pirate of Penzance cartel, Romulan; Character in *Sending Gerard Home*.  
 Cromwell: Sensor operator on the *Doomsday Exchequer* in *The Battle of Olsen's Reach* CL#8.  
 Ctharrl: Kzinti Captain 2nd Rank of *Quasar*, fought Lyrans in Y165 SL132, *Cold Front*. Killed defending the Kzinti homeworld.

D

D'Naars: Member of a Prime Team, mentioned in CL#14.  
 Dace: Klingon; Marine on the *Vandal*, *Escape From the Holdfast*; killed in action.  
 Dardis, Caim: Gorn, first officer on *Reptilicon* in Y167; *Refiner's Fire*; SL25.  
 Darwell, Alice: Federation lieutenant; communications officer on *Lexington*; *Refiner's Fire* SL25; *Surprise Reversed* SL90/SH2.  
 Davenport: Federation, individual determined to have logged onto a computer terminal when she was not present.  
 Delveccio, Laura: Federation sensor sergeant in Y161, *Behind the Glory of the Heroes*.  
 Desius: Romulan sub-commander, captain of *White Hawk* in Y180; *First and Future Shock*; SH44.  
 Dewsnap, Richard: Federation captain of BCG *Australia* in Y183, apparently her only captain; SH23.  
 Dianna: Romulan Sub-Commander; Captain of *Praetorian* in Y167; *Refiner's Fire*.  
 Dibi, Karen: Human; Federation F-8 pilot in Y172; later married Matt Oberu; finally posted to a training base on Mars; *Ghostlight: Day One*.  
 Divelbliss: Federation Captain of the NCL *Richelieu*. Mentioned



(KIA?) in Hold Until Relieved.

Domaric, Arinius: Romulan Centurion, member of Crusia Malak's Praetorian Team in Y164.

Doran, Layla: Federation Commander, Briefing Officer of the *Suffolk* in Y164, former member of the White Tigers Prime Team.

Drykor: Federation Ensign, Tellerite, communications officer on NCL *Prince of Wales* in Y173, KIA?, Encounter at Denebola SL89.

Durents, John: Federation human who accompanies Dr Pasternak to Sentries, killed.

Duvalle, Francois "Frank": Federation Lieutenant, weapons officer on *Lexington* in Y173, Surprise Reversed; SL90/SH2.

## E

Engles, Burt: Federation farmer on Rita's Planet, only survivor of Klingon raid in Y164, testified to Organians; SL62.

Ericksen: Federation member of *Ramilles' Redoubtables* Prime Team in Y166, A Sense of Obligation.

## F

F'Marr: Federation critically injured crewman on *Republic* Y173, And to the *Republic*.

Fallon: Federation, officer on *Republic* in Y173, And to the *Republic*.

Fellus: Kzinti, captain of Q-ship *Phantom* in Y180, Frontier Patrol, former escort captain.

Fergusson, Gerald: Federation, Captain of *Excalibur* when it was thrown into a strange space warp, Duel Escape.

Ferrington, Terry: Human Cultural Attache on Debrock in Y172, kidnapped by AARPFs and rescued by Prime Team.

Ferris: Federation marine lieutenant in Y73, *Lexington*, Surprise Reversed; SL90/SH2.

Ffarric: Lyran count, Blood Star County, as of Y167.

Fikrohn: Lyran Arch Duke, supported LDR in Y145, SH122.

Flavius: Rom, Sub-Comdr, FF *Wolf* in Y173, And to the *Republic*.

Fong: Fed, helmsman on *Yorktown* in Y165, What Price Victory?

Frannic: Lyran, Captain of BC *Djinn of the Desert*, given command because he was the son of a noble house, killed in action Y171, Brothers; SH40.

Fregessan, Hans: Federation Lt Cmdr captured by Tholians in Y159 while serving on the spy ship *Ubichi Ranger*, rescued by Federation forces in Y166, A Sense of Obligation.

Fregessan, Sven: Federation officer who served on DD *Xerxes* in Y159, later promoted to Captain and served as Commander of CA *Ramilles* in Y166, used his command to conduct unauthorized rescue operation in Tholian space, SL148, cashiered and reduced to rank of crewman 3rd class in Y167, A Sense of Obligation.

Frinkor: Lyran Arch Duke, Foremost Duchy, as of Y167, mentioned in R14.

## G

G'vvan: Kzinti communications officer on FH206 Too Close to the Flame; SL144, Y181.

Gafib: Tholian, Base Planner on Base Station #2 in Y148; Escape from the Holdfast CL#8.

Gaius: Romulan, commander of Tholian border squadron in Y177, SL85.

Garth, William: Commander of GSC/CVL *Darwin*, discoverer of the Andromedan RTN network in Y195; SH166.

Gatlin: Fed; Ensign in Y168, *Excalibur*, Objective Juggernaut; SL1.

Gerard, Will: Federation, Human; sole survivor of planet raided by Kzintis. Raised by Kzintis, later returned to Federation and attended academy. Later sent to observe Kzinti fighter tactics because he spoke the language. Captured by pirates while serving on police ship, character in Sending Gerard home.

Gileski: Captain, Federation DD *Xerxes* Y173, Encounter at Denebola, SL89.

Glavius, Mal: Romulan sub-commander, Captain of King Eagle *Audax* Y173; KIA against *Republic*, And to the *Republic*; SL88.

Gloiu, Pelagius: Romulan Decurion, navigator of *Audax* in Y173, KIA against *Republic*, And to the *Republic*; SL88.

Goldman, Scott: Federation Major, headed a Prime Team in training whose mission suddenly became real when the Romulans turned up, Y164.

Goldsborough, Richard G: Federation captain of NCL *Prince of Wales* in Y173, temporarily captured by Orions, freed by spy, hero of battle, Encounter at Denebola, SL89.

Gorst, Kand: Klingon LtGen commanding 317th ground forces division, KIA, gave command to Kobol; SL58.

Gort: Executive Officer on D7 *Merciless* Y174, Betrayal; SL143.

Gr'brp: Marshal, chief of security on Debrock in Y172.

Graif: Tholian Worker Prime (executive officer) in Y149, Commanded the cruiser *Arrakk* while Jirrin commanded the fleet in Escape from the Holdfast; SL109, SL110.

Gran: Federation, captain of Q-ship, SG34.

Gray, Donald: Federation rear admiral, in Y195 commander of CX *Paris Commune*, A Meeting of Giants; SL98.

Grey, Richard: Fed; Commodore; Captain, *Excalibur*, Human, British; Objective Juggernaut Y168, SL1. Fought Tholians to rescue *Ares* in Y168 SN10/SH59.

Greymane, Felna: Orion; Captain, CR *Gossamer Phoenix*; Y168; Objective Juggernaut, SL1. Character appearing in Sending Gerard Home.

Grimes, Jackson: Federation merchant captain, trader, spy in Y173 who discovered Romulan attack plans, Surprise Reversed.

Grith: Klingon; Marine on the *Vandal* in Y149, Escape From the Holdfast; killed in action.

Groll: Communications officer on D7 *Merciless* in Y174, Betrayal.

Grrav'en: Kzinti Admiral who assigned K'rrral and Brr'ev to the FH206 in Y181, Too Close to the Flame; SL144.

Grrrof: Personal name K'rrral, Too Close to the Flame.

Gy'yp: Native of Debrock, a former member of the AARPF, but no longer active in Y172.

## H

H'lor: Navigator on FH206 in Y181, Too Close to the Flame; SL144.

H'rrora: Kzinti Commander 5th, operations officer of the FH206 in Y181, promoted to Captain 5th and assumed command, Too Close to the Flame; SL144.

Hacker: Orion pirate in Hamilcar cartel, Klingon, character in Sending Gerard Home.

Hamilcar, Barca: Orion cartel leader, mentioned in SL52.

Hamilcar, Daxar: Son of Orion cartel leader, captured by Klingons in Y165, rescued; SL133.

Heim: WYN Count commanding WYN reinforcements in Y181 battle against Lyrans SH16.

Hel-Hyan: Hydran captain of *Tenacity*, originally founded the HAWKS.

Hensen, Fred: Federation, lead repairman on *Yorktown*, KIA, What Price Victory?

Hisher: Hydran Admiral briefly assigned as head of Bureau of Ships R9.N1, retired about Y175.

Honest Abdul: See Abdul, Honest.

Hort: A spy who tried to spread treason in Shana's caravan and was murdered for his efforts, Within the Glove.

Howard, Albert: Federation Captain, commanding CA *Saratoga*.

Howell, Nita: Fed; Commander, skipper of CL *Texas*, Fought Klingons at Vanacek-VI Y155 SH50. She was decorated and promoted to a staff position.

Hr'grt: Planetary President of Debrock, a neutral planet within



the Federation in Y172.

Hrish: Tholian; Worker Prime (equivalent of First Officer) on the *Solitude* in *Escape From the Holdfast*.

Hultz: Hydran Admiral on Klingon front in Y183 quoted in R9.57.

Hunter, Merrin: Federation, Captain, *Yorktown*. Fought Klingons Y166 SH36 and again in *What Price Victory?* SL104.

Hydraxan IX: Last Hydran king before Klingon conquest.

Hydraxan XI: Hydran King who liberated the kingdom from the Klingons in the campaign of Y135.

Hydraxan XVI: Fourth Hydran King within one year period of civil war in Y141.

Hydraxan XXIII: The Great Hydraxan, died just before Hydrans entered the General War.

Hydraxan XXIV: Hydran ruler in Y175; R9.1.

Hygraphht: Hydran, captain of *Concept*, fought Lyrans in *Brothers*.

Hypantspts: Hydran Admiral, SL72.

Hyrth: Hydran, engineer on *Concept*, *Brothers*.

Hyspathh: Hydran, fighter pilot on *Concept*, brother (sister?) of captain Hygraphht, killed in action; *Brothers*.

I

Iblis: Lyran count, Night Star County, as of Y167.

Ikkrik: Tholian on base *AKK-10* tasked with feeding prisoners, *A Sense of Obligation*.

Iltho: Jindavo who plotted against Shana, *Within the Glove*.

Imarat, Yezzir: Head of Leebyahhn military; SH12.

Irvine: Federation LT, Science officer on *Forrest*, *Betrayal*.

Isahara, Fumio: Federation human who accompanies Dr Pasternak to Sentries. Killed.

J

J'van: Kzinti crewman transferred from FH206 back to FF183, *Too Close to the Flame*.

Jacobs, Ken: Federation, Lt Commander, navigator on the *Republic*, *And to the Republic*.

Jal: Jindavo who plotted against Shana, *Within the Glove*.

Jan: Wife of Bluebird Six, *Patrol*.

Jartrin: Klingon; Marine on the *Vandal*, *Escape From the Holdfast*.

Jeffries, Ian Alexander: Federation, captain of *Republic*, *And to the Republic*. Promoted to Commodore and transferred, hand picked Jeffrey Shannon as his successor on *Republic Betrayal*.

Jel: Jindavo murdered by Shana, *Within the Glove*.

Jenkins: Federation Yeoman, computer specialist from the frigate *Chadwick*, KIA in Y179 story *Hold Until Relieved*.

Jirrin: Tholian Captain, Sector Commander, commander of *Arrrakk* and Tholian units in *Escape from the Holdfast*.

Johansen, Erin: Federation Lieutenant, science officer of *Excalibur*, thrown into a strange space warp, *Duel Escape*.

John, Prince: See Prince John.

Jones, Horatio: Federation, Captain of *Exeter*, *The First Round*.

Jorgensen: Human; deck crew chief, *BATS 7*; *Ghostlight*: *Day One*.

K

K'rral: Kzinti acting Commodore 5th in Y181 in Command of FH206 *Hollow Tooth*, previously failed as Commander of cruiser *Death Claw*. Previously commanded SF131 *Cat's Eye*. Failed a second time and promoted to Admiral 5th. Personal name Grrof, *Too Close to the Flame*.

K'trenn: Klingon; Admiral; former captain of *Vandal*; mentioned in *A Warrior's Death*.

K, Captain: Name used by Federation Cadet Kaufman commanding Klingon ship in training simulator, N5.

Kadama: Lyran Duke, Far Stars Duchy, as of Y165. Opposed war plans with Hydrans, *Cold Front*.

Kagan, Sarl: Klingon, science officer on *Thunderchild*.

Kagan: Klingon, Captain of the D7 *Antagonist*, *A Tactical Point*,

*Tactics Manual*, SH1.

Kahl: Klingon Lieutenant, attended *Brotherhood Banquet*.

Kaleen, Thad Vak: Klingon senior officer. Simultaneously held ranks of Commodore in Deep Space Fleet, Major General in Ground Forces, and Count in the Klingon nobility.

Regarded as one of the most intelligent and intellectual Klingons; held several university degrees and was known to speak several languages. Negotiated the Klingon-Romulan alliance. Often used diplomatic cruiser D7N *Dictator*. See in SH80 Y171. He was present at the ceasefire talks that collapsed at the Battle of Olsen's Reach.

Kallon, Borzad: Klingon, captain of *Defiler*, previously served as first officer under Kormather; father died in experimental transporter; apparently KIA, *Where Wisdom Fails*.

Kalosh: Klingon, chief engineer on *Pitiless*, *What Price Victory?*

Kalp: Jindavo killed by Jinbaro Shana, *Within the Glove*.

Kang: A famous Klingon admiral, a ship was named for him.

Kanjorski: Klingon ensign, attended *Brotherhood Banquet*.

Kann: Klingon ensign on *Pitiless*, KIA, son of Kaita Kor, *What Price Victory?*

Karg: Klingon, commander of frigate squadron, F5C *Storm Leader*, *First Command*.

Karin: Lyran count, Doom Star County, as of Y167.

Karmon, Bocar: Klingon Chief Constable (ISF Commodore), Knight of the Sword, Commanded frigate *Interdiction* in battle against Orion PFs SH13. Was posthumously elevated to Baron of the colony planet Saganellia.

Karpf: Klingon ensign, attended *Brotherhood Banquet*.

Karsh: Klingon, commodore, commander of IKV *Invincible*, SH94, Y197.

Karten: Captain of F5 *Fire Angel*, *Betrayal*.

Karvic: Klingon, captain of *Scorn*, from *Escape From the Holdfast*.

Kasomia: Klingon; Executive Officer on D6 *Carnage*; demoted due to politics and giving poor advice; later served on *Vandal* as Senior Watch Officer; finally promoted to Executive Officer on *Vandal*; *Escape From the Holdfast*;

Kasrin'Jazal: Cygnan Technical Consultant on Debrock in Y172, kidnapped by AARPFs and rescued by Prime Team.

Kass: Klingon, female, security officer on *Thunderchild*.

Katagnic: Klingon mutineer, KIA, *Where Wisdom Fails*.

Katak: Klingon lieutenant, attended *Brotherhood Banquet*.

Katinski, Anna: Federation Captain, Commander of *Forrest* during Operation Remus, KIA, *Betrayal*.

Katrell: Klingon watch officer, presumed KIA, border station 13; *Where Wisdom Fails*.

Katsunaga, Toshiro: Fed; Helmsman, *Excalibur*, *Objective Juggernaut*.

Kaufman, Kenneth (Ken): Federation officer. As a cadet, he proposed the tactic that became known as the Kaufman Retrograde SG32. He later reached the rank of admiral.

Kault: Klingon officer, served on *Thunderchild*.

Kausch: Klingon Lieutenant, attended *Brotherhood Banquet*.

Kavek IV: Klingon Emperor at start of General War, noted in N15 ad for Federation And Empire.

Kavorian: Klingon Commodore in charge of Tholian Harassment Squadron Y179 after Operation Nutcracker, SH43.

Kay: See Deth O'Kay.

Kazinski: Klingon ensign, attended *Brotherhood Banquet*.

Keifert: Klingon ensign, attended *Brotherhood Banquet*.

Keim: Klingon, disruptor officer on *Thunderchild*.

Kelix: Klingon, chief engineer on *Thunderchild*, father of Kelleux.

Keller, Jarahn: Colonel, senior Prime Team testing officer at Prime Central in Y164. Plays Prellarian Null Grav Ball.

Kelleret, Sheroc: Federation leader of Highlanders Prime Team.

Kelleux: Klingon, succeeded his father Kelix as chief engineer on *Thunderchild*.

Kemas: Klingon; Lieutenant; Security Chief on *Vandal*, *Escape*



From the Holdfast.

Kenaal, Lord Mak: Klingon ambassador to the Lyrans before the General War, Cold Front.

Keng: Klingon, Captain of the F5 *Vandal*, later promoted to D7 *Pitiless*. KIA, What Price Victory?

Kent, Jerrod: Federation leader of Templars Prime Team.

Kenthias: Klingon, Lieutenant, executive officer and senior weapons officer on *Safeguard*, promoted to Lt Commander and given command of *Safeguard* upon promotion of Kiroth, *Escape From the Holdfast*.

Kenyon: Federation marine major on *Lexington*, *Surprise Reversed*.

Kerg: Klingon officer, served on *Gnasher*, transferred to *Voracious*, eventually becoming commander; transferred to *Thunderchild* as XO under Ketrick, eventually commander; transferred to C7 *War* as commodore; transferred to D7DX *Decimator*, KIA against Andromedans.

Keria: An ethnic Klingon, a former ESS officer who fled to the WYN cluster after falsely accused of a crime. Served as the security officer with rank of Lieutenant Commander on the *Black Dragon* during Y182. *The Long Road Home*.

Kerlin: Klingon, captain of *Conquest*, executed; see R8.15.

Kerr: Klingon lieutenant, attended Brotherhood Banquet.

Kerrn: Kzinti crewman transferred from FH206 back to FF183, *Too Close to the Flame*.

Kertoth: Klingon CO of F5 *Khedive* in *Escape from the Holdfast*.

Kervorian: Klingon, Commodore, in charge of the Tholian Border Squadron, SH43.

Ketrick: Klingon, captain of *Thunderchild*, later commodore on C7 *Death*, KIA during WYN cluster invasion of Y182. Tactical Training Officer in the Red Fleet; briefly mentioned in the Brotherhood Banquet, author of SH43 *Webbed Establishment*.

Kevar: Klingon lieutenant, mentioned *Where Wisdom Fails*.

Keyer: Klingon Lt Commander, acting Captain of *Destruction* Y166, SL138.

Khambars, Karilyn: Klingon officer, commanded an F5 against the Federation, was sent to the staff of the Red Fleet to await the opportunity for a new command, attended Brotherhood Banquet, served in a variety of positions under Admiral Ardak Kumerian including command of a new F5W at the Battle of the Cavalry Charge; later commanded B10S *Insatiable* as Commodore in SH94 Y197, mentioned obliquely in *A Meeting of Giants*.

Kicmol: Klingon lieutenant, attended Brotherhood Banquet.

Kidra: Klingon, commanded the E4 *Keeper* as a Lt Cmdr, KIA against the Orions, *Escape From the Holdfast*.

Kij: Klingon; Jr. Engineering Technician on *Widowmaker*, reads Tholian; appears in *Escape From the Holdfast*.

Kilgore: Klingon officer, known for his incredibly bad luck and his association with ships that underwent boom separation. The appellation "boom-boom" was provided by a Federation journalist and it is doubtful Kilgore ever heard it.

- Did cadet cruise on *Conquest* when it was captured by pirates.
- Served as a pilot on *Devastation*.
- Engineer on *Decimator* when it was lost in Romulan space.
- Served on *Darkslayer* when it was destroyed during battle with Juggernaut.
- Served on *Blackguard* just before it was captured by the Tholians and converted to TK5 *Exile*.
- Assigned to *Anarchist* but ship was lost before his arrival.
- Assigned to *Destruction* just in time for mutiny.
- Y175, staff officer on Hydran border where he arranged for convoy of booms SH107.
- Selected by Ketrick as replacement navigator for

*Thunderchild*, career got back on track, eventually commanded B10 *Invulnerable* SL97.

Killane: Marlovian Ambassador.

Killian: Klingon, Captain, D5 *Reaver*, SL98, *A Meeting of Giants*.

Kintor: Captain of D5D *Longbow*, *Betrayal*.

Kirientha: Admiral who repulsed Hydran breakthrough in Y138. Mentioned in *Escape from the Holdfast*.

Kirlov: Klingon Commodore, Commander of D7K *Merciless*, cut off in Romulan space for eight years Y174-Y182, eventually returned to Klingon space to Command a C7, *Betrayal*.

Kiroth: Klingon, captain of the E4 *Safeguard*, later promoted to full Commander and given command of the then-new F5 *Vandal*, *Escape From the Holdfast*.

Kiroth: LDR, mentioned as being the Captain of a ship during the Vandha campaign and killing a Lyran Noble in hand-to-hand combat, basis for LDR uniform design, LDR Uniforms CL#16.

Kiroth: Lyran. Chairman of LDR, after Mithau, before Pathau. Declared LDR independent in Y154, See R14, mentioned in CL#15.

Kirven: Klingon, lieutenant, third watch officer on *Pitiless*, KIA, *What Price Victory?*

Klafter: Klingon ensign, attended Brotherhood Banquet.

Klamax: Klingon security officer on an unspecified ship. *Gray Rations*.

Kleave: Lyran count, Hidden Dagger County, as of Y167, led raid on Hydran planet Hycoman in Y170, SH106.

Kleaves: Klingon, Marine commander on *Thunderchild*.

Kleig: Klingon, senior captain, D5L; mentioned *First Command*.

Klem: Klingon lieutenant, attended Brotherhood Banquet.

Kliv: Klingon; First officer, *Darkslayer*, *Objective Juggernaut*.

Klodhoppy, Moon-em-more: Ruler of Leebyahh, known as "Tinhorn" for reasons that are obscure, SH12.

Klor: Klingon marine officer, *Where Wisdom Fails*.

Knaguar: Klingon, captain of frigate *Audacity*; first in his class at the DSF Academy; *Bezwel Index Episode*, SL60.

Kobol: Slirdarian officer, highest-ranking non-Klingon, formal name: Razmond Kobol Tsumasoln. Mentioned in SL58.

Koda: Klingon Captain of D6J *Gehenna* in Y157 who led unauthorized attack on LDR SH125. Executed for exceeding his authority.

Kokomamie, lahtoldyouso: Head of Leebyahh church; SH12.

Kokrel: Slirdarian, marine sergeant on *Thunderchild*.

Kolandian: Klingon; Commander, captain of *Annihilation*; led attack on Kzinti 3rd Bombardment Squadron Y161 SH54. Attacked Kzinti carrier *Cutlass* in Y166 SH10.

Kolart: Klingon, Captain of D5A *Retainer*, attended Brotherhood Banquet.

Kollander: Klingon assistant engineer in *Two Views of the Klingons*.

Kolmen: Klingon Lt, attended Brotherhood Banquet.

Kolsen: Klingon, transporter officer on *Thunderchild*.

Komatsu, Rodney: Fed; Lt Cmdr, Chief Engineer *Lexington*; *Surprise Reversed*.

Konar: Klingon squadron commander, (on a D7C?), mentioned in *A Warrior's Death*.

Kopp: Klingon lieutenant, attended Brotherhood Banquet.

Kopus: Klingon lieutenant on D7 *Thunderchild*. Shuttle pilot.

Kor, Kaita: Klingon, commander, executive officer of *Pitiless*, assumed command on death of Keng, *What Price Victory*. Was previously the senior watch officer on the *Conqueror* and before that junior watch officer on *Devisor*.

Korath: Klingon; Commodore; Captain of *Darkslayer* and Commander of Tholian Border Squadron, caused more incidents with Tholians than Kumerian had, *Objective Juggernaut*; later commanded *Direslayer* when the Tholian Border Squadron was sent to the Kzinti border, later



became an Admiral.

**Korgal:** Klingon Commodore in command of the Tholian Harassment Squadron, Flagship *Darkslayer*, Based at Base Station #18. Was a Captain in Admiral's Kirientha's squadron when Hydran breakthrough was repulsed in Y138. Escape from the Holdfast.

**Korm:** Klingon lieutenant, *Decimator*, Refiner's Fire.

**Kormather:** Klingon, captain of *Fury*, presumed killed, Where Wisdom Fails.

**Korq:** Klingon; captain of the F5 Blackstar; attained command due to the influence of his father, Imperial Ambassador Torrka; Escape From the Holdfast.

**Kort:** Klingon, lieutenant commander (technical warrant officer), weapons officer on *Pitiless*, What Price Victory?

**Kosnett, Phil (Phillip):** Federation; Commodore on Klingon border and Captain of the command cruiser *Kongo*; named for his distinguished ancestor who was a diplomat in the late 20th century.

- Y160 he stopped a Klingon plot to crash an asteroid into a colony planet. SH3.

- Y161 his ship was sabotaged and attacked by Klingons SH1. During the same year, he fought the Klingons in the story A Tactical Point. Also that same year, he led the daring rescue of Federation hostages on a Klingon base SH7.

- Y162 he pursued the Klingon frigate *Audacity* during the Bezwel Index episode.

- Y163 he was conveying delegates to a conference when attacked by Orions SH67.

- Y164 he rescued the last survivor of a Klingon raid on a colony planet in the Neutral Zone and took him to Organia to testify against the Klingons SL62. That same year, Kosnett and his ship were propelled through a time warp and fought a brief battle with Gorns SN1.

- Y165 he rescued the scout *Bowie* which had been trapped behind Tholian lines SH130. This incident was mentioned in SL148 and in A Sense of Obligation as background.

- Y166 he raced to the scene when Orions attacked the Zeta Omicron base SL6.

- Y169 he set a trap UL3 for the pirate raider *Berol Turquois* SL82 but was in turn nearly trapped by the *Hammerfield* SL83.

- Y170 Went to Malarky system to negotiate for supply of Manurite to deny it to the Klingons, Two Views of the Federation.

- Y175 Commanded the cruiser squadron at the ceasefire talks that degenerated into The Battle of Olsen's Reach SL111.

- Y182 he was deputy commander of Alliance forces in Operation Cavalry in SH11 and SL131.

- Y183 he commanded a fleet on the Klingon front with the rank of Admiral; see SH23 and U5.

- Y184 he formed the *Flying Squadron* of X-ships.

**Kosout:** Klingon GIA officer assigned to Northern Fleet in Y182. The Long Road Home.

**Kosov, Marko:** Federation Commander, briefing officer on CA *Saratoga*.

**Kotheme:** Tholian; First officer, KIA, *Arrakk*; Objective Juggernaut.

**Kraal:** Lyran, Commander, first officer of BC *Djinn of the Desert*, resents captain Frannic, Brothers.

**Krain:** Klingon commodore, captain of *Direslayer*, mentioned First Command.

**Krak:** Klingon lieutenant, communications officer on *Decimator*, executed; Refiner's Fire.

**Kray:** Klingon Lt Cmdr, attended Brotherhood Banquet.

**Kreiger:** Klingon Lt Cmdr, attended Brotherhood Banquet.

**Krell:** Klingon, Lt on *Invincible*, SL98, A Meeting of Giants.

**Kremler:** Klingon, Captain of the F5 *Khedive*, later promoted to D7 *Gnasher*, SH3, SL62.

**Kren, Talos:** Klingon Count sent to negotiate peace with the Kzinti in mini-campaign T3 The Lone Gray Wolf.

**Kren, Threlvis:** Klingon officer commanding frigate squadron in Tholian Border Squadron, started incident with Tholians but didn't know when to take the victory and go home, SL64.

**Krendal:** Klingon, Admiral, commanded B10 *Invincible* in A Meeting of Giants SL98.

**Krill:** Klingon Lt. Commander, childhood friend of Kiroth, XO of the F5 *Vandal* and Commanded a captured Tholian PC in Escape from the Holdfast.

**Krilt:** Klingon, Captain, *Decimator*, Refiner's Fire.

**Kripet:** Klingon, lieutenant commander, second officer on *Pitiless*, KIA, What Price Victory?

**Kripney, Buckner "Ramrod":** Federation Major General who built the original Primary Contact Teams. Named the first team "Wraiths" because they were drained by training.

**Kripney, Irenia:** Wife of General Kripney.

**Kripp:** Klingon, Cadet, promoted to Lieutenant, Where Wisdom Fails; assumed command of the boom and brought it home in an as yet unpublished sequel.

**Kristak:** Klingon technical lieutenant in Two Views of the Klingons.

**Kriwal:** Klingon, Senior Watch Officer on *Abomination*, became acting captain after captain and executive officer were killed in action, Escape From the Holdfast.

**Kroal:** Klingon ISF Commodore of sector near LDR and commander of ISF F5P *West Warden* in Y157 when, based on erroneous information, he began a war with the LDR SH124. Afterwards, he was cashiered and dismissed from the service without even a chance to redeem himself on a Penal Frigate.

**Krogh:** Klingon ensign, attended Brotherhood Banquet.

**Krohl:** Klingon Lt Commander, chief navigator on *Thunderchild*, attended Brotherhood Banquet.

**Kron:** Klingon; Captain, *Vandal*; main character of A Warrior's Death. A colonial Klingon, Kron graduated from the academy and completed a familiarization tour on a battlestation, was assigned to the battlecruiser *Thunderchild*. After four years (reaching K2 but no higher because of his colonial background) he transferred to PFs where the opportunity for promotion existed. Given the high attrition in PF units, he quickly advanced to command a flotilla and reached rank K3, serving there several years. When his flotilla was wiped out (except for his ship) the entire crew of the G1L was transferred as a replacement draft to the frigate *Vandal* where Kron spent the rest of his career. This transfer was considered something of an honor. He eventually became a commander K5 and captain of the ship. He would have been transferred to a cruiser command except for his colonial background, which also prevented him from becoming a full captain K6. Kron was the son of the noble family that ruled his colonial planet and was addressed as Lord Kron. The *Vandal* and Kron disappeared in Y205 and were thought to have been lost in the explosion of supernova GC-1496-F.

**Kronn:** Klingon, first officer of *Defiler*, Where Wisdom Fails.

**Kronschnabel:** Klingon ensign, attended Brotherhood Banquet, later promoted to captain of *Dragonslayer*, fought against Andromedans in SL98, A Meeting of Giants.

**Krookshank:** Klingon chief engineer in Two Views of the Klingons.

**Kroree, Mak:** Klingon Lieutenant Commander, attended Brotherhood Banquet.

**Krotag:** Klingon Science officer on Hydran FF *Goodwind*, previously a member of a group known as "Pathfinders" during the "Trade Wars", part of Warlord Tri-Video series,



Volunteers.

Kruger, Karl: Federation, human, Marine Major on *Kongo*, SL60.  
Krull: Klingon admiral, mentioned in First Command Y176.

Klingon Lieutenant Commander of F5 *Tenacity* in Y166 SH36 may be the same officer.

Kruze: Captain in command of F5C *Ferocity*, led frigate squadron in attack on LDR in Y157 SH126.

Kryam: Klingon Lt. served as aid to Kiroth on Starbase #9 while new F5 *Vandal* being built, then Junior Watch Officer on the *Vandal*, and promoted to Senior Watch Officer at the end of Escape from the Holdfast CL#8. Had served as junior navigator on the D7C *Deathslayer*.

Kryle, Kallis: Klingon; First Officer of *Anarchy*; led mutiny on that ship; later promoted to XO on *Demonlayer*, was executed when his duplicity was discovered; SL115.

Krymeric: Federation chief medical officer of *Suffolk*. Y164.

Krystal, Susan: Federation, human, first officer of *Connecticut*, KIA, First Command.

Ktazh Miroov: Lyran Count, Night Roar County, as of Y167.

Kuhla: Lyran Count, Black Claw County, as of Y167.

Kuhr: Klingon ensign, attended Brotherhood Banquet.

Kulz: Klingon, ESS Captain. The senior ESS officer in the Northern Fleet in Y182. The Long Road Home.

Kumerian, Ardak: Klingon; SH5, SL2, SL3, SL64, N13 Academy; Probably the best known Klingon officer, but hardly a legend. Most famous for his philosophical quotes, such as "The only valid result is victory" and "Never fight a battle you do not have to win." Mentioned in Cadet Training Manual and in R3.R51.

- Graduated from DSF Academy in Y155,
- commanded frigate *Vigilance* in SH5. As a result of that victory, he was promoted to command D6 *Destruction* and sent to the Tholian Border Squadron for advanced combat training.
- Promoted to command Tholian Border Squadron in D7C *Darkslayer*. Led the attack on a Tholian base in SH6. Demoted to ship command after fiasco in SL64.
- *Destruction* mutinied in Y170, Kumerian was sent to command penal frigate *Insufferable*, later restored to command of *Destruction*.
- While in Command of *Destruction*, picked by Wing Admiral Korath to lead attack on Annox-V complex in Y178 SH104.
- Later promoted to deputy commander of Western Fleet in charge of combat training, then to commander of the Red Fleet (northern combat training command). Planned the ambush of the Kzinti drone cruiser *Onager* SH89. Took Red Fleet into combat in C8 *Victory*, defeated by Operation Cavalry and killed in action.

Kumerian, Katrina: Beloved wife of Ardak, mother of Kollos, died Y173(?).

Kumerian, Kollos: Klingon, Son of Ardak; Academy graduate, but was refused a commission in the Deep Space Fleet because his father was then in disgrace; became very successful PF group commander SH14, led PF flotilla against Operation Cavalry SH11; was present at Ardak Kumerian's last battle SL2; fled to WYN Cluster after defeat in SH153; later commanded PF forces in the WYN fleet.

Kupnil: Klingon; science officer, Vandal; A Warrior's Death N12, KIA.

Kurlak, Vulkalis: commander of Tholian border squadron, organized attack by hundreds of fighters, SL85.

Kurner, Kina: Klingon songwriter and singer. Wrote "Wolf Among the Lions" in honor of Kollos Kumerian and his 701st flotilla, mentioned in SH14.

Kurzban: Federation, Commander, navigator on *Prince of Wales*, captured with Goldsborough, Encounter at Denebola.

Ky: Klingon; Captain of the *Anarchy*; killed by mutiny; SL115.

Kynar: Klingon; Engineer, Vandal; A Warrior's Death KIA.

## L

L'ehn, Dohnmac: Rigellian Sgt, member of a Prime Team in training whose mission suddenly became real when the Romulans turned up in Y164.

Laarzdah: Lyran Duke, Enemy's Blood Duchy, as of Y167, successor to Larzhak.

Larid, Kyle: Federation, classmate of prime team in training whose image is used to lure one member to a carnivorous plant. Y164.

Lambeth, Vice Duke: nominal Lyran Commander and senior surviving heir of Duke Roget SH11.

Lammer: Federation crew member, critically injured, And to the Republic, CL5.

Largeau: Federation, Captain of FFE *Davout*; KIA, SL98, A Meeting of Giants.

Larkahn: Lyran Duke of Enemy's Blood Duchy, tried to retake LDR, KIA at Battle of the Long Claws SH122, see also R14.

Larzhak: Lyran Duke, Enemy's Blood Duchy, son of Larkahn, R14.

Larzhak: Lyran noble house mentioned in LDR Uniforms, CL#16.

Lau, Lin-tse: Federation Lt, Andorian, Behind the Glory of the Heroes.

Leelun, Kay: Crew member, possibly captain, of Orion ship *Lady's Diamond*, Betrayal.

Lessul'Tret: Did a survey of Sebelia IV.

Lestha: Female Klingon officer, Second in Command, KIA, *Doomslayer*, The First Round.

Leyraf: Lyran count, Apex County, as of Y167.

Lorias, Rafiato: Romulan Decurion, member of Crusia Malak's Praetorian Team in Y164.

Luxembourg, Danyel: Human Lt SG, member of a Prime Team in training whose mission suddenly became real when the Romulans turned up in Y164.

## M

M'eins, H'Ruusti "Rusty": Rigellian Sgt, member of Black Eagles Prime Team, once faced off with Marcus Tal one-on-one.

M'tanga: Federation lieutenant, communications officer *North Carolina*, KIA A Warrior's Death.

MacArthur, James: Fed; Ensign, in charge of navigation on *USS Hornet* during 'Ceasefire Collapse'. Also, caused collapse by activating *Hornet's* fire control during beginning of negotiations. The Battle of Olsen's Reach.

MacCullum, Regis: Orion commander of base Oneshot, mentioned, The First Round.

Mad Jack Nelson: Orion pirate, originally from WYN cluster, hosted a confused battle Y175 SH37.

Malak, Crusia: Romulan Ante-Tribune, commanded Praetorian element sent to capture Mizari'Jhot in Y164. Assisted Marcus Tal in his attempt to get Debrock to ally with the Romulan Empire in Y172.

Mallius, Fellesia: Romulan Pente-Centurion, member of Marcus Tal's Praetorian team on Debrock, Y172.

Mallory: Federation Admiral who put Shannon in command of *Forrest*, and sent *Forrest* on peace mission, Betrayal.

Martonson, Blake: Federation commander, first officer on the *Republic*, And to the Republic.

Mason: Federation Sgt used as example for damage determination example in Prime Directive rulebook.

Massi, Tumbull: General, Retired, father to Prime Teams, archivist. Selected original site of Prime Central at Moon Base 3.

Massing, Minx: Federation Lt, medical officer of Black Eagles Prime Team.

Mathers: Federation Ensign, Navigator of the frigate *Chadwick*



KIA in Y179 Hold Until Relieved.

Matthews: Federation Admiral, commanded Sixth Fleet on the first day of the Romulan invasion in Y173, was chosen for command because he would do his job without complaint (prior Sixth Fleet commander had complained publicly about the lack of ships to defend against Romulan aggression), relieved of command as scapegoat for Romulan invasion, court-martial convened but never tried the case, served remainder of the war as chief of logistics command, Day of the Eagle. Mentioned in SH97, Y173.

Maxillius: Romulan Praetor; present at ceasefire collapse in Y174; The Battle of Olsen's Reach CL#8.

McBryde, Ralph: Federation Captain, Commander of NCA *Dayton*. Y179, SH84.

McGuffy, Jon: Federation human who accompanies Dr Pasternak to Sentria.

McLean, Gail: Federation, communications officer on *Yorktown*, What Price Victory?

Meade: Federation Admiral on the Klingon-Lyran front; SH82 Y177.

Meister, Reinhardt: Fed; Lt Cmdr, Science Officer, *Lexington*; Refiner's Fire; first officer and science officer, Surprise Reversed.

Mell, Tanquar: Representative of Sevarian Alliance, kidnapped by F'Vaion Vax, rescued by Black Eagles.

Melorian, Thera: Federation Lieutenant commanding 2nd section of the Ghostlight Squadron VF-123, pilot of Ghostlight #7. Ghostlight: Day One. She went on to fly the F-14 and died in the same battle over Remus in which the carrier *MacAuthur* went down.

Menkowitz, Stan: Chief Cook of the *Copernicus* in Y164, frequently plays roles, such as the Marlovian ambassador, so that he can be rescued as part of training exercises.

Michaels, Sean: Federation Engineering officer on the frigate *Chadwick* KIA in Y179 Hold Until Relieved.

Miow: LDR Chairman, as of Y167, mentioned in R14.

Mitch: Federation officer on *Ramilles* Y166. A Sense of Obligation.

Mithau: First chairman of LDR, R14, mentioned in CL#15.

Mitzi: Fed, captain of battle station, Behind the Glory of the Heroes.

Mizari'Jhot: Cygnan scientist working on new method of tracking cloaked ships in Y164, pursued by Romulans.

Mizia: Klingon, Cmdr, ISF, attended Brotherhood Banquet, quoted there.

Mojard: Klingon Marine Force Commander on the F5 *Vandal* in Escape from the Holdfast CL#8.

Mok: Klingon; Marine squad leader on the *Vandal*, Escape From the Holdfast; killed in action against the Tholians.

Morison, Samuel: Federation Lieutenant Commander, historian writing history of General War. Interviewed Admiral Matthews in Day of the Eagle in CL5.

Moses: Operator for the Masters, The First Round.

Myekmahtuz: Andorian 1LT, member of a Prime Team in training whose mission suddenly became real when the Romulans turned up in Y164.

Myers: Federation member of *Ramilles' Redoubtables* Prime Team in Y166, A Sense of Obligation.

N

N'gtsuta: Federation, race unknown but has pseudo-wings, KIA, weapons officer on *North Carolina*, A Warrior's Death.

N'Jorn, Ted: Tax attorney for V'Thoon, Rescue on Roon.

Nagatori: Federation Commodore of Diplomatic Corps, traveled on *Forrest* to Oxvind-V to negotiate peace with Romulans.

Nar: Jindavo destroyed by Shana, Within the Glove.

Nash: Federation, commander, first officer on *Prince of Wales*, KIA at Denebola, Encounter at Denebola.

Nashar: Lyran count, Bloody Claw County, as of Y167.

Nelson, Mad Jack: See Mad Jack Nelson.

O

O'Dere, Maureen: Federation Lt Commander, chief engineer on *Republic*, And to the *Republic*.

O'Kay, Cabal: Orion, Human, Son of Deth O'Kay; captain of Orion X-ship *Spirit of Orion*.

O'Kay, Daniel Deth: Orion CA Captain; human, main character The First Round (CL3, missing section in N8); Character in N14 Academy, mentioned UL3; fought masters battle in SL50, attacked Klingon convoy in SL51, Betrayed by Hamilcar cartel in SL52, captured by Federation but rescued in SL53, attacked Federation convoy in SL54, involved in the Hunt for the *Berol Turquois* in SL82, SL83. Captured rear hull of Klingon ship *Conquest*; see R8.15. Deth O'Kay was a graduate of Star Fleet Academy, and was court-martialed for refusing to obey a lawful order he felt violated ethics.

O'Leary, Megan: Federation, Chief engineer on *Yorktown*, What Price Victory?

Oberu, Matt: Federation Lieutenant commanding VF-123 (the Ghostlight squadron) in the story Ghostlight: Day One in CL#9. Married Karen Dibi, later posted to Earth to train local defense units. Later promoted to Commander, given command of a training wing on Mars.

Onslow: Federation pilot of Ghostlight #11. Later shot down and spent several years in a Klingon prison camp. Ghostlight: Day One.

Osage: Federation Admiral; KIA on his flagship the CVB *Nelson* by an enemy raid in SH70.

Ovidi, Andrius: Romulan Ante-Tribune, member of Marcus Tal's Praetorian team on Debrock, Y172.

Ovo, Maximus: Romulan, chief engineer on *Audax*, KIA against *Republic*, And to the *Republic*.

P

Packard, Annette: Fed, captain of survey cruiser *Richard E Byrd*. Fought pirates in SL68; raided pirate base in SL108.

Papris, Sultan: Romulan Magna-Decurion, member of Crusia Malak's Praetorian Team in Y164.

Paradise, Dallas: Federation human who accompanies Dr Pasternak to Sentria.

Pasternak, Emil: Federation Archaeologist who violates Prime Directive to visit planet Sentria to dig.

Pathau: LDR Chairman in Y157 after Kiroth, before Miow, Y161, R14.

Patriarch: Title for Kzinti Ruler.

Pau: Federation marine sergeant, Behind the Glory of the Heroes.

Pearson, Emily: Federation, apparently science officer of CA *Ramilles* in Y166, A Sense of Obligation.

Pekoe, Jon: Federation, human, first officer on *Yorktown*, What Price Victory?

Peltier: Federation Lt Commander, leader of Black Eagles Prime Team, North American Indian decent. Graduated from Star Fleet Academy in Y166. Became leader of Black Eagles in Y173 after graduating from Prime Central with honors.

Perrzear: Lyran commander, attended Brotherhood Banquet.

Pharoah: Orion cartel leader, boss of Deth O'Kay; The First Round, SL51-54.

Pickett, George E: Federation Captain of the CB *Gettysburg* in Y177, SH82.

Pilerk: Proper name of the Lyran known as White Tip. Y182. The Long Road Home.

Plinne, Marrio: Romulan Major-Decurion, member of Marcus Tal's Praetorian team on Debrock, Y172.

Plylth: Hydran, communications officer, *Concept*; Brothers.

Pol: Jindavo murdered by Shana, Within the Glove.



Praetor: Title for Romulan Prime Minister.  
 Prekor: Lyran count, Predator County, as of Y167.  
 Prince John: Captain of Orion raider *Doomsday Exchequer* in The Battle of Olsen's Reach.  
 Prozhoti: Lyran captain of Red Claw cruiser *Sorcerer*, Cold Front; died in the assault on the Kzinti capital.  
 Pskof: Lyran, littermate of Pilerk/White Tip. From the ousted ruling family of the Predator County in Y182. The Long Road Home.  
 Pylghhit: Hydran, helmsman on *Concept*, Brothers.

## R

Raask: Lyran count, Golden Fang County, as of Y167.  
 Radey, John "Cracker Jack": Federation admiral commanding carrier group *Zhukov*, Rescued Federation Fleet in Y175 SH81; Commander who bet the General War on one battle at the Pleiades Turkey Shoot in Y184, SH17.  
 Ragma: Lyran Count, White Stripe County, as of Y167.  
 Rahrzakh: Lyran King-Emperor as of Y165-181?, Cold Front.  
 Rakhzan: Lyran King during LDR crisis, R14, SH122.  
 Rama: Romulan, sub-commander, skipper of KR *Hawk*; KIA, Refiner's Fire.  
 Red Baron Brothers: Orion pirates, mentioned in SL51.  
 Red Fur: Lyran renegade, commanded Orion convoy in the CR *Warbride*, T6.  
 Reins: Federation commander, captain of *Hen*, KIA, Patrol.  
 Remandi, President: Human female, president of a corporation sponsoring warlords, CL11.  
 Remus Maximus: Romulan admiral, attended Brotherhood Banquet.  
 Reynold: A Zilon from the planet Tharg who wears the Pennington Flash and is not to be trusted.  
 Rhodes: Federation crewmember who sent warning to Mizari'Jhot that DSLP 78 was under attack.  
 Ricca, Neil: Orion captain of CA *Heavensent*, Lion's Heart Cartel, The First Round.  
 Richardson, Walden: Did a survey of Sebelia IV.  
 Richmark: Captain of the Federation CAR+ *Hornet* KIA story The Battle of Olsen's Reach.  
 Rikzer: Federation shipyard superintendent, First Command.  
 Rippke: Lyran count, Dark Storm County, as of Y167.  
 Riven: Federation Lt, Weapons officer on *Forrest*, Betrayal.  
 Rivers, Charlie: Federation Ensign in Y159 aboard DD *Xerxes*, previously a fencing champion at Star Fleet Academy, A Sense of Obligation.  
 Roberts: Federation Lt. KIA Battlestation #10 In Y179 Hold until Relieved.  
 Roche, Olivette: Tri-Video producer famous for her conspiracy theories in Y203. Mentioned in SH156.  
 Rochelle, Walt: Federation Commander, XO of CA *Ramilles* in Y166, A Sense of Obligation.  
 Roget: Lyran Duke of Red Claw Duchy at the start of the General War. Led Lyran forces in SH16 WYN and the Lion and was killed in action. Mentioned in N13 Brotherhood Banquet in the past tense.  
 Rolandus: Romulan, nephew of emperor, proconsul in command of Federation front at end of war, launched civil war T10 against the Romulan Republic to restore empire, claimed title as Emperor.  
 Rolindra: Daughter of Rolandus, named figurehead Empress of the Republic after the Romulan Civil War.  
 Rzakh: Lyran count, Pelt Hunters County, as of Y167.

## S

S'Arnath: Gorn; sensor officer, *Reptilicon*; KIA Refiner's Fire.  
 S'Lenthna: Last heir of Hydraxan IX, virtual puppet of the guilds in the Lost Colonies during the Klingon occupation, counted in Hydran histories as Hydraxan X but never formally took

the throne, abdicated in favor of his grandson.  
 S'Leuthold: Gorn wrestling champion.  
 S'Teken: Gorn admiral; SL73.  
 S'Torc: Romulan Commander, squadron commander at battle of Denebola, captain of KRL *Conqueror*, Encounter at Denebola.  
 S'Toval: Gorn Flag Lt of Admiral S'Trenk, killed by Romulans in Y176 SH138.  
 S'Treleg: Gorn Admiral. While a young Lt Cmdr he commanded the BDD *Kalessin* in SL114. As an Admiral, he commanded Operation Cavalry; SH11. Mentioned in historical footnote SH101. Mentioned in SL131.  
 S'Trenk: Gorn Admiral, surprised by Romulans and killed in Y176 SH138.  
 S'Zhera: An individual who made it to a summit through the intervention of the Black Eagles Pirne Team.  
 Sarhadi, Sorria: Federation Lt SG of the tug *Copernicus'* engineering section in Y164, frequently plays roles, such as the daughter of the Marlovian ambassador, so that she can be rescued as part of training exercises.  
 Sataar: ISC, Korlivalar, helmsman on *Celestra*, First and Future Shock.  
 Scipio, Octavianus: Romulan Proconsul, commander on Gorn border; SL73.  
 Scofield, Jack: Federation, Commander of *Connecticut*, First Command.  
 Scorpio, Robert: Federation police commissioner, converted a police corvette into a carrier R2.24.  
 Secthane: Tholian; Wing Commander 3rd Patrol Squadron, KIA; SL3.  
 Sectin: Tholian; Commodore and Captain of the *Arrakk*. Promised Korath he would not interfere with destruction of *Excalibur*. Self-destructed to destroy Juggernaut; Objective Juggernaut, KIA.  
 Senar: Federation, Vulcan, captain of *Darius*, killed in action, Encounter at Denebola, SL89.  
 Septicus, Donaris: Romulan Ante-Centurion, commander of a marine detachment in Y164 assigned to assist Crusia Malak in the capture of Mizari'Jhot.  
 Seret: Vulcan writer whose primary treatise was the basis of the All Amphibian Revolutionary People's Front's revolution on Debrock in Y172.  
 Shallert: Federation Alpha-Centauran, ambassador on Debrock in Y172.  
 Shana: Jinbaro of a caravan, Within the Glove.  
 Shannon, Jeffery: Federation Captain, Commander of CA *Republic* when it was destroyed in Y181, then given command of BC *Forrest* in Y182, Betrayal.  
 Shaw: Federation, helmsman on *Connecticut*, First Command.  
 Siert: Vulcan Junior Ambassador on Debrock in Y172, kidnapped by AARPFs and rescued by Prime Team.  
 Simon: Helmsman on *Hammerfield*. Mentioned in First Round.  
 Snyder, Lee: Federation, helmsman of *Excalibur* when it was thrown into a strange space warp, Duel Escape.  
 Sonja: Female first officer on the *Doomsday Exchequer* in The Battle of Olsen's Reach CL#8.  
 Speerin: Federation, Commander of DD *Xerxes* in Y159, A Sense of Obligation.  
 Spenser, "Wild Bill": Orion Captain who first contracted the WYN Cluster Y136. Prime Directive.  
 Spiker: Orion; Captain of *Spiker's Retreat* SL51.  
 Srib: Slirdarian; Marine sergeant on the *Vandat*, killed in action; Escape From the Holdfast.  
 Sslith, Rexus: Gorn; Senior Commander, captain, *Reptilicon*; Refiner's Fire, SL25; rescued Stocker and Lexington, Surprise Reversed. Mentioned in Cadet Manual.  
 Sslith, Ssendar: Captain of unnamed Gorn CC, thrown into a strange space warp, Duel Escape.



St John-Smythe, Commodore David: Federation officer commanding the 3rd Battle Squadron in an alternative timeline SH166.

Stangkowski, Micah: Federation, doctor on *Republic*, And to the *Republic*.

Stanislaus: Orion, chief engineer of *Hammerfield*, SL54; mentioned as captain of *Spear of Orion* in the introduction to story The First Round.

Starn: Romulan sub-commander, captain of War Eagle *Challenger*, nephew of Taalar, KIA against *Republic*, And to the *Republic*.

Sterm: Romulan, brother of commander Tama, killed in action on KR *Kestral*, mentioned in Refiner's Fire.

Stevens: Federation Commodore, captain of CVS *Nelson*, mentioned, A Warrior's Death.

Stocker, Anthony: Federation, human, Captain, CC *Lexington*; Refiner's Fire. Appears in scenarios: SH2 Y173, SL53, SH80 Y171, U5.7; Violated neutral zone to attack Romulan Sixteenth Cohort just before war began after receiving advanced warning of invasion, Surprise Reversed.

Stoner: Member of a Prime Team, mentioned in CL#14.

Storr: Romulan sub-commander, captain of *Gyrfalcon* in Y173, assumes command after Taalar is killed, disengages and returns to Romulan territory unaware that a war is about to begin, And to the *Republic*.

Straight-Spike-Tail: Kzinti agent in the WYN Cluster. Responsible for the destruction of the WYN KE4 *Justice Denied* in Y168, SH77.

Strell: Romulan High Admiral; first member of triumvirate, mentioned; Refiner's Fire.

Subeus, Maximus: Romulan, captain of *Truncheon*, KIA.

Sullivan, Aaron: Federation Captain, commands the *Suffolk*. Y164.

Sunturo: Rutani, Chief of the 'Pig Clans' on Aliser VI, weighing 250 Kilos, once proposed to by a Federation representative by accident.

Surat: Federation President in Y172.

Surin: Federation, chief engineer on *Prince of Wales*, Encounter at Denebola.

Syverson: Federation Captain of the FFB *Marko Ramius* during fly-off competition with the DW.

T

T'Lara, Hue: Fed; Captain of *Hood* in Y163, SH129.

T'Pon;: Vulcan Lt psionics master, follower of Path of Mey'Lar, member of Black Eagles Prime Team.

Taalar: Romulan commander of King Eagle *Audax* in Y173, And to the *Republic*, KIA.

Tailus: ISC governor of Dastaal, First and Future Shock.

Tal, Marcus: Romulan Tribune, Commander of a Praetorian Guard Team, entered Praetorian service in Y160. Distinguished himself in the Sherioki Incident Y163. Team wiped out by Seeker in Y172 Web of Darkness. Schemed to get Debrock to refuse admittance to the Federation in Y172 with scratch team of replacements.

Tal: Romulan Tribune; commander of K5R *Centaurii* SH80 Y171.

Tal: Romulan; Sub-Commander; Captain of *Senatarian*, Refiner's Fire.

Talgar: Romulan Admiral; second member of Triumvirate, mentioned; Refiner's Fire.

Tama: Romulan Commander; squadron commander, KIA; Refiner's Fire, SL25.

Tarsh: Fed, Tellerite engineer on *Connecticut*; First Command.

Tavarsi: Romulan sub-commander, captain of police *Snipe*, Surprise Reversed.

Tellius: Romulan centurion, scanner officer on *Audax* in Y173, KIA, And to the *Republic*.

Thaddeus: Captain, Commander of Hydran FF *Goodwind* in Magellanic Cloud, part of Warlord Tri-Video series, Volunteers.

Thelahm: Andorian First officer of the Federation frigate *Chadwick*, KIA in Y179 story Hold Until Relieved.

Thomas, Kevin: Federation Commander, Captain of frigate *Chadwick* in Y179 story Hold Until Relieved.

Thomas: Federation Commodore in charge of Battlestation #7 probably KIA Ghostlight: Day One in CL#9.

Thompson: Federation, Commodore, Battle Station K4, A Warrior's Death.

Thorne, Temujin: Orion enforcer captain from Daven Cartel in Y182, Commander of *Revolution*. The Long Road Home.

Thragg: Gorn, chief medical officer on *Reptilicon*, Refiner's Fire.

Threllvin: Federation, Andorian; helmsman, *Lexington*; Refiner's Fire; Surprise Reversed.

Tiercellus, Marcus; Romulan officer. Tribune in command of Skyhawk-A *Battleaxe* in SL113 Scout Report. Commander of Squadron III-C, Report by Tiercellus. Admiral in SH138.

Tlav: Federation, Andorian, communications officer on *Republic*, And to the *Republic*.

Tor: Federation, navigator on CC *Excalibur*, Objective Juggernaut.

Tor: Officer on F5 *Fire Angel*, Betrayal.

Torin: A Jindavo in Shana's caravan, Within the Glove.

Torius: Romulan, scanner officer on *Wolf* in Y173, accidentally exposes Romulan position, And to the *Republic*.

Torm: Executive Officer on F5 *Fire Angel*, Betrayal.

Tormillus: Romulan sub-commander, captain of SkyHawk-G *Sabre*, KIA in self-destruction, Encounter at Denebola.

Torrka: Klingon Imperial Ambassador. His son Korq commanded the F5 *Blackstar* in Escape from the Holdfast.

Tragar: Lyran, helmsman on BC *Djinn of the Desert*, Brothers.

Traine, Leon: Federation merchant captain, *Merlin's Wand*, And to the *Republic*.

Trellis: Federation member of *Ramilles' Redoubtables* Prime Team in Y166, A Sense of Obligation.

Tremeris, Golsai: Romulan Ante-Decurion, member of Crusia Malak's Praetorian Team in Y164.

Trudeau: Federation Commodore in command of Federation forces in SL118, The Battle of Adanerg.

Turen, Drenkath: Socialist philosopher.

Turm: Romulan; staff officer; mentioned; Refiner's Fire.

U

Uncle Ardak: Term used for Klingon Admiral Ardak Kumerian.

Uncle Remus: Term used for Romulan Admiral Remus Maximus.

Usurper: Kzinti rebel in civil war; SL11-13; SH38. Formerly known as "Cat with Favorable Stars." His son and grandson kept the same title as rulers of the WYN Star Cluster. The term is a Federation translation of the Kzinti term for "true holder of the throne".

V

V'Thoon: Merchant on Roon, front for pirates, Rescue on Roon.

Valgan, Jark: Klingon commodore. Fleet commander in SL115. Mutinied when Y175 attempt to assassinate his boss failed, Mutiny on the *Demonlayer* SH62, presumably executed after capture.

Valli, Adirius: Wrote on pre-starflight Romulan social structures, one of the texts used by the AARPFs on Debrock.

VanMeers, Harrison: Federation Lt Cmdr, leader of *Ramilles' Redoubtables* Prime Team on CA *Ramilles* in Y166, A Sense of Obligation.

Varden: Vulcan Lt JG, member of a Prime Team in training whose mission suddenly became real when the Romulans turned up in Y164.

Ventrak: Sentrian, R'Tseera shaman.



Vickers, Paul: Federation Lieutenant, scanner officer on *Republic*, And to the *Republic*.  
 Vincent, Helene: Vice Admiral, Federation commander against Andromedans in Y195, SL98, A Meeting of Giants.  
 Virgil: Daven Cartel operations officer in Klingon sector in Y182. The Long Road Home.  
 Vrac: Romulan officer; *Senatarian*, Refiner's Fire.  
 Vriss: Tholian; Captain of the *Solitude* in Escape From the Holdfast; killed in the boarding action.

## W

Wayne: Son of Bluebird Six, Patrol.  
 Weidenaur, Dave: Human; Federation Multi-Role Shuttle pilot; killed in action; Ghostlight: Day One.  
 Wheeler: Federation member of *Ramilles' Redoubtables* Prime Team in Y166, A Sense of Obligation.  
 White Tip: Ethnic Lyran, a ship captain in the WYN fleet. Proper name Pilerk. Took the ship *Black Dragon* on its mission to obtain weaponry in Y182. The Long Road Home.  
 White: Federation Lieutenant on *Prince of Wales*, led crew in retaking the engineering deck, Encounter at Denebola.  
 Williams: Federation ensign, weapons officer of *Excalibur* when it was, thrown into a strange space warp, Duel Escape.  
 Williams: Fed, Rear Admiral, flagship *Reshadije*, commands second division of Sixth Fleet, also deputy commander of Sixth Fleet. Sent to Denebola on the eve of the Romulan invasion to make a deal with Orions. Encounter at Denebola.  
 Wilson, Trilosita (Sisha): Federation spy on Windstar base, rescued Goldsborough, Encounter at Denebola.  
 Wolf, Gerald: Federation Lt, KIA in Y179 Hold Until Relieved.  
 Wolfe, Robin: Alpha-Centauran female Captain, member of a Prime Team in training whose mission suddenly became real when the Romulans turned up in Y164.  
 Wright, Kelly: Federation sensor operator, main character of story Behind the Glory of the Heroes.

## Y

Y'zvar: Kzinti technician 3, member of Cabal, Too Close to the Flame.  
 Yankovnim, Tal: Klingon station commander, SH151.  
 Vax, F'vaion: Representative of Blaxians, kidnapped Tanquar Mell, captured by Black Eagles Prime Team.  
 Yefimov: Federation Fleet Captain, commanded Third Division of sixth fleet, ship *Potemkin*, Day of the Eagle; survived the initial Romulan invasion to become a major commander.

## Z

Zahn: Lyran count, Black Stripe County, as of Y167.  
 Zaob: Lyran count, Silver Moon County, as of Y167.  
 Zarab: Lyran, Count of Silver Moon County, mentioned in SH27.  
 Zarmoly: Something like a Tiger; do not grasp its tail; SL135.  
 Zegurnii, Karijm: Designer of Klingon fighters; see R3.90.  
 Zegurnii, Korobal: Son of Karijm, help design later fighters.  
 Zehrck: Last count of Lyran Dark Star County, R14 history. Murdered during the revolution.  
 Zh'Dronarzh: Son of Lyran King-Emperor Rahrzakh, killed in combat with Kzintis Y165, Cold Front.  
 Zh'Rahrzhan: Son of Lyran King-Emperor Rahrzakh, heir to the throne, Cold Front.  
 Zh'Tazharth: Seventh son of Lyran King-Emperor Rahrzakh, served as ambassador to the Klingons before the General War, Cold Front. Killed during an Andromedan raid on the Lyran capital.  
 Zor: Gorn, chief engineer, *Reptilicon*; Refiner's Fire.  
 Zul, Hissar: Gorn officer who became an Orion pirate, Stardust Cartel. Commander of raider cruiser *Zul's Annuity* and fought Andros in Y174 SH113.  
 Zusler: A Cromarg marine weaponer on an unspecified Klingon ship. Gray Rations.

INDEX OF GEOGRAPHIC TERMS:  
PLANETS, BASES, STAR SYSTEMS, etc.

AARPF: All Amphibian Revolutionary People's Front, an organization on Debrock dedicated to installing a Marxist government by force, organized by Marcus Tal in Y172.  
 Aberdeen III: Site where a Federation Colony is abandoned without trace of colonists being found in Y105.  
 Aairsis IV: A planet inside the Federation (but not a member) which, in Y168, had acquired some Klingon weapons. The Klingons tried to recruit the planet as an advanced base, an effort which failed although it did force the Federation to use military force; SL139.  
 Aklar III: Site of the Klingon Ockt-Tah academy where Dagger Teams are trained.  
 Aliser VI: A planet where the Federation negotiated with Sunturo, chief of the 'Pig Clans'.  
 Allen's Planet: In Fed-Kzinti neutral zone, raided by neo-samurai cult in Y145, population slaughtered. Home of Will Gerard.  
 Alpha Zeta: Federation asteroid mining station in Thetis star system, near Klingon border, used for intelligence listening post, suffered reactor problem, What Price Victory?  
 Altroth: One of three Hydran Lost Colonies.  
 Andichron 6: A planet that was rescued from renegades by the Black Eagles Prime Team.  
 Andor: Federation planet, home of Andorian race.  
 Ankrogea: Planet surrounded by maze; SL87.  
 Annox-I: Federation asteroid mining base in Annox system mentioned as heavily damaged in a raid SH104.  
 Annox-III: Federation asteroid mining base in Annox system mentioned as destroyed in SH104.  
 Annox-V: Location of a Federation asteroid mining base in Annox System. Raided by Klingons in Y178; SH104.  
 Annox: An unusual system in Federation space consisting of asteroid rings in each planetary orbit with no planets, extensively mined.  
 Anthraxan: Important Hydran star system.  
 Apex: Lyran county under Foremost Duchy.  
 Argon: Tholian base station. Attacked by Klingons in Y167 in SH95 and destroyed that same year in SH6.  
 Bakuria: Klingon warrior colony planet.  
 Bantarax: An uninhabited star system where Stardust Cartel found Andromedan units in Y174; SH113.  
 Bargantine: Klingon satrapy that becomes independent after the General War; UN1.  
 Base Oneshot: Mentioned in First Round.  
 Bcalata: A site where a Lyran base was located that was infiltrated by Kzintis, mentioned in Too Close to the Flame.  
 Beta Cygnax IV: Gas giant where *Lexington* had its final encounter with a Battlehawk and War Eagle, Stocker used a fictional base in orbit around this planet as bait; Surprise Reversed.  
 Bezwel Index: Neutral planet in SL60.  
 Big Valley V: Federation planet beset by pirates; T4.  
 Black Claw: Lyran county under Foremost Duchy.  
 Black Stripe County: Lyran county under Red Claw duchy.  
 Blackfoot Pass: Asteroid system on Fed-Klingon border with "tunnel" for ships to cross border. Klingons discovered tunnel in Y183; in scenarios SL20, SL78, SH39. Shown on a special terrain map in Module B.  
 Blaxian: A race who sent a representative to the summit on Telyar 7.  
 Blood Star: Lyran county under Far Stars Duchy.  
 Bloody Claw: Lyran county under Enemy's Blood duchy.  
 Bolmark: Important Lyran star system.  
 Brr'ixton: A site assaulted by Kzintis at some point, mentioned in



Too Close to the Flame.

Cestus III: First meeting of Gorns and Federation, mentioned in Refiner's Fire.

Charybdis: Black hole near the system Scylla, SG57.

Chicago 4: Home planet of Kenneth Kaufman, inhabitants sleep 20 hours per day.

Codimark IV: Federation planet raided in First Command.

Dark Star County: Lyran county, originally part of Enemy's Blood Duchy, which became the LDR.

Dark Storm: Lyran county under Far Stars Duchy.

Darmot: Klingon star system near Hydran border, Where Wisdom Fails.

Dastaal: An ISC colony planet near the Romulan border, Romulan crew from *White Hawk* are interned there, First and Future Shock.

Delmac: Site of a battle between Gorns and Romulans; SH21.

Denebola 4: Gas giant, Encounter at Denebola, one moon is named Sidekick, orbited by Orion Windstar Base.

Diablo Canyon: Asteroid field in Federation space; T4. A pirate base was hidden there.

Disobe: Sector of Kzinti space near Lyran front, Too Close to the Flame.

Doom Star: Lyran county under Far Stars Duchy.

Earth: Home planet of humans, capital of Federation, HQ of Star Fleet; threatened by Igneous in SN7.

Eastern Market: A large open air market on the planet Debrock.

Enemy's Blood: Lyran duchy on the Hydran border.

Far Stars: Lyran duchy away from Kzinti or Hydran borders.

Farlin: Klingon star system near Kzinti border, Frontier Patrol.

Fire Gorge: Found in the swamps of Debrock.

Foremost: Lyran duchy in central area. The Duke of this duchy is known as the ArchDuke and ranks first among equals with the three other Lyran Dukes.

Fornax: Star system with Federation colony. Declared independence and accepted ISC protection in Y187; SH24.

Fort Kripney: Nickname for Prime Central.

Frakmark: Important Lyran star system.

Garar-VI: Planet in Lyran space, site of an ambush by Lyran forces of an ISC carrier group in Y188; SH155.

GC-1496-F: Star that went nova, A Warrior's Death. See R3.202.

Ghdar: Gorn word for homeworld. There are three of these, Ghdar-I, Ghdar-II, and Ghdar-III, which are in different planetary systems.

Gijard III: Gorn base raided by Romulans; SH28. Romulans retreated from it in SL136/SH159.

Gitaarn Nebula: Nebula in Kzinti space near the Klingon front; SL153.

Golan: Daven Cartel base in Klingon territory.

Golden Fang: Lyran county under Red Claw duchy.

Gordan's Planet: merchant base near Romulan border, And to the Republic.

Gorngella: Gorn planet attacked by combined Romulan and Klingon force in Y174, Betrayal.

Gornshima: Site of decisive sublight battle between Gorns and Romulans in Y39.

Greater Magellanic Cloud: Satellite galaxy exploited by warlords.

GSN: WN-R2694-J: Designation of a dust cloud near the Federation-Romulan border. Used as part of Project Ghost Watch.

Hesperius: Name of a Federation sector near the Romulan border; includes dust cloud GSN: WN-R2694-J and the Sebelia star system.

Hidden Dagger: Lyran county under Enemy's Blood duchy.

Hokan: Mining planet just inside Gorn border, site of Operation Tribune; SL73.

Holdfast: Tholian territory.

Hole in the Wall: Pirate base; SL108.

Homeworld County: Capital province of the Lyran Empire.

Hycoman: Planet used by Hydrans as an impromptu base area and raided by Lyrans in Y170; SH106.

Hydramax: Important Hydran star system.

Hydrax: Hydran capital planet and system.

Hydraxaport: Hydran base raided by Andromedans in Y190; SH26.

Hyurdju: Hydran colony raided by ISC; SL137.

Iridima: A neutral planet in the Federation-Klingon neutral zone with rich sources of Iridium.

Iridium: Metal vital to the construction of starships.

K't'tothos IV: Klingon mining planet. Scene of Y180 revolt; survivors fled with Orion help but recaptured; SH65.

Kadrak: Important Klingon planetary system.

Kangor: Important Klingon planetary system.

Kartal Nebula: Terrain feature in Kzinti space; SH162.

Keevarsh: Important Kzinti planetary system.

Klardon: Important Klingon planetary system.

Klegarine: Klingon planet; Scenario SL99 was fought near it.

Klinshai: Klingon home system, raided by Andromedans; SL97.

Kobol's Rock: See Rock.

Krooth: One of three Hydran Lost Colonies.

Kzintai: Kzinti homeworld.

Landfalk: Planetary system near Klingon-Hydran border, UN1, claimed by Bargantines.

Leebyahh: Planet once used as psychiatric asylum, now neutral; SH12; buys weapons from Klingons, favorite target of Federation fighter pilots looking for easy victories.

Lesser Magellanic Cloud: Satellite galaxy used as base by the Andromedans.

Lightning Vipers: Deadly snakes in the swamps of Debrock.

Lost Colonies: See Old Colonies. Hydran off-map region.

Lumien: Kzinti star system near Klingon border, mentioned in Frontier Patrol as having dilithium mines.

Lyrantan: Lyran homeworld and system.

M31: Galaxy from which Andromedans come; R10.1.

Mad Jack's Hole: Orion base in asteroid belt, site of a confused battle in Y175; SH37.

Magellanic Clouds: Two small galaxies near the Milky Way.

Marlovia: A political entity from which Ambassadors come.

Mars: Planet in Sol System, first planet colonized by humans and the second-most important human planet.

Meva Station: A desolate and forbidding spaceport on the edge of nowhere, mentioned in CL#14 and in Hidden Agenda.

Minxitith: One of three Hydran Lost Colonies; much of this planet was made uninhabitable in civil wars of Y101. The planet never fully recovered.

Moon Base #3: Located in the Oceanus Procellarum, site of Prime Central, originally the home of the Cultural Indoctrination Center, but the Center was moved to Tycho.

Morkedian III: Federation dilithium mining planet; Jindarians tried to move into the system in Y162; SH169. Raided by Romulans SH20 in Y172. Site of disastrous retreat in Y173; SH97.

Naramar 3: A planet that is the location of marine boot camp.

New Marseilles: Planet where Federation Governor attempted to conceal the existence of a primitive sentient race.

Night Roar: Lyran county under Foremost Duchy.

Night Star: Lyran county under Far Stars Duchy.

Novorosibirsk II: Federation shipyard, First Command.

Ockt-Tah: Klingon Dagger Team academy on Aklar III.

Old Colonies: Hydran colony planets never conquered by Klingons and Lyrans, basis for forces that recaptured Hydran territory after the occupation.

Oxvind-III: Planet near original Fed-Romulan neutral zone where the boom of the F5 *Fire Angel* was found, Betrayal.



Oxvind-V: Planet near original Federation-Romulan neutral zone selected as the site for peace negotiations in Y182, Betrayal.

Pelt Hunter: Lyran county under Red Claw duchy.

Phtho-3: Hydran planet, command base for destroyer *Concept, Brothers*.

Phyllos System: System on Klingon-Kzinti border, mentioned in *Where Wisdom Fails* as the site of a previous battle.

Pleiades: Star cluster, location of Turkey Shoot SH17.

Pollux IX: Federation planet target of giant meteor; SH3.

Ponderosa IV: Federation planet beset by pirates; T4.

Predator: Lyran county under Red Claw duchy.

Prime Central: The principal training academy for Federation Prime Teams, also known as Fort Kripney.

Rally Point Red: Name given to a site that both Coalition and Alliance fleets selected as an assembly area for damaged ships, resulting in a desperate battle between them in Y180; SP991.

Rampart: Kzinti battlestation built near WYN space late in General War, under direct control of the Crown Prince, on the border between the Duke and Count. Captured by WYN-Kzintis in Y186; T8S4.

Red Claw: Lyran duchy on the Kzinti border.

Rek'Yak Nebula: Nebula in Gorn space. Y177; SH98.

Remus: One of two Romulan capitals, destroyed when Federation CVA *MacArthur* crashed into it, mentioned in SL74.

Revlis: Planet in Romulan space that acts as a sort of free zone, Betrayal.

Rigel IV: Federation planet badly damaged by Romulans in Y177; SH63. That battle was famous as the first in which the Romulans lost a Condor.

Rigel: Star system in Federation with several occupied planets.

Rita's Planet: Federation agricultural colony in neutral zone; SL61, SL62.

Rock: Unidentified planet; site of Klingon-Kzinti battle; SL58.

Romulus: One of the two Romulan capital planets.

Roon: A Federation planet where an Orion group operated, *Rescue on Roon*.

S'Kree: Apparently a level of training for Shamans on Sentria.

Saganellia: Klingon warrior colony planet dedicated to ISF.

Sanguinax System: Site of a starbase in Romulan space. The starbase was destroyed in Y195.

Scylla: Planetary systems near the Charybdis black hole, the primary of which frequently discharges large masses into the black hole; SG57.

Sebelia IV: Planet in the Hesperius sector near Fed-Romulan border used by the Federation as a training range.

Sector 4, Quadrant 926: Place where Federation, Gorn, and Romulan borders meet; *Refiner's Fire*.

Sefaria: Klingon warrior colony planet.

Selnar: A star system in Klingon space. Klingon ships forced a Jindarian caravan out of the system in Y145; SH167.

Sentria: A planet, location of the Kam'Srit Riddle.

Sevarian Alliance: A grouping which sent a representative to the summit on Telyar 7.

Sheboygan III: Planet attacked by Planet Crusher; SM1.

Sherman's Planet: In neutral zone between Federation and Klingons, raided by D6 *Destruction* in Y169.

Shiloh II: Federation planet, destination of a convoy from Ponderosa IV in T4.

Shiltra Region: An undefined area where Shana ordered one of his ships to move, *Within the Glove*.

Shindar Valley: A location on the planet Sentria.

Sidekick: Moon of Denebola IV, *Encounter at Denebola*.

Sigma Draconis: Federation planet; SM4.

Signa: Planet in Federation, *Behind the Glory of the Heroes*.

Silver Moon: Lyran county under Foremost Duchy.

Skoleos: Federation member planet, but its citizens served only as mercenaries to the Gorns, providing most of their fighter pilots.

Southfork IX: Federation planet beset by pirates; T4.

T'Ver: Kzinti marine academy, *Too Close to the Flame*.

Tarrin VII: Federation base destroyed by Klingons, technicians evacuated by shuttle; SL92.

Telyar 7: A planet which was the site of a summit. Used as the destination of a hypothetical ambassadorial party in a training exercise in Y164.

Tharg: A planet from which Zilons come.

Thetis System: In Fed-Klingon neutral zone, Alpha Zeta mining station there, *What Price Victory?*

Tholia: Hollow Dyson sphere planet, home to the Tholians in Milky Way galaxy.

Tiberias: Important Romulan planetary system.

Tibernia IV: Romulan planet, loyal to Rolandus during the Civil War, site of battle in T10S3.

Tr'Tasta Rapids: Located on the planet Varya 9.

Tuscana: System including an asteroid belt which was selected as an assembly and repair area by the Gorns in Y176; SH105; raided by Romulans.

Tyson's Star: Planet in neutral zone, had both Federation and Klingon bases, which fought each other in Y169; SH134.

V'th III: A site mentioned as raided by Kzintis at some point, *Too Close to the Flame*.

Valoria: Klingon colony planet.

Vandha: Site of the second battle of LDR independence; SH123.

Vanecek VI: Planet explored by Feds in SL28/SH50; site of clash between Federation and Klingons.

Varya 9: A planet that is the site of the Tr'Tasta rapids.

Velstrya: Apparently a council which decides things on Sentria.

Verma, Mount: A location on the planet Sentria.

Vesuvius: Important Romulan planetary system.

Vetrised IV: Location where the Wraiths encountered energy creatures in Y92.

Vidalia: Planet mentioned in *Surprise Reversed*.

Vielsalm: Important Kzinti planetary system.

Volmark: Important Lyran star system.

Vronkett: Important Kzinti planetary system.

Vulcan: Home planet of the Vulcan race.

Walkuria: Klingon colony planet.

White Stripe: Lyran county under Enemy's Blood duchy.

Wind Star Base: Orion base at Denebola; SL89; site of action in *And to the Republic*.

Wyskoon: Gas giant in Hydran territory; site of battle in Y143; SH35.

Yank's Hole: Klingon station in SH151; mentioned in SH152.

Zamyran: Kzinti planet where Lyrans and Kzintis fought. Y180; SH87.

Zeta Omicron: Federation station attacked by Orions in SL6.

Zeta Psi: Planet on which Deth O'Kay was captured, SL53.

Zinthim Base: Gorn base mentioned in *Refiner's Fire*.

Zursk: System near Klingon-Kzinti border, *Frontier Patrol*.

## INDEX OF MISCELLANEOUS ITEMS

Admiral Kosnett's Flying Squadron: An X-ship detachment used by the Federation late in the General War. Notable for including an X-Galactic Survey Cruiser.

Ahg'Grubs: Non-venomous scorpion-like creature native to Sentria, *Prime Directive*.

Algoran, Treaty of: Y157, Gorn-Federation Alliance.

Alliance Fleet One: A combined Federation-Gorn Kzinti fleet during the General War. Served in Operation Remus.

Alliance Fleet Two: A combined Federation-Gorn-Kzinti-Tholian



fleet during the General War. Served in Operation Cavalry.

Alpha-Centauran: Federation member race, R2.1, dominated by females.

Amazons: Federation Prime Team composed entirely of Alpha-Centauran females saves the Federation president at the Susturia conference from assassination by Orions Y182.

Andorian Whiskey: Alcoholic beverage.

Andorian: Federation member race, R2.1. Tall slender bluish humans with antennae. See Prime Directive.

Antarean: Federation member race, Hold Until Relieved.

Arastoz: Monster in SM10.

Arcturian: Federation associate member race, Behind the Glory of the Heroes.

Articles of Agreement: Kzinti-Federation treaty.

Astralan Hammer Beast: A riding animal somewhat akin to a horse.

Avengers: Seltorian PFs. Fought Tholians Y185; SH116.

Banshee Ball: Klingon game, Nexus 13 Brotherhood Banquet. Kault excelled in this sport at the DSF Academy.

Banshee: Monster in SM13. Named for the strange wailing noise heard over subspace.

Baratry: The legal definition of stealing a starship and using it for purposes not approved by its owners.

Baron's Fleet: Kzinti forces in new territories away from borders.

Baron: Lowest-ranking of the four Kzinti nobles.

Battle Fleet: Federation fleet formed during the General War.

Battle of ..: Listed under the name of each battle.

Black Eagles: The: Federation Prime Team, had extensive service, members having fought Romulans, Lyrans, Klingons, the ISC, Gorn renegades, and Orions. Disrupted spy operations on DPS 119 in Y175.

Blood: Battle Group Blood, Klingon battle group built around C9A *Admiral Kruge* Y175; SH81.

Blue Fleet: The training command of the Klingon Southern Theater. Became a tactical formation late in General War.

Bounty Hunters: Name given to 701st Gunboat Flotilla; SH14.

C'cesrick: Kzinti chair akin to a bean-bag, Too Close to the Flame.

Cabal: Literal Stealth Hunting Team, Kzinti Prime Team, Too Close to the Flame.

Carrier Fleet One: Federation fleet formed during General War.

Cartel: Hydran trade or industrial conglomerate.

Cartel: Orion "tribe", one of several organized criminal units; see the map in R8.1.

Cavaliers, The: Federation Prime Team.

Cenchron: ISC time unit, First and Future Shock.

Centichron: ISC time unit, First and Future Shock.

Chron: ISC time unit, First and Future Shock.

Clans, Lyran: See list in Nexus #13 ship list; correct term is "county" not "clan".

Clans, Orion: See Cartel, which is the correct term.

CNN: Corporate News Network, in the Warlord Tri-Video series, a news organization that reported on the activities of the various corporations in the Magellanic Cloud, Volunteers.

Coalition: Alliance of Klingons, Lyrans, and Romulans during the General War.

Combined Fleet: A Coalition unit including Lyran, Romulan, and Klingon units.

Constable's Fleet: Kzinti fleet commanded by the Constable.

Constable: A senior position in the Kzinti High Command, responsible for suppressing internal rebellion. Not one of the nobles but nearly of their political and military power. Late in the General War, the Constable assumed a tactical command on the front lines.

Cosmic Cloud: Monster in SM4.

Count's Fleet: Kzinti forces on Lyran border.

Count: Title of nobility, used by Klingons (e.g., Kaleen), Lyrans (16 of this rank), and by one Kzinti noble (third of the four).

Cromarg: Klingon subject race, mentioned in SL58; dwarfs from a planet poisoned by radiation from a nuclear war two centuries earlier. Used as technicians and some serve as heavy weapons crews in ground forces.

Cross of the Great Hydraxan: The highest Hydran award, given only to the most successful commanders. Multiple awards are designated by the addition of stars, circles, and triangles (in that order). The highest award "The Cross of the Great Hydraxan with stars, circles, and triangles" is exceptionally rare; only five were awarded during the entire General War, three of them posthumously. CL11.

Crown Prince: Kzinti noble, heir to the Patriarchal throne, ranks higher than the four nobles.

Cygnan: Federation member race; R2.1. Pale skin (resemble human albinos), dark eyes, technologically advanced. See Prime Directive.

Death Probe: Monster in SM9.

Deian: Federation associate member race, Objective Juggernaut.

Delmac, Battle of: Romulan victory over Gorns in Y178.

Design Bureau: In the Klingon empire, the government owns all military production facilities. To maintain competition, several independent design bureaus work on each requirement for new equipment or ship classes. See Karelli, Kozenko, and Zegurnii.

Disintegrata: Klingon statement of philosophy, *Go boldly among the peace and tranquillity, and contemplate the joys to be found in genocide . . .*, Nexus 13 Academy. Probably Federation propaganda.

Divad Bradley: The company which makes Federation shuttles.

DSF: Klingon Deep Space Fleet (navy, star fleet).

Duke's Fleet: Kzinti forces on Klingon border.

Duke: Title of nobility, one of the four Kzinti nobles; the Lyrans have three dukes.

Dunkar: Klingon subject race, mentioned in SL58, orange skin, most trusted subjects, a handful of Dunkars have attended the Academy and hold DSF commissions.

East, Fleet of the: Romulan forces on the ISC frontier.

Eastern Fleet: Klingon forces on the Federation border.

Echelon of Judgment: ISC battle fleet consisting entirely of X-ships, returned to ISC capital barely in time to defeat Andromedan attack; see R13.1B. Order of battle is listed in R13.200.

Echelon of Justice: Second ISC X-ship fleet, never at full strength. In Y187, this force fought the Romulans at Tibernia IV.

Echelon: The standard ISC battle formation.

Energy Monster: Monster in SM11.

Entangler: Jindarian hand weapon.

Era of Tranquillity: Organian-enforced ceasefire, Y203.

Esperanto: Artificial human language used by Andorians in Behind the Glory of the Heroes.

ESS: Klingon Empire Security Service (secret police).

Estallian Fireweed: A harmless plant native to Roon, Rescue on Roon.

Expeditionary Fleet: Most of the races in SFB had a fleet of this designation during the General War.

Expeditionary Fleet: The Hydran fleet assigned to fight its way through the Klingons to reach Federation territory.

F'zeckt: Kzinti encryption system, Cold Front.

FBS: Federation Broadcasting System, a tri-video network that beams commercial programming across the UFP.

Fish Ship: A series of WYN warship classes with Federation codenames for predatory Terran fish built from Y180.

Fleet of Rolandus: A Romulan force late in the General War.

Fleet of the East: Romulan forces on the ISC frontier.

Fleet of Tiercellus: A Romulan force late in the General War.

Foremost: Lyran Duchy around homeworld.



Frignaut: Term applied to Klingon F6 frigate.

Galactic Intelligence Agency: Federation intelligence.

Galactic Research Unit: Klingon Intelligence.

General War: Conflict between 8 races lasting 18 years; major focus of Star Fleet Battles game system.

Ghobe'!: Klingon term for "Nope". Considered crude, but often used humorously.

GIA: Galactic Intelligence Agency, Federation intelligence.

Gidron: A large meat beast favored by Kzintis, *Too Close to the Flame*.

Glory Lists: All members of Prime Teams are entered into these lists which are displayed in the concourse of Prime Central.

Gorn Anchor: Maneuver in which a ship grabs the target with tractor beams before firing seeking weapons. This prevents the target from escaping or using a wild weasel.

Grand Alliance: Federation, Kzinti, Gorn, Tholian, Hydran alliance during General War.

Gratz: Slang from Nexus #5 Academy article.

Graveyard of Ships: An area in an energy-draining field that traps starships; SG53.

Gremlins: Small furry humanoids that seized the Federation GSC *Cousteau*. No trace of the ship's crew was ever found Y168; SH133.

Gribatz: Unidentified object Klingons might have up their sleeve; SL51.

Guilds: Powerful political, economic, and/or industrial groups within the Hydran Kingdom; R9.1.

Gunline: The forward row of ships in an ISC echelon formation.

HAWKS: Hydran Auxiliary Womens Korps. Female volunteer fighter pilots originally on the Ranger *Tenacity*.

Highlanders, The: A Prime Team which rescued the starliner *Celestial Queen* from Orions with no civilian casualties.

Hilidarians: Klingon subject race, mentioned in SL58, reptilian, used for ground forces, about 20-30% of Klingon ground troops are Hilladarian.

Home Fleet: Most races have one based at the capital.

Hopkins Theta Code: Used by Orion to contact Federation, Objective Juggernaut.

Hydran Expedition: Hydran attempt to break through to Federation.

IBM-2786: An obsolete commercial computer used within the Federation, *Rescue on Roon*.

Ice Monster: Monster in SM14.

IFF: Identification Friend or Foe, electronic identification system.

Igneous: Monster in SM8.

Imperial Reserve Fleet: A Klingon fleet formation held at Klinshai for use only in the event of a major war.

Imperial War Reserve: A group of Klingon ships kept in active storage for use only in the case of total war.

Internal Security Forces (Klingon): Klingon police, coast guard, tariff and customs service; SL84.

ISF: Klingon Internal Security Forces (i.e., police). While honorable, they are hardly elite and their ships are those too old or small for the DSF to bother with.

J'llk: Small fighting lizards, apparently raised by the Kzintis for sport, *Too Close to the Flame*.

J-class freighter: 20-year-old Federation design used by private traders like Jackson Grimes; *Surprise Reversed*.

Jinbaro: Jindarian "king" who leads a Caravan.

Jindarians: Galactic gypsies who have been in space for at least 100,000 years, using hollow asteroids for starships.

Jindavo: Jindarian "prince" who commands an asteroid ship.

Joint Fleet: A Coalition unit including Lyran, Romulan, and Klingon units.

Juggernaut: Large robot ship from another galaxy; Objective Juggernaut.

K'rragg's disease: A disease affecting Kzintis with an 85%

mortality, and the survivors are unfit for further service, *Too Close to the Flame*.

K1, K2, etc.: Klingon rank system. K1 is an ensign, K6 a captain, K10 a fleet admiral. See article in CL #7.

Kail: Klingon exclamation of determination.

Kareli Design Bureau: Klingon naval architects who designed the D6, D7, and B10.

Kareli-66: The sensor systems installed on D6 and D7 ships.

Karzok wiggler: Unidentified animal, probably herbivorous; *Where Wisdom Fails*.

Kaufman Retrograde: Maneuver in which Federation ships survive against a superior force by moving in reverse and keeping the enemy at bay with photon torpedoes; SG32.

Kdarth: Fearsome beast with many teeth and tusks, standing 3m high at the shoulder, found on a planet near the Klingon-Lyran Neutral Zone, considered a test of Klingon warrior skills to face one with nothing but a knife, considered a delicacy by the Lyrans, *Cold Front*.

KDB1104: Design study for Klingon D5 war cruiser; see R3.23.

KDB1183: Design study for Klingon E5 battle escort; see R3.65.

Keelvosh: A Klingon term indicating garbage or perhaps manure. The complete expression is "deep keelvosh".

Kegth: Hydran game, *Brothers*; SN20.

KGB: Klingon General Bureau, external intelligence service.

KIA: Killed in Action.

King of the Universe: ISC term for God.

Kiriok Redbloom: A plant used as a mind-altering drug, illegal within the Federation, *Rescue on Roon*.

Kiva Roat: A Qnaabian staple, *First and Future Shock*.

Kizra: Small tasty animal that Kzintis believe are found in the afterlife, *Too Close to the Flame*.

Kleptic: Shana's caravan, *Within the Glove*.

Klingon Warrior Colonies: A series of planets inside Klingon space on which colonies were established to breed additional Klingon warriors. Klingons from the home planet (Klinshai) consider themselves socially superior to colonials. Colonial officers have less career potential in the Deep Space Fleet.

Klogen: Something from the mouth of which a Jindarian might imagine hearing the truth, *Within the Glove*.

Korlivilar: One of the ISC races, panther?, lays at position, has claws, purrs; *First and Future Shock*.

Kozenko Design Bureau: Designed D5 war cruiser and E5.

Kozenko-65: The type of sensor system fitted in Klingon D5 war cruisers and most of the WYN fish ships.

Kresian Traliat: Entirely harmless plant used as a spice, *Rescue on Roon*.

Lavaguards: Tholian PF flotilla. Fought Seltorians Y185; SH116.

Littermate: Lyran term for a brother from the same litter.

Long Claws, Battle of: First battle of LDR independence; SH122.

Lower Empires: Organian term for races in SFB universe.

Lyran Democratic Republic: An independent county which broke away from the Lyran Empire in Y145.

M'eershk: Lyran curse, *Too Close to the Flame*.

M'rila: A deployment pattern for guards on a Kzinti BC, *Cold Front*.

Macintosh-XV: An obsolete commercial computer used in Federation space, *Rescue on Roon*.

Marquis's Fleet: Kzinti forces on Federation border.

Marquis: Second highest of the four Kzinti nobles.

Marshal: A Lyran rank of nobility, commanded BCHs.

Masters: Race of powerful beings who amuse themselves by stealing starships and playing SFB for real. See *The First Round*; SL50, SG30, SL107.

Mate-less curs: Kzinti insult, *Too Close to the Flame*.

Maximum Veracity Directorate: Klingon ISF intelligence branch,



frequently referred to as the MVD; SH124.  
 Metamorph: Monster in SM15.  
 Milkbeast: Kzinti insult, Too Close to the Flame.  
 MindBlanks: When the Tholian seeker has drained a life form, the resulting husk is referred to as a mindblank and acts as a primitive defense robot.  
 Mind Lance: A weapon employed by the Shamans of Sentria.  
 Mind Monster: Monster in SM6.  
 MJN: Tri-video "expose" on the conspiracy by Mad Jack Nelson, and just about everyone else, to keep the General War going.  
 Moray Eel of Space: Monster in SM3.  
 Mudbat: A lifeform native to Sebelia IV, attacks when startled.  
 Mulakee: Monster that likes the taste of munitions, first seen in Y163 by Gorns; SL154.  
 Mutiny: Generally assumed to be any uprising against lawful authority, legally the unlawful removal from command of the lawful commander.  
 Neutral Zone: A buffer zone between two hostile forces. Either can operate a limited number of ships, bases, and colonies in the zone.  
 No-Fur-Squad: Appellation assigned to an ad hoc grouping of Kzinti frigates, Too Close to the Flame.  
 North, Fleet of the: Romulan forces on the Gorn border.  
 Northeast Fleet: Klingon formation on the Federation Front in the General War.  
 Northern Fleet: Klingon forces on the Kzinti border.  
 Northern Reserve: Klingon forces backing up the Kzinti and Federation border forces.  
 Northwest Fleet: Klingon formation on the Kzinti Front in the General War.  
 Oblique Attack: Maneuver in which a ship moves to one side of the target allowing it to turn away from the enemy after firing. Used by Klingons to bring waist phasers into arc.  
 Old Colonies: Three Hydran planets never conquered by the Klingons or Lyrans and the basis of the Hydran resurgence in Y135.  
 Old Kings: Previous galactic rulers; R3.1.  
 Olympus Fleet: A Kzinti fleet led by the DN *Olympus*.  
 Operation Cavalry: Alliance attack on Klingon territory; SH11.  
 Operation Cutthroat: Orion trap involving Q-ship in Y167; SH132.  
 Operation Hydra: Unsuccessful Federation attempt to break through to Hydrans during General War.  
 Operation Nutcracker: Klingon-Romulan attempt to destroy Tholians.  
 Operation Remus: Alliance effort to destroy Romulan capital and end the war; was only partly successful as the planet Remus became uninhabitable.  
 Operation Reptilicon: Romulan attack on Gorn cruiser; SL25.  
 Operation Tribune: Romulan attack on Gorns; SL73.  
 Operation Triumph: Romulan plan to invade Gorn system; Refiner's Fire.  
 Operation Unity: Galactic attack on Andromedan base.  
 Order of the Monarch: Hydran decoration awarded by the King for meritorious action in his service. There are three degrees; CL11.  
 Order of the Pyramid: Most common Hydran medal, awarded for doing one's duty. Referred to by enlisted Hydrans as "the officer's good conduct medal"; CL11.  
 Order of the Sword: Unofficial Hydran medal awarded by the guilds; CL11.  
 Order of the Triangle: Hydran decoration for competence and merit while leading other officers in combat; CL11.  
 Organians: Race of super-powerful galactic philosophers; constantly meddle in galactic affairs, in Fed-Klingon neutral zone; SL62, SL63, What Price Victory?

P'sora: A snake that is lethal, found on Kzinti worlds, Too Close to the Flame.  
 Pathfinders: Apparently an elite Klingon team of some sort, mentioned in Volunteers.  
 Patrol Detachment: Romulan forces on the Tholian border.  
 Pelione, Treaty of: Established Fed-Rom Neutral Zone in Y155.  
 Pennington Flash: An emblem worn by Reynolds, who was not to be trusted.  
 Pentarchy: Kzinti five-headed government including the Patriarch and four nobles (Duke, Count, Baron, Marquis).  
 Phtholognyrrh: Hydran ship design agency, designed Gendarme police ship; R9.39.  
 Planet Crusher: Monster in SM1.  
 Plant dung: Kzinti exclamation of surprise, Too Close to the Flame.  
 Plant Eater: Kzinti insult, Too Close to the Flame.  
 Plants: See SL103.  
 Pleiades Turkey Shoot: Klingon fighters attack *Zhukov* carrier group; SH17.  
 Police Gazette: Magazine read by Klingon ISF crews.  
 Porcupine Boys: A group that Chandler owed a debt to.  
 Praetorian Guard: Romulan equivalent to Federation Prime Teams.  
 Praetorian Preditrate: A secret Committee which selects individuals from the State Security Administration and the Military to be inducted into the Praetorian Guard.  
 Prellarian Null Grav Ball: Apparently a variation of handball.  
 Prime Directive: A Federation code of non-interference with developing cultures. Also SFB Role-Playing Game.  
 Prime Team: A top Federation action team, combining the aspects of a commando team, a diplomatic mission, and scientific research team.  
 Proconsul: Romulan theater commander, rank.  
 Project Ghost Watch: A Secret Federation project to find a way to track cloaked ships, Y164.  
 Pronhoulite: One of the ISC races; devoted to religion, duty, and friendship; has a periodic "time of cleansing" when they eat "tribal rations"; First and Future Shock.  
 Protection Launched Overhead: Leebyahhn military forces commanded by Yessir Imarat; SH12.  
 Qnaabian: One of the ISC races, has a tail and breathes air laced with chlorine; First and Future Shock.  
 R-types: Class of old Federation heavy cruisers, including *Republic* and *Reshadije*.  
 Rama'cha: Romulan house that gained power after Operation Remus, tried to negotiate a peace treaty in Y182, Betrayal.  
 Rapid Transportation Network: Andromedan system of bases linked by navigational beacons and used for high-speed travel by Andromedan ships.  
 Raver's Weekly: Klingon magazine read by PF crews.  
 Red Claw: Lyran Duchy on Kzinti border.  
 Red Fleet: Klingon fleet on Federation Border; Commanded by Kumerian; defeated in Operation Cavalry.  
 Red Machine, The: Federation Prime Team.  
 Red Wyn Express: Orion convoy to WYNs; T6.0.  
 Reserve Fleet: Most races had a fleet of this designation during the General War.  
 Retrograde: Maneuver in reverse; see Kaufman Retrograde.  
 Richardson Climber Vine: A form of vegetation found usually in symbiotic relationship with 'Tret Magnofolias on Sebelia IV.  
 Rigellian: Federation member race, dark skin with blue pattern.  
 Rockheads: Derogatory Klingon term for Tholians; SL64.  
 Rovillian: One of the ISC races, amphibious, has their own flippers; First and Future Shock.  
 S'kree: A term analogous to soul used on Sentria.  
 Salvager: Term for a Jindarian Prime Team.  
 Seeker: Name assigned to a Tholian Exploration probe.



Signature, electronic: The pattern of electronic signals, emissions, and echoes from a given target used in identifying it.

Skoleans: Mercenary pilots for Gorns.

Slirdarians: Klingon subject race, mentioned in SL58, cross between ape and bear, used for ground forces forming 50% or more of any given unit. A few Slirdarians hold marine commissions. Kobol was a Slirdarian.

Smarba, Treaty of: Klingon-Romulan technology transfer agreement signed in Y159.

Southeast Fleet: Klingon formation on the Federation Front in the General War.

Southern Reserve: Klingon forces backing up the Hydran and Federation border forces.

Southwest Fleet: Klingon formation on the Hydran Front in the General War.

Space Amoeba: Monster in SM2.

Space Dragon: Monster in SM7.

Star Fleet: Proper name of Federation navy.

Starswarm: Monster in SM12. Von Neumann machines.

Storm Winds: Kzinti fighter squadron on *Typhoon*.

Suez: Orion Daven Cartel base in Lyran space in Y182. The Long Road Home.

Sunsnake: Monster in SM5.

Tahm'Shree: Name of a shuttle used by Mizari'Jhot to flee from Romulan pursuit, Y164.

Task Force Kosnett: A Federation unit during the General War.

Task Force Stocker: A Federation unit during the General War.

Templars, The: Federation Prime Team that uncovered a plot by the Governor of New Marseilles to hide the existence of a primitive sentient race in Y187, assigned to CC *Excalibur*.

Tholian Border Squadron: Another name for the Romulan forces on the Tholian border.

Tholian Frontier Squadron: Sometimes called Tholian Border Squadron or Harassment squadron; Klingon unit on Tholian border. Constantly fighting Tholians in numerous border incidents designed to show the Tholians that the Klingons still claim their territory. Used for extensive combat training. Considered the premier assignment for a senior captain. Once commanded by Kumerian, later by Korath, and during the war by Kurlak.

Tholian Home Galaxy: The original home galaxy of the Tholians, from which they were ejected about 100 years before Y0.

Tholian Will: The rule of the Tholians over their original home galaxy.

Timber Wolves, The: Federation Prime Team.

Titan Fleet: A Kzinti fleet led by the DN Titan.

Tollindium: High energy mineral which interferes with sensor scans; Refiner's Fire.

Trade Wars: Mentioned in Volunteers.

Trafkh: Kzinti curse, Too Close to the Flame.

Tret Magnofolia: A form of vegetation found usually in symbiotic relationship with Richardson Climber Vines on Sebelia IV.

Triumvirate: Romulan supreme military council, Refiner's Fire.

Tufts: Sometimes Ear Tufts, Lyran intelligence.

Turkey Shoot: Pleiades Turkey Shoot; SH17.

Ulevian Anequid: Mentioned in The First Round.

Vampire: A term used to announce that incoming drones have been detected. The Long Road Home.

Vandha: Second battle of LDR independence; SN18/SH123; see R14.

Vanguard Teams: Gorn Equivalent to Federation Prime Teams.

Vastag: ISC term for items of no consequence, similar to "Baloney" only stronger, First and Future Shock.

Veldte: Kzinti heaven, Too Close to the Flame.

Vengeance Fleet: Gorn Fleet formed for a special attack mission in Y177.

Veskus, Spirit of: This refers to an ability of Sentrians to create a desert sandstorm through an act of will.

Vudar: A subject race in the Klingon empire.

Vulcans: Federation member race, second in importance only to the humans. Famous for their intellects, lack of humor, and pointed ears.

West, Fleet of the: Romulan forces on the Federation border.

Western Fleet: Klingon forces on the Hydran border.

Whiskers: Kzinti Intelligence service.

White Elephants: Kzinti 23rd Fi-Con division; SH14, SH32. The term comes from human history, but the Kzintis were so taken with the story that the unit adopted that name.

White Tigers, The: Federation Prime Team that entered service directly from its graduation after acing the test and setting records while doing so.

Wolfpack: Orion raiding group; SN5.

Wraiths, The: The first Primary Contact Team formed, rumored to have been made up of individuals that General Kripney saved from courts-martial and other disciplinary actions.

Wuggers: A half monkey half spider life form native to Sebelia IV, prone to stealing pretty items.

WYN War of Return: Y186, also known as the Second Kzinti Civil War. The attempt by the Usurper and his forces in the WYN Cluster to return to power in the Hegemony.

Y'li: Brew drunk by Kzintis, Too Close to the Flame.

Zarmoly: Unidentified animal, probably carnivorous, Where Wisdom Fails.

Zegurnii Design Bureau: Designed Klingon fighters.

Zoolies: Klingon subject race, mentioned in SL58; have large eyes and incredible night vision; used as scouts by Klingon landing forces.

## INDEX OF NUMBERED MILITARY UNITS

Named military units are under Miscellaneous.

1st Fleet: Tholian forces on Klingon border.

1st Fleet: Unused title for Federation Home Fleet.

1st Imperial Legion: Romulan X-ship unit Y186; T10S2.

2, CVG #2: *Zhukov* carrier group Y175; SH81.

2, VW-2: Federation Fighter Wing 2, assigned to *Zhukov*.

2nd Fleet: Federation Exploration Command.

2nd Fleet: Gorn forces on Federation border.

2nd Fleet: Tholian forces on Federation border.

2nd Imperial Legion: Rolandus' non-X squadron Y186; T10S2.

2nd Star Legion: Romulan forces in Operation Tribune; SL73; divided into 1st through 6th "Cohorts."

3rd Battle Squadron: Federation X-ship squadron fighting Andromedans in Y207 in an alternative timeline; SH166.

3rd Drone Bombardment Group: Kzinti unit ambushed by Klingons in Y161; SH54; two of the three ships were destroyed.

3rd Field Force: Kzinti unit; SH5.

3rd Fleet: Federation forces on Klingon border.

3rd Fleet: Federation; SL71.

3rd Fleet: Gorn; SL102.

3rd Fleet: Tholian forces on Romulan border.

3rd Frigate Squadron: Klingon part of Tholian Border Squadron; SL64.

3rd Star Legion: Romulan forces in SL74, mentioned N10 story.

3.1, TG3.1: Task Group 3.1, built around DN *Konkordium*; SH81; Y175.

4, Federation battlestation K4: Klingon border, destroyed in SH49; apparently rebuilt as it is mentioned in SN12.

4, Romulan Starbase IV: third battlegroup, squadron III-C, Report by Tiercellus.

4th Fleet: Federation forces on Kzinti border.

4th Star Legion: Romulan fleet mentioned in N10 story.



- 5, Federation Starbase #5: near Klingon border, SN13; mentioned in First Command.
- 5, Kzinti Battle Station #5: site of major battle; SL86.
- 5th Fleet: Federation forces on Gorn border.
- 5th Fleet: Gorn Fleet formed late in the war for duty on the Romulan frontier.
- 5th Patrol Squadron: Romulan Decurion Interceptors, attacked Federation colony planet Y179 SH33; pursued and virtually annihilated by Federation forces; SH34.
- 6, Klingon Border Station #6: Klingon base on Federation border, near K4; A Warrior's Death; SN16.
- 6, Klingon Starbase #6: Northern Fleet headquarters.
- 6th Fleet: Federation force on Romulan border, commanded in Y173 by Admiral Matthews, divided into three divisions commanded by Stocker, Williams, and Yefimov.
- 6th Fleet: Gorn forces on Romulan border.
- 6th Patrol Squadron: Romulan Decurion Interceptors, attacked Federation colony planet Y179; SH33; pursued and virtually annihilated by Federation forces; SH34.
- 7, Fighter Wing #7: Fighter wing of the tug *Wolf* while carrying a CVA and CVL pods in Y184; SH102.
- 7th Fleet: Federation forces on Tholian border.
- 7th Fleet: Gorn fleet formed late in General War for war against the Romulans.
- 8, Federation Starbase #8: Day of the Eagle.
- 9, Battlestation #9: Federation base on Romulan border, destroyed during Romulan invasion, Day of the Eagle.
- 9, Federation Border Station 9: Federation base on Klingon border, mention in Patrol.
- 9th Assault Fighter Squadron: Klingon Z-1 unit at Turkey Shoot.
- 10 Akk-10: Tholian base near Federation border, A Sense of Obligation; SL148.
- 10, Starbase #10: Federation base between UFP center and the Romulan border. Rear headquarters for Sixth Fleet.
- 11, Battlestation #11: Federation base in rear of Sixth Fleet area, Nimitz group was based there, Day of the Eagle.
- 12, Ajax 12: Federation convoy escorted by *Republic*.
- 12, Base 12: Named as base that *Golden Crown* would retire to, Too Close to the Flame.
- 12, Starbase #12: Federation HQ for Sixth Fleet, Romulan border. Location where a Prime Team in training transferred from the tug *Copernicus* to the CL *Suffolk* in Y164.
- 12, VF-12: Squadron of Federation F-4 fighters on *Nimitz* in SH96, Y172.
- 12th Flotilla: Kzinti PF unit; SL77.
- 13, Border Station 13: Klingon base on Hydran border destroyed in SH42, rebuilt and then destroyed again in Where Wisdom Fails.
- 15, Federation Starbase 15: Near Klingon border, surrounded and cut-off during Klingon invasion; F&E.
- 16, System Station 16: Lyran station in Silver Moon County manned in Y182 by relatives of the ousted family from Predator County. The Long Road Home.
- 16th Cohort: Romulan unit attacked by Stocker, Surprise Reversed.
- 17th Battle Group: Kzinti unit, served in Romulan territory; SL74.
- 18, Klingon Border Station #18: Tholian border. The *Vandal* came here after escaping from the Holdfast.Y149.
- 19, Klingon Border Station #19: Kzinti border, Frontier Patrol.
- 19th Flotilla: Kzinti PF unit; SL74.
- 20, VF-20: Squadron of Federation F-15 fighters on *Nelson*, Known as the *Blackadders*, Y174; SH70.
- 20th Flotilla: Kzinti PF unit; SL74.
- 23rd Fi-Con Division: Kzinti PF/Fighter unit; SH14, destroyed in combat Y185 SH32. Included the 23rd and 24th Flotillas and the 210th and 211th Fighter Squadrons.
- 23rd Flotilla: Kzinti PF unit; SH 14, SH32.

- 24th Flotilla: Kzinti PF unit; SH14, SH32.
- 26, Attack Shuttle Group #26: Kzinti unit in SH5.
- 26, Federation Battlestation #26: On Romulan border, Day of the Eagle.
- 42, VF-42: Squadron of Federation F-14 fighters in SH9.
- 43rd Fighter Squadron: Klingon Z-2 unit on F5V *Dragon Carrier* fought Federation and Orions Y172; SH61.
- 48, VF-48: Squadron of Federation F-4 fighters on *Langley* in Y172, fought Klingons and Orions; SH61.
- 55, VF-55: F-14 squadron on *Zhukov*, part of VW-2.
- 55th Fighter Squadron: Klingon Z-V unit at the Turkey Shoot.
- 66, VT-66: A-10 squadron on *Zhukov*, part of VW-2.
- 71, VF-71: Squadron of F-18Cs operating from a carrier pod from the tug *Wolf* in Y184; SH102.
- 72, VF-72: Squadron of F-18Cs operating from a carrier pod from the tug *Wolf* in Y184; SH102.
- 73, VF-73: Squadron of F-14Bs operating from a carrier pod from the tug *Wolf* in Y184; SH102.
- 73rd Fighter Squadron: Kzinti AAS fighter squadron *Storm Winds* on *Typhoon*.
- 75th Assault Fighter Squadron: Klingon Z-D unit at Pleiades Turkey Shoot.
- 77th Gunboat Division, *Mighty Marauders*: Group of 4 Klingon PF flotillas; SH29. Only unit able to bring four PF flotillas into a single battle. Covered by a special rule in F&E.
- 79th Gunboat Division: Klingon PF unit at Turkey Shoot.
- 83rd Fighter Training Squadron: Klingon Z-2 unit at the Turkey Shoot.
- 85, VF-85B: Fighter squadron on *Moskva*, fought at Turkey Shoot in Y184; SH17.
- 94th Fighter Intercept Squadron: Federation National Guard F-4 squadron, fought Romulans Y179; SH33.
- 98th Fighter Intercept Squadron: Federation National Guard F-4 squadron, fought Romulans Y179; SH33.
- 111th Fighter Squadron: Klingon Z-Y unit at the Turkey Shoot.
- 149th Fighter Squadron: Klingon Z-Y unit at the Turkey Shoot.
- 171st: Needle Flotilla in Y183; SL153.
- 191st: Designation of a Federation scout unit. Prime Directive.
- 210th Fighter Squadron: Kzinti unit (carried by PFs); SH32.
- 211th Fighter Squadron: Klingon Z-V unit at the Turkey Shoot.
- 211th Fighter Squadron: Kzinti unit (carried by PFs); SH32.
- 289th Fighter Squadron: Klingon Z-V unit at the Turkey Shoot.
- 299th Fighter Squadron: Kzinti fighter unit in SL74.
- 312th Assault Fighter Training Squadron: Klingon Z-1 unit at Turkey Shoot.
- 312th Battle Squadron: Neo-Tholian force; SH22. See R7.60.
- 317th Ground Division: Klingon ground unit; SL58.
- 700th Gunboat Flotilla: Klingon DSF, first PF unit formed.
- 701st Gunboat Flotilla, Bounty Hunters: Commanded by Kollos Kumerian; Klingon PF unit in SH14 and SL2. This was an ISF unit and one of the first two PF flotillas formed. Destroyed in Y183; SH153.
- 714th Gunboat Flotilla: Klingon PF unit in SH9.
- 751st Gunboat Flotilla, *Raiders*: Klingon PF unit on *Raider's Roost*. Attacked ISC mobile base in Y188; SH25.
- 771st Gunboat Flotilla, *Maimers*: Klingon PF unit in SH29, part of 77th.
- 772nd Gunboat Flotilla, *Manglers*: Klingon PF unit in SH29, part of 77th.
- 773rd Gunboat Flotilla, *Murderers*: Klingon PF unit in SH29, part of 77th.
- 774th Gunboat Flotilla, *Maniacs*: Klingon PF unit in SH29, part of 77th.
- 791st Gunboat Flotilla: Klingon PF unit at Turkey Shoot.
- 792nd Gunboat Flotilla: Klingon PF unit at Turkey Shoot.
- 793rd Gunboat Flotilla: Klingon PF unit at Turkey Shoot.
- 914th Base Force: Romulan unit in SL74.



# IN THIS EMPIRE

Jeff Laikind

At GenCon, the two Steves told me to "take charge (of F&E) and move out" and I took them seriously! We are looking for good F&E material to publish and welcome your input. We need scenarios, strategy articles, and variants! ☺☺☺

# SUBSTITUTIONS

Steve Cole

In this issue of Captain's Log, we are happy to bring you the "F&E Substitutions Available by Date" chart on the inside back cover. It was suggested by Scott Stanford, and we take such suggestions seriously! ☺☺☺

## FEDERATION & ENQUIRE

### THE LYRAN SCOUTS

**Q1601F:** Can I build Lyran CWS scouts whenever I want to, even though the SFB Master Ship Chart says they were not built until Y172?

**A:** Yes, you can. Carrier War replaced all of the F&E production annexes, and many restrictions on "obvious variants" were eliminated to give the players more control over their force mix. The historical Lyrans did not build CWSs until later because of their need for CW hulls. If you are willing to give up the combat power to get the EW, then that's an appropriate decision for you to make as Lyran commander.

### WHEN WILL MY SHIPYARD COME IN?

**Q1602F:** When does a new shipyard come on line? The Kzintis were kicked off of the map on Turn #4 and want to know if they can begin using the off-map shipyard on Turn #9 or if they have to wait until Turn #10?

**A:** Since they paid for the shipyard over six turns (#4, #5, #6, #7, #8, and #9), it wasn't finished until the end of their Turn #9 and cannot produce ships until Turn #10.

### THE UNWELCOME BASE

**Q1603F:** Could a base be built in the hex of an unsupplied, fighterless base (or planet without a PDU), but not in the same "system"?

**A:** Rule (433.411) says it can if the original base is friendly. The only way for this to happen is when a base in enemy territory is cut off from the owner's supply grid.

### GARRISONING THE PLANETS

**Q1604F:** What happens if you capture a capital hex, but do not possess the units necessary to fully garrison it?

**A:** You own whatever planets you want to garrison (508.23), and the rest revert to the original owner as a partial supply grid (413.4).

**Q1605F:** Do two crippled ships count as one ship to garrison a planet? How about ship equivalents of PFs and/or fighters (assuming that one left a carrier group or PFT as part of a capital garrison)?

**A:** Rule (508.23) says "one ship or PDU per planet". It doesn't say "ship equivalent". So one crippled ship can garrison one planet, but a "ship equivalent" of fighters/PFs cannot.

### A NEED FOR COMMANDO SHIPS

**Q1606F:** The Hydrans, Lyrans, and Kzintis have no commando ships before Y160, but other races do. Will this lack be addressed in Advanced Operations?

**A:** I totally agree with the need for such ships and have discussed it with the Steves who have agreed to add the needed ships to SFB. It's not clear at the moment if the ships will be in Advanced Operations, but if they are needed, they will be there! Count on it.

### JUST WHAT IS THE SPARROWHAWK?

**Q1607F:** Rule (421.21) states that the Romulan SPH counts as a CW for moving an FRD. However, rules (516.14), (516.21 F), and (516.33) seem to contradict this, implying that an SPH is a tug and can move an FRD by itself.

**A:** The SparrowHawk is an odd duck in the Star Fleet Universe. It is a war cruiser, and it isn't, depending on the specific case involved. This oddness carries over to the LTT variant of the SP, which is an LTT in some ways and a TUG in others, and neither one in some cases. In this case, a specific rule (421.21) is provided and overrules any implications of tugness found elsewhere. The cost of the modularity of the SparrowHawk design is that some things are just strange. After all, if an SPH could tow an FRD, could any SP? LTTs are specially modified to tow FRDs, but this reinforced structure isn't possible for the modularized SPH. ☺☺☺

## ALLIANCE MAULERS

FED	KZINTI	GORN	THOL	HYD	ORION	ISC
CAM + 10	BCM + 10	MCM + 10	CAM + 10	CAM +1 10	There isn't one!	CAM + 10
CAM ■■■■ 4	BCM ■■■■ 4	MCM ■■■■ 5	CAM ■■■■ 4	CAM ■■■■ 4	There isn't one!	CAM ■■■■ 5
SL91	CL16	CL16	SFT#2	CL16	Never!	SFT#2
MCL + 7	MCM + 7	MHD + 7	MCW + 7	MCL + 7	MBR + 7	MCL + 7
MCL ■■■■ 4	MCM ■■■■ 4	MHD ■■■■ 4	MCW ■■■■ 4	MCL ■■■■ 4	MBR ■■■■ 4	MCL ■■■■ 4
CL16	SSN4	SSN4	SSN4	SSN4	CL17	CL17

The chart shows the F&E values for the conjectural alliance and neutral maulers. The place where each has been (or will be) published is given. The ISC and Tholian CAMs will be in Star Fleet Times, but the specific issue is not known. Each race can produce one CA-mauler in the Spring and one CW-mauler in the Fall of each year. There is no large Orion mauler, so they cannot have a Spring build. CW conversion costs 4; CA conversion costs 5. Substitutions are allowed.

Note that the use of Alliance maulers is NOT a part of the regular game but an optional variant agreed to by both sides. Alternatively, players could use SFB rule (U7.12) as the basis for handling captured mauler technology in their own campaigns and scenarios. ☺☺☺



## TACTICAL NOTES

Tactical notes are the Federation & Empire equivalent of SFB term papers. Players should use the same procedure for submitting tactical notes. The ranks listed below are the same as term papers; players have a single rank and can earn promotions by term papers, tactical notes, or for short articles in various sections. One "Best of the issue" award, counting as two papers for promotion, is granted for F&E in each issue.

### KZINTI DEFENSES

— *Lieutenant JG Matthew K. Hargraves, USS Michigan*

The Kzintis must do the following to survive until Turn #8 (at which point they can be saved by the Federation).

1. Do not waste economic points on bases (buying mobile bases or upgrading existing bases). These are targets that are easy to kill, and you may just lose them before you see a return (or the Coalition will kill your mobile base on their turn after you sink 15 economic points into it to make it a battlestation, but it still has the factors of a mobile base).

2. Build CVs and escorts. These are your lifeline. If you do not have these, you do not have a chance.

3. Build four PDUs every turn at the capital planet. Spend every last economic point upgrading a major planet elsewhere in the capital.

4. Do not kill your own ships. They are more important than your shipyard, as you could kill 60 Coalition ships, cripple 50 more, and he will be back for more. If you kill 20 of your own and cripple 25 more, you will not be there when he comes back for more. If it comes down to it, lose the capital, repair your ships off map (you should have sent your Home Fleet FRD off map on Turn #1), and relocate to the Marquis' starbase. The Coalition will be hard pressed to take that, and start a Federation assault, and you might be able to take your capital back for good (still build an unassailable shipyard off map) on Turn #8, if you save your ships and hurt him bad enough.

As a parting note: If the Coalition is using a standard Molasses Attack, the Tactics of Admiral Alan Gopin (build bases in the capital) are very solid. But if you see the Northern Reserve Fleet in its entirety set up 6 hexes away from Kzintai, and then new builds move to within 6 hexes of Kzintai, you need to build PDUs (they're faster) so that 50 to 60 Coalition ships in the capital on Turn #2 will not scare you too much.

*Rated the Best Tactical Note in this issue.*

### SALVAGE PLANNING — *Cadet Joe Abrisz, USS Idaho*

Utilize Salvage (439.0) to maximize potential economic efficiencies. Prepare plans for your next several turns of production. Prioritize within your planning budget all the items you want to be able to produce. Those items that are a "must" will demand that you generate sufficient income to produce them.

Resolve combat damage by carefully choosing when and where to give up less valuable ships for salvage income as a means to guarantee your upcoming economic needs. This principle of "resale" may provide the last few economic points for a hard-pressed race to convert a starbase, produce an FRD, make a mobile base, etc., as well as complete a full production schedule of the newer, more powerful ships.

Plan ahead! Be pro-active and think creatively. Do not be compromised into disaster by overcrowded repair facilities, empty pursuit battle losses, and diminished returns from unfilled production possibilities due to income shortfall. Although ship preservation can be a religion, there will be those times when hulls must be sacrificed for the benefit of your racial security.

### DOUBLE DUTCH THRUST

— *Senior Lieutenant Stewart Frazier, USS Ohio*

Mercer's "Priorities" (Captain's Log #14) has a minor drawback in that he does not think the Federation will be able to defend against this thrust by counterattacking. As the Fleet is within 6 hexes of the Federation capital, that places three Federation fleets within range, depending on the route (Home Fleet plus production, Third Fleet and/or Fourth Fleet). Even if the Federation is "unsuccessful" in causing the Klingons to retreat to a point more than 6 hexes away from the capital, the Federation could elect to disrupt the supply route(s) by attacking (blockading) the border guards! By "ignoring" the Klingon Fleet and blocking the supply point, the Klingon Fleet is limited in movement (keeping it well outside the capital) and firepower.

The Double Thrust, which seems to have many of the same problems, places two fleets (each about double the initial Klingon East Fleet in size) into different sections of Federation space. For the best results, some forces from both the Kzinti and Hydran fronts should be reassigned to the East Fleet deployment area for additional firepower. The East Fleet should initially start mainly in hex 1812 to prevent a Hydran expedition and then move to 2215/2416. The East Fleet is bolstered by Turn #5 production and forces from the Kzinti front on Turn #6. The forces from the Hydran front are moved to 1809 or 1807 via Operational Movement on Turns #5 and #6 and are joined by the Turn #6 production.

Turn #7 production and the first Imperial War Reserve squadron open the Federation border at 2008 and should take the planet at 1910, allowing the force built around the Turn #6 production and the units drawn from the Hydran front to strike northward to either 2406, 2306, or 2407 to support the southern thrust at 2712. The remainder of the East Fleet at 1813 plus the forces drawn from the Kzinti front has the BATS at 2414. The Turn #5 production heads for 2712 with an E4/E4A headed for the Orion province. Do not forget to pair some E4/F5s for province raiding and neutral zone sweeping! The Kzinti front forces should be able to clean out the Marquis area as the Federation Fourth Fleet should be busy inside Federation space.

Now the Federation has two thrusts coming in and should be hard pressed to defend against both. The northern thrust is within reach of all three of his fleets and can strike at his planets (Theodore Fay's "Strike North" in Captain's Log #14) or the Federation capital and has the better protected supply line. If a serious counterattack is mounted, the southern thrust should have "clear" sailing into the Federation capital. The southern thrust has already taken the Orions out but is in a weaker position; however, if hit hard enough to force it back to the Empire, the northern thrust is clear to wreak havoc on the Federation capital and those northern planets with the Imperial War Reserve! Best of all, this strategy does not interfere (much) with any other early war strategy! There is an argument that the Klingons should delay their initial attack until Turn #8 to allow the Federation Fourth Fleet to support the Kzintis and then attack while it is out of position, but this course should only be pursued if the Kzintis cannot mount an offensive thrust of their own to aid the Federation Fourth Fleet.

### BETTER USES FOR DRONE PODS

— *Rear Admiral Jeff Laikind, USS Wisconsin*

The Klingon drone bombardment pods should not be used for drone bombardment! Instead, put them on a TGA and directly into the battle force, sitting in the formation bonus position. When attached to a TGA, they provide a 12-attack-factor ship with 2 points of electronic warfare (drone ships do not lose combat value when they use electronic warfare points) that will take 39 points of directed damage to cripple.



## WEIGHT THE ATTACK

— *Ensign Joe Stevenson, USS New Jersey*

When attacking any undefended base, use the minimum necessary fleet. This way, you can attack as many targets as possible. This is especially important for the Coalition, who must use their numerical superiority to overwhelm the Alliance.

These calculations are based on choosing a BIR of two, with no modifier and the attacker having a -1 shift due to EW. The Attacker's average Combat Coefficient is .2 (actually .183, but there is no .183 on the chart). The Defender's Average Combat Coefficient is .225 (actually .2, but let us be pessimistic). For a BATS the magic number is 32.

Example: Klingon versus BATS; Battle force; 1x D5, 1x F5Q, 1x F5, 1x E4.

Round #1: Attacker has a ComPot of 32, while the BATS has a ComPot of 18 (12/6). The Attacker does 6 damage points, while the BATS does 4 damage points. The Attacker cripples the E4, while the BATS loses its 6 fighter factors. The crippled E4 will be left out of the next battle force.

Round #2: Attacker's ComPot is now 28, while the BATS ComPot is 12 (12/0). The Attacker again does 6 damage points, while the BATS does 3 damage points. The Attacker cripples the single F5 leaving 2 minus points, while the BATS is crippled with 6 minus points remaining. The crippled F5 will be left out of the next battle force along with the crippled E4.

Round #3: The Attacker's ComPot is now 23, while the BATS ComPot is 6 (6/0). The Attacker does only 5 damage points, while the BATS does only 1 damage point. The Attacker loses 1 of his minus points, while the base loses 5 of its 6 "minus" damage points. Both will have 1 minus point in the next, and final, round. The crippled E4 and F5 will again remain out of the battle.

Round #4: The Attacker's ComPot is still 23, and the BATS ComPot is still 6 (6/0). The Attacker again does only 5 damage points, while the BATS will again score only a single damage point. The Attacker loses his last minus point, but the BATS, after accounting for its 1 remaining minus point, must resolve 4 damage points against itself and is destroyed since 4 is more than half of 6. The battle is now over.

In four rounds, the Attacker kills the BATS with two crippled frigates as casualties. Using the same iteration will show that 43-48 points will result in one crippled ship. Note that an escort carrier will reduce the damage taken by one cripple in each case. This calculation works equally well when attacking a minor planet with one planetary defense regiment.

The problem with sending only enough to do the job is that the enemy might have a reserve, or a reaction force that can get there, so weigh that in the balance, or make sure that you have them all pinned.

## DRONE SQUADRONS

— *Lieutenant (JG) Shawn McKee, USS New York*

The Klingon D6D is a very good ship, but to be most effective, it should be operated in squadrons of three. In a major battle, a drone squadron firing in support is equivalent to having an extra dreadnought in the battle force. Better yet, you have the option of placing the drone squadron directly in the battle force. In this role, each drone cruiser has the firepower of a war cruiser, absorbs damage as a heavy cruiser, and produces more electronic warfare points than most scouts. A battle force that includes a drone squadron (in place of the war cruisers), with a D6S in the free scout position, will generate 10 electronic warfare points. No enemy fleet can overcome this advantage and will be forced to either fight with a -2 modifier, or start putting scouts in the battle line. The Kzintis may try to counter with their drone cruisers, but there simply are not enough of them. Also their heavy scouts are inferior.

## PROTECTING IMPORTANT SHIPS FROM PURSUIT

— *Ensign Bill Grace, USS New Jersey*

If you are planning to retreat and need to protect very important crippled units from pursuit, carefully consider how to score damage done against you the round before you leave. If you have fighters or PFs in the battle force, score all but one damage point while leaving at least one attrition unit. Then cripple as large a unit as you can spare. The excess damage points will carry over as minus points, and (308.24) specifically states that minus points carry over into a pursuit round. Then your enemy will have to deduct some damage scored during the pursuit round before his directed damage can be considered. Note that this can be done without having small units in the battle force, but since (302.61) states that damage equal to half of the lowest defense factor is to be ignored, you will have to cripple the last unit with more than one damage point unresolved. This works best for the Coalition, which does not have to deal with enemy maulers.

## KZINTIS: CONVERT THOSE BCs TO CVLs

— *Cadet Mark Morgan, USS America*

If you have Carrier War, you can convert any BC to a CVL at any starbase, though it will not have escorts. This is not a bad thing, as these CVLs can hang around the rear of a battle providing fighters to the full carrier groups in the battle line.

MOBILE BATS — *Cadet David Slatter, HMS England*

Do not bother building battle stations! Two mobile bases cost 5 economic points less, have only 2 less firepower, are quicker to set up (tugs allowing), can be moved later, and are harder to destroy. Do you really need those 4 repair points, or the reaction capability of the fighters? No! Your FRD does the repairs, and the fighter reaction capability is rarely used anyway. The fighters of a battle station are generally used only once, as the base is normally destroyed the first time it is attacked. Only convert mobile bases to battle stations if you intend to later upgrade the battle station to a starbase. Even if you do want to use your free fighters on the battle station conversion, it is still probably better opting for the extra mobile base.

To rub in a point, I have to add the following for the Alliance side if the Special Attack Forces rule is used. It might now be quite correct, but it is a close decision between starbases and mobile bases. Do not bother building starbases; five mobile bases and a fleet repair dock are cheaper and harder to destroy (takes longer).

## GORN CM OVERPRODUCTION

— *Cadet Anthony Paulina, USS New Jersey*

Here is an interesting Gorn tactic. If you overbuild two CMs in addition to the one allowed on the standard build, it will only cost 30 EPs for three 10-point ships! Of course, you still have the allowed HD to CM conversion for only 3 EPs, thus giving you four 10-point ships for 38 EPs!

## ENCORE PAPER: GIVE THE KLINGONS THE LOOT

— *Lieutenant (JG) Matthew K. Hargraves, USS Michigan*

When capturing territory, transfer as much of it as you can over to the Klingons. The Lyrans can always (unless exhausted or overbuilding lots of ships) build their maximum ships and pay their repair bills, but the Klingons commonly have a problem here. Allowing them to capture all possible territory, including any capital hexes, puts them in the economic league of the Federation, with almost identical production and more ships to start with.

They could swing the pendulum around to where the Federation's economy is the one that collapses (under the strain of too many Klingon ships), not the Klingons. ☉☉☉



## SCENARIO (691.0) FEDERATION WARLORDS

*Stephen V Cole and Steven P Petrick*

There is a type of game (both in science-fiction gaming, e.g., Star Fleet Warlord, and in historical gaming, e.g., Viceroy) which can be described as "buy a ship, find a planet, buy another ship, find two planets, buy two more ships, find four more planets, buy eight more ships, find the enemy . . ."

This is a valid genre and is the basis for an interesting new scenario in F&E, one where every race gets "a fair shot" at grabbing for the stars.

### (691.1) GENERAL SET UP

Use the standard F&E map, counters, and rules with the following exceptions:

**(691.11) PLAYERS:** There can be any number of players from 2-6. All players roll two dice and are ranged in order of these die rolls from highest to lowest. In the case of a tie, re-roll to break the tie but the players involved in the tie remain in their original positions relative to other players.

**(691.12) RACES:** Starting with the highest ranked player, each player selects one race and immediately takes control of its capital hex (or hexes).

**(691.121)** Each player controls only the capital and has no ships, provinces, or planets under his control except the planets in the capital hex. Exceptions: See (691.123).

**(691.122)** There are no historical alliances; players make new alliances by (652.1).

**(691.123)** All capitals are the same, and include:

- Home system, two major planets, starbase.
- Secondary system, one major planet, one minor planet, BATS.
- Third system, one major planet, BATS.
- Fourth system, one minor planet, BATS.

Each of these planets begins with one defense battalion, except the Home system which includes one defense brigade.

In the case of the Romulans, the Home and Fourth system are in 4614 while the Second and Third systems are in 4514. The Romulans control the capital province as well as the planets.

In the case of the Gorns, the Home system is in 4402, the second system in 4403, and the third and fourth systems are in 4503. The Gorns control the capital province as well as the planets.

**(691.13) MAP:** There are several major changes to the map:

**(691.131)** The off-map areas do not exist and are not used.

**(691.132)** Neutral areas (e.g., WYN, LDR) can be conquered like any other area (or used as capitals if more players want to participate). The ISC is available for use as a player race if the players have counters (or make their own) or can be conquered by the Gorns and Romulans (or anyone else who can get there). The Orions may be used as a player race with a capital at 2812.

**(691.133)** None of the bases printed on the map exist.

**(691.134)** All territory (except the capital hexes) is unoccupied. No "race" is prevented from capturing unoccupied territory that is (by the borders on the map) nominally the territory of someone else. No "race" is required to conquer all of its own territory before expanding onward.

### (691.2) COURSE OF PLAY

**(691.21) SEQUENCE OF PLAY:** Play proceeds in game turns, each consisting of one Player Turn for each player, from the lowest to the highest ranked player. Each player, in turn, follows the normal Sequence of Play. In general, this includes:

1. Determine how many EPs you have (which on the first turn will be 26 for everyone, except the Gorns and Romulans who will have 2 more points because they hold a province).

2. Produce ships according to the normal rules and the production schedule in (691.22), including any conversions.

3. Move your ships out to capture (and eventually, to defend) as much territory as possible.

### (691.22) CAPTURING TERRITORY

**(691.221)** All territory and planets except the original capital hexes (and the Gorn and Romulan capital provinces) are originally unoccupied and, when captured, are always treated as captured "enemy" territory regardless of the printed borders.

**(691.222)** Planets are captured when you build a defense battalion on them or a base in their hex. Should this base or defense unit be destroyed (and assuming no other base or defense battalion is there to take over), the planet immediately reverts to being unoccupied and neutral.

**(691.223)** Provinces are captured as per (430) and (438). Unoccupied provinces are captured by entering any hex of the province. Provinces already captured by someone else are disrupted by sending a ship into the province or captured when all enemy forces are driven out of the province. It is not necessary to garrison captured provinces.

### (691.23) PRODUCTION SCHEDULES

All races have an "equal" production track as follows:

Spring: 1xDN, 1xCC, 3xCA, 3xCW, 3xDD/DW, 6xFF, 1xTug, 1xLAV, 1xMB.

Fall: 1xCV(757.7-medium, Lyran CV), 1xCC, 3xCA, 3xCW, 3xDD/DW, 6xFF, 1xTug, 1x SAV, 1xFRD.

All substitution and conversion rules are as per the standard game. Players can start the game in any year of their mutual choosing. Carrier production limit is one escort carrier (757.7-Light) and one other carrier per turn. Mauler limit is one per year; maulers can be built by any race. All races get six free fighters per year. Tug pod production is not limited. Battleships can be built by any race using [436.0] if all players agree beforehand. Rule (433.15) does not apply. ☼☼☼

## TOTAL WAR UPDATE

Well, just about nothing predicted in CL#15 actually came to pass. Advanced Operations was divided in two. *F&E Module #2: Marine Assault* is now set for Spring 95, while the "late war" expansion (X-ships, casual PFs) will be done later.

The Jindarian F&E rules were moved from F1 to Civil Wars.

We have some updated material for the various playtest rules to help you with your playtesting.

For the Survey Ships rule, the 5-point conversion produces a ship unable to carry fighters. To get the fighter-carrying version, you have to do another 2-point conversion (and pay for the fighters, of course). Speaking of the survey ships, Chris Schrader of Nova Scotia was kind enough to calculate the EW factors for all of the SRs for us.

4 EWP: Fed GSC, COV; ISC SR.

3 EWP: Gorn SR, Lyran SR.

2 EWP: Fed CLS; Klingon D6E, D7E; Romulan KER, PE; Kzinti SR; Hydran SR (1 fighter factor on non-CV Hydran SR).

Prime Teams no longer attack PDUs on their own, but now provide a +1 die-roll shift for attacks by Marines. ☼☼☼



## BALANCING FLEETS IN THE FREE CAMPAIGN

by Eric R Stork

F&E includes a detailed order of battle, but this is (for better or worse) hard-wired to the historical scenario. Those wishing to play the "free, non-historical, make your own allies" game will face considerable problems in that some races do not have fleets on certain borders. These include the Klingon-Lyrans border and the Gorn-ISC and Romulan-ISC borders. While the home fleets could be used to cover those borders, doing so would deny those races a true home fleet, which has a role as the central reserve. There is also another problem, in that the Coalition races are (in the historical scenario) all "cocked and loaded" for the grand offensive and outnumber the Alliance races' fleets on their common borders. The solution selected was to deduct ships from the historical offensive borders and use them to create new fleets on the previously unguarded frontiers. In doing so, certain conversions will have to be done, and this will (to maintain the historical position) mean that those races will technically start the game "in debt" to some extent.

### KLINGONS

The Klingons initially suffer from two problems: no border fleet with the Lyrans and other border fleets larger than their opposition. As an alternative, I suggest doing the following changes in initial fleet deployment:

North Fleet: Loses D7, D6, F5Q and entire province 0906 to Red Fleet.

East Fleet: Loses D7, D6, F5Q to Red Fleet and entire province 1707 to North Fleet.

West Fleet: Loses D7, D6, F5Q to Red Fleet.

Home Fleet: Loses 3E4, TGA, D6V Group to Red Fleet.

Red Fleet (Lyrans Border): Deploy in provinces 1008, 1011, and 0906 and BATS in 1209. Consists of D7C, 2D7, 2D6, F5L, 2F5Q, 2E4, D6M, F5S, FV Group, D6V Group, TGA. To create this fleet, you must do several conversions (D7 to D7C, D6 to D6M, F5 to F5S, F5L to FV) and substitute an E4A for an F5 to create the FV group.

These changes are done to create a Lyran border fleet without significantly reducing the Home Fleet. It also creates more balanced fleets on each border in regard to other races without reducing the other races' strength. Note provinces were shifted to accommodate the Red Fleet and give a smaller East Fleet less space to cover, even with help from the Tholian Border Squadron. The Northern and Southern reserve fleets were left intact. Unlike the other borders, the Red Fleet has no SAV since the only three available are tied to other fleets and no ships are created "magically" to balance things out, although you may give them one of Home Fleet's MBs or FRDs to compensate if you feel this is necessary. This is not thought to be a problem since Lyrans don't use fighters at start. The only problem with this is that Klingons start with a 12-point deficit and four fewer free fighters (on the first turn) to accommodate conversions in the Red Fleet. The Home Fleet is now available when any race is at war with the Klingons. While the Red Fleet's deployment area only has four BATS, they must also cover the minor planets in 1010 and 1210 and the major planet at 1112.

### LYRANS

The Lyrans have similar problems as above, no border fleet with Klingons and other border fleets larger than their opposition. Again, for the same reasons above, I suggest doing the following changes to the initial fleet deployment:

Red Claw: Loses 2CA, 2CW, 2CL, 2DD, 2FF to Foremost.

Enemy's Blood: Loses CA, CL, DD, FF to Foremost.

Home Fleet: Loses CW, DD, TGP, and deployment in 0608 and 0707 to Foremost.

Foremost Fleet: Deploy in provinces 0707 and 0709. Consists of BC, CC, 2CA, 3CW, 2CL, 3DD, 3FF, SC, TGP. To achieve this, convert CA to CC, CL to BC, DD to SC.

You now have a Klingon border fleet and more balanced fleets on the Kzinti and Hydran borders. You could also give them the Home Fleet's MB so they have one like the others, but this wasn't done since it is assumed it will be set up in the capital as a starbase to allow a second major conversion. The only real question is whether to give them the Home Fleet's Reserve marker (the decision is yours). You can also balance out more by giving the Enemy's Blood Fleet a CW from both the Red Claw Fleet and the Foremost Fleet, although the extra CL in the Red Claw Fleet has nowhere to go. The conversions would start them off with a 9-point deficit. The Foremost Fleet's deployment area may be small, but they have a large Klingon border to defend.

### ROMULANS

The Romulans need a border fleet with the ISC. Therefore, the following changes are suggested to create the Eastern Fleet with the ISC:

North Fleet: Loses 3WE, SN, SNB, KR, and province 4810 and SB in 4812 to Eastern Fleet.

West Fleet: Loses 3WE, SN, SNB, K7R to Eastern Fleet and province 4110 to North Fleet.

Home Fleet: Loses 2WE, KR, K5Q, KRT to Eastern Fleet.

Eastern Fleet: Deploy in provinces 4810, 4912, and 4813 and SB in 4812. Consists of KE, 5WE, SE, 2SN, 2SNB, FAL, KRC, KR, KRM, K5Q, KRT. To achieve this, convert WE to KE, WE to SE, K7R to KRC, KR to KRM.

The provinces are shifted to allow the smaller Western Fleet to cover a smaller sector and to give the new Eastern Fleet room to operate. This is needed because (603.15) effectively limits their southern deployment on this border. The Eastern Fleet has a small deployment area compared to the other borders, but if you have Captain's Log #13, you can see that they directly face the ISC 4th Fleet and have their work cut out for them. Finally, you could give the Home Fleet's Reserve marker to the East Fleet if you desire. The conversions cost a total of 18 points, which must be paid on the first turn.

### GORNS

The Gorns also need a fleet on the ISC border.

2nd Fleet: Loses BC, 2CL, 2DD to 3rd Fleet.

6th Fleet: Loses BC, 2CL, 2DD, and province 4906 to 3rd Fleet.

Home Fleet: Loses DD to 3rd Fleet.

3rd Fleet: Deploy in provinces 5101, 5104, and 4906. Consists of CC, BC, 4CL, 4DD, SC. Convert BC to CC, DD to SC.

The problem I encountered here is the limited and small fleet of the Gorns, and even with the fact that their ships have higher density per class, these small fleets are barely able to cover their areas. I did not "magically" create a new fleet since this would be unfair, so I worked with what I had. On a brighter note, this only starts the Gorns off with a 3-point debt.

### CONCLUSION

As you can see, each of the above races now has a new fleet to cover empty borders and other border fleets that now are closer to matching their opposition. They may not exactly match, but they are much more balanced than before. The small debts created can be paid off in the first turn without any significant effect on overall game. These changes will make the Free Campaign workable. ○○○



# TOTAL WAR PREVIEW

## (5P.0) CASUAL PF FLOTILLAS

Those races which deployed PFs (Fast Patrol Ships) assigned most of them to bases and PFTs, but some were based on standard warships fitted with "mech links" to carry them.—*Steve Cole & Tony Zbaraschuk*

### (5P.1) FLOTILLAS

**(5P.11)** Any race may deploy casual PFs during and after the third turn of that race's PF deployment schedule. [Exception: The Federation may only produce casual PFs if (502.65) is in use.] Each race is provided with four casual PF flotilla counters and cannot add more. Exception: The Lyrans, who traditionally used more casual PFs, are provided with eight.

**(5P.12)** A casual PF Flotilla is, in effect, a PFT without a PFT. It represents several standard warships fitted with mech links and given the needed supplies to maintain and operate the PFs.

**(5P.13)** These casual PF flotillas are received at no cost, but originally include no PFs. Any PFs assigned to a casual PF flotilla must be purchased by (502.2).

### (5P.2) ASSIGNMENT

**(5P.21)** Each casual PF flotilla counter is assigned to a group of ships all within the same hex (and the same fleet) but not to specific ships within the group. (A typical fleet will normally have many times the required level, making an exact count unnecessary.) Ships may join and leave the group at will without affecting the casual PF flotilla so long as enough ships remain at every instant to support the flotilla (5P.24). Unbreakable groups carrying casual PFs count as the individual ships.

**(5P.22)** Casual PF flotillas may not be assigned to or carried by PFTs, SCSs, Police ships, Federation ships, Andro ships, Aux carriers, monitors, FRDs, convoys, PDUs, or bases.

**(5P.23)** Casual PF flotillas may not be assigned to foreign or captured ships. They cannot function if not in supply.

**(5P.24)** A casual PF flotilla can contain up to six PFs. Each "ship" (5P.21) can carry a number of PFs as follows:

Ships with less than 7 factors ‡	1 PF
Romulan FAL; Gorn HDS, LTT	1 PF
Ships with 7 or more factors ‡	2 PFs
Battleships	4 PFs
Lyrans ships with 8 ‡ or more factors (not NCA)	4 PFs
Lyrans BBs, BCHs, and DNst †	6 PFs

If, at any time, there are not enough friendly ships in the same hex as the casual PF flotilla to support it, any surplus is destroyed immediately and without producing "minus points".

† Lyrans DNs, BBs, and BCHs; Romulan Condors, and Tholian BBs, can be converted to true PFTs for 3 points.

‡ Use the higher of the attack or defense factor.

**(5P.25)** Individual PFs can be transferred to and from a casual PF flotilla just as they could to or from any PFT. These PFs can come from or go to any legal tender/base of the same race.

**(5P.26)** Casual PF flotillas cannot be adopted or used in Expeditionary Forces.

**(5P.27)** No battle force can have more than one casual flotilla; Lyrans Battle forces can have two.

**(5P.28)** No pod (except PFT or SCS) can carry casual PFs. Tugs/LTTs can casual PFs only if not carrying a PFT/SCS pod.

### (5P.3) MOVEMENT

**(5P.31)** A casual PF flotilla moves with the ships which carries it. A casual PF flotilla cannot be left behind during movement, nor may the flotilla be moved separately from the ships during Reaction Movement. This is because only tenders had the necessary equipment to "flush" PF engines after long voyages.

**(5P.32)** A casual PF flotilla is counted for pinning purposes just as regular PFs are (203.54). However, casual PFs must have sufficient ships with them to support them.

**(5P.33)** When the race receives its casual PF flotilla markers (5P.11), these can be assigned to any group of ships which is in supply from the capital. If at any time a casual PF flotilla counter is empty (i.e., has no PFs assigned), the counter can be removed and reassigned to any other group of ships which is in supply from the capital.

### (5P.4) COMBAT

**(5P.41)** Casual PFs cannot be assigned to a Battle Force unless there are enough ships in that Battle Force to carry all of them; see (5P.24). Between Combat Rounds, individual casual PFs could be transferred to PFTs as per (502.45).

**(5P.42)** Each casual PF flotilla is treated, for purposes of command, as a PF flotilla operating independently of its tender and counts against the command limit.

**(5P.43)** Because of the higher maintenance costs involved, the PFs in casual PF flotillas cannot be used if they are out of supply.

## F&E COMMENTARIES

**(653.9I)** The term GSC should be SR in two places.

**(205.1)** If a Coalition stack and an Alliance stack are in adjacent hexes and the Coalition stack moves away from the Alliance stack, the Alliance stack cannot react even if the Coalition stack ends its movement after only moving 1 hex.

**(206.1)** Exception: The non-phasing player may use Retrograde Movement for those units eligible under CEDS (308.131).

**(308.83)** The starbase still requires 72 points to CRIPPLE with directed damage, not destroy.

**(308.84)** EXAMPLE: The Attacker cannot CRIPPLE it with Directed Damage unless he has the full 72 points required.

**(431.31)** Gorns can overbuild CMs.

**(439.22)** Base hull costs for Hydran salvage are as follows: 16 points for the DN classes, 10 points for BCH classes (OL), 8 points for CA and CC classes (RN, DG, LM, LB, etc.), 5 points for CW classes (HR, TR, etc.), 6 points for DD classes (KN, LN, etc.) and NCA (MHK and IRQ) classes, and 3 points for FF classes (HN, CR, etc.).

**(508.233)** Incorporating a captured planet into your supply grid is optional. In Step 1, economics are determined and the status of the captured planet is decided for the entire turn.

**(511.32)** The new shipyard can begin full production on the turn after it is paid for.

**(515.21)** The Hydran CVM is artificially classed as a "medium" carrier because the Hydrans usually operated it with 2 escorts.

**(516.33)** Confirm, the Romulan SPH is treated as a CW for purposes of (421.0), not as a LTT or TUG.

**(607.43)** May produce D6S Y160+.

**(607.44)** May produce CD any time; may produce SDF Y160+.

**Annex 702:** NCD can be subed for NCL once/year (440.2).

**Annex 703:** D5D for D5 or D6D for D6/D7 once/year (440.2).

**Annex 704:** Romulan PHX should not have the scout diamond.

**Annex 705:** CD for BC or DF for FF or MDC for CM once per year; see (440.2).

**Annex 711:** CWS can be produced at any time. This corresponds with the new annexes in Carrier War. While there are certain restrictions placed on ships for historical production in SFB, some of those don't exist in F&E. The players are allowed to make their own decisions, and suffer the consequences if wrong.

**Annex 751:** Kzinti CVL to CV . . . 5 EPs.

**Annex 757.6:** Many Hydran ships are "single ship hybrid carriers", but only those under (515.43) can be escorted. ☼☼☼







# FEDERATION (NEW) MAULER CRUISER CONJECTURAL

**CREW UNITS**

*									

**ADMINISTRATIVE SHUTTLES**

HIT POINTS	NOTES

**SHIP DATA TABLE**

TYPE = MCL  
 POINT VALUE = 128  
 BREAKDOWN = 4-6  
 SHIELD COST = 1+1  
 LIFE SUPPORT = 1  
 SIZE CLASS = 3  
 REFERENCE = R2.960  
 PLUS REFIT = +4

**BOARDING PARTIES**

**PROBES**

**TRANSPORTER BOMBS**

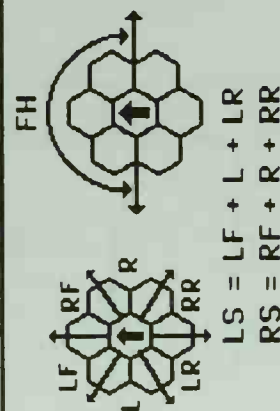
**TYPE I OFFENSIVE PHASER TABLE**

DIE ROLL	0	1	2	3	4	5	6	7	8	9	10	11	12	13	14	15	16	20	25	30	35	40	45	50	55	60	65	70	75
1	9	8	7	6	5	4	3	2	1	0	0	0	0	0	0	0	0	0	0	0	0	0	0	0	0	0	0	0	0
2	8	7	6	5	4	3	2	1	0	0	0	0	0	0	0	0	0	0	0	0	0	0	0	0	0	0	0	0	0
3	7	5	4	4	4	3	2	0	0	0	0	0	0	0	0	0	0	0	0	0	0	0	0	0	0	0	0	0	0
4	6	4	4	4	4	3	2	0	0	0	0	0	0	0	0	0	0	0	0	0	0	0	0	0	0	0	0	0	0
5	5	4	4	4	3	3	1	0	0	0	0	0	0	0	0	0	0	0	0	0	0	0	0	0	0	0	0	0	0
6	4	4	3	3	2	2	0	0	0	0	0	0	0	0	0	0	0	0	0	0	0	0	0	0	0	0	0	0	0

**TYPE III DEFENSE PHASER**

DIE ROLL	0	1	2	3	4	5	6	7	8	9	10	11	12	13	14	15
1	4	4	4	3	1	1	1	1	1	1	1	1	1	1	1	1
2	4	4	4	2	1	0	0	0	0	0	0	0	0	0	0	0
3	4	4	4	1	0	0	0	0	0	0	0	0	0	0	0	0
4	4	4	3	0	0	0	0	0	0	0	0	0	0	0	0	0
5	4	3	2	0	0	0	0	0	0	0	0	0	0	0	0	0
6	3	3	1	0	0	0	0	0	0	0	0	0	0	0	0	0

**MAULER RANGE ADJUSTMENT CHART**

RANGE	DAMAGE SCORED
0-1	Double the energy discharged
2-5	Equal to energy discharged
6-10	One-half of energy discharged

ANY POWER SYSTEM CONNECTED TO THE MAULER CAN BE DESTROYED ON "ANY WEAPON" HITS.  
 SEE (D23.0) FOR SHOCK DAMAGE.  
 SEE (E8.27) FOR ALTERNATIVE FIRING ARCS.

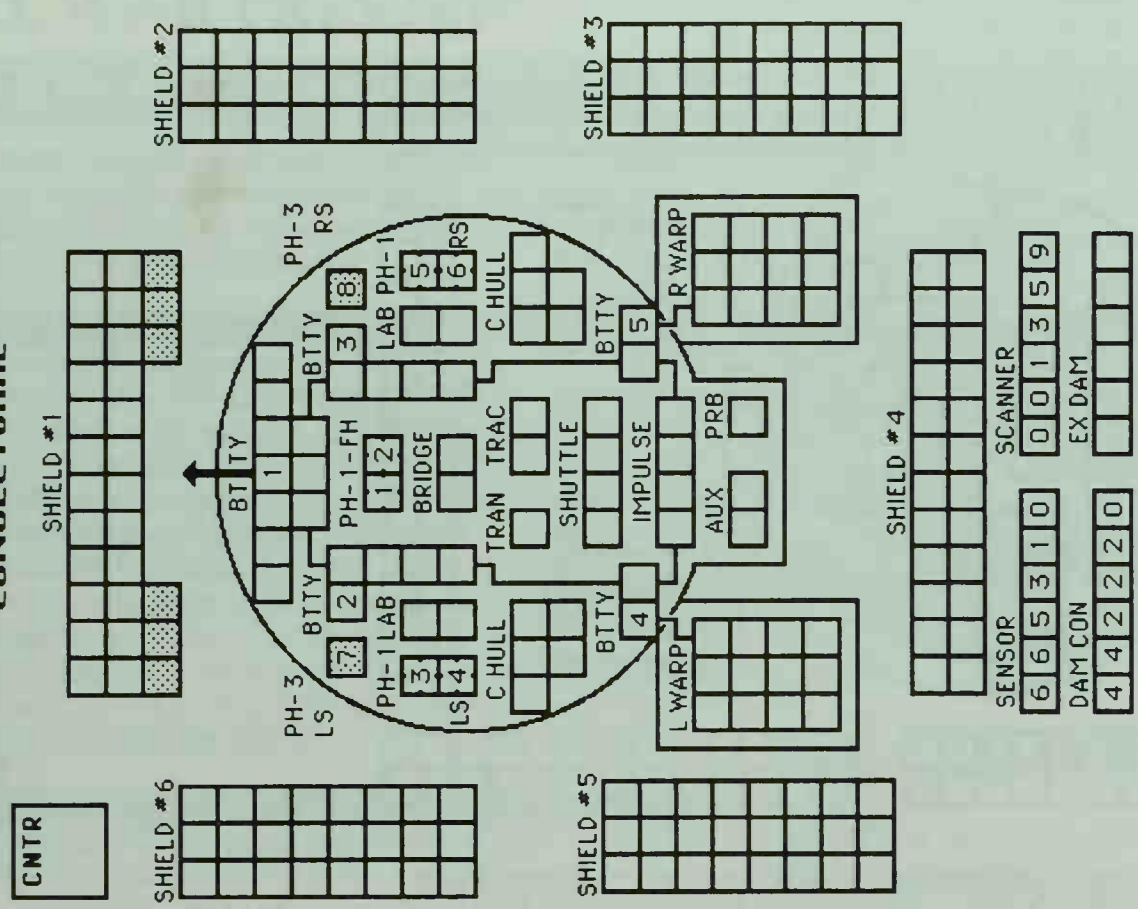

SHADED BOXES ARE THE PLUS REFIT.

**TURN MODE SPEED**

C	1	2	3	4	5	6
	2-4	5-9	10-14	15-20	21-27	28+

**HET** [ ] [ ] [ ] [ ] [ ] [ ]  
**BD** [ ] [ ] [ ] [ ] [ ] [ ]

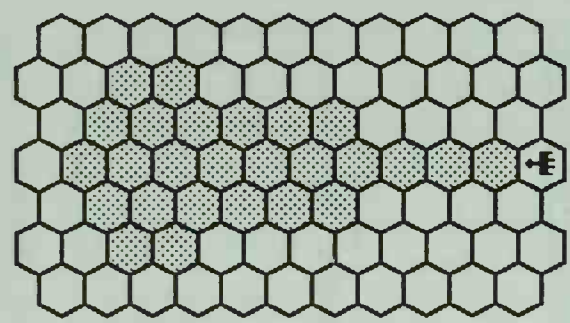

**WARP ENERGY MOVEMENT COST = 2/3 ENERGY POINT PER HEX**      **[5] = HET COST**      **[6] = ERRATIC MANEUVER WARP COST**

SPEED	1	2	3	4	5	6	7	8	9	10	11	12	13	14	15	16	17	18	19	20	21	22	23	24	25	26	27	28	29	30
Standard	1	2	2	3	4	4	5	6	6	7	8	8	9	10	10	11	12	12	13	14	14	15	16	16	17	18	18	19	20	20
Fract.	2/3	1 1/3	2	2 2/3	3 1/3	4	4 2/3	5 1/3	6	6 2/3	7 1/3	8	8 2/3	9 1/3	10	10 2/3	11 1/3	12	12 2/3	13 1/3	14	14 2/3	15 1/3	16	16 2/3	17 1/3	18	18 2/3	19 1/3	20











# GORN MEDIUM MAULER

## CONJECTURAL

CREW UNITS		ADMINISTRATIVE SHUTTLES	
*		IDENT	HIT POINTS
	10		
	20		
	30		GAS
	40		GAS
BOARDING PARTIES		THIS SHIP HAS TWO SHUTTLE BAYS	
	10	CAN TRANSFER BY (J1.59).	

PROBES	5
TRANSPORTER BOMBS	00000

TYPE I OFFENSIVE PHASER TABLE		6-	9-	16-	26-	51-
DIE ROLL	RANGE	0	1	2	3	4
1	9	8	7	6	5	4
2	8	7	6	5	4	3
3	7	5	4	4	3	2
4	6	4	4	4	3	2
5	5	4	4	3	3	2
6	4	4	3	3	2	2

TYPE III DEFENSE PHASER		4-	9-
DIE ROLL	RANGE	0	1
1	4	4	3
2	4	4	2
3	4	4	1
4	4	3	0
5	4	3	0
6	3	3	0

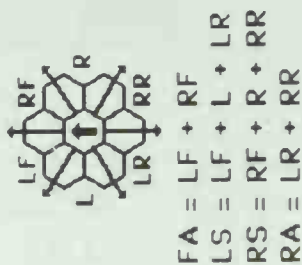

MAULER RANGE ADJUSTMENT CHART	
RANGE	DAMAGE SCORED
0-1	Double the energy discharged
2-5	Equal to energy discharged
6-10	One-half of energy discharged

ANY POWER SYSTEM CONNECTED TO THE MAULER CAN BE DESTROYED ON "ANY WEAPON" HITS.  
SEE (D23.0) FOR SHOCK DAMAGE  
SEE (E8.27) FOR ALTERNATIVE FIRING ARCS.

SHIP DATA TABLE	
TYPE	= MCM
POINT VALUE	= 173
BREAKDOWN	= 5-6
SHIELD COST	= 1+1
LIFE SUPPORT	= 1
SIZE CLASS	= 3
REFERENCE	= R6.923

SCANNER	000159
---------	--------

DAMCON	42220
--------	-------

EX DAM	
--------	--

TURN MODE	SPEED
1	2-4
2	5-8
3	9-12
4	13-17
5	18-24
6	25+

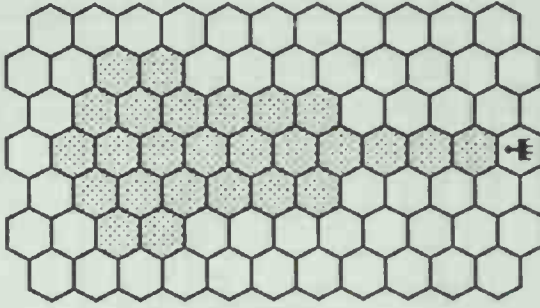

MOVEMENT COST = 1  
HET COST = 5  
EM COST = 6

CNTR	
------	--

SENSOR	66410
--------	-------

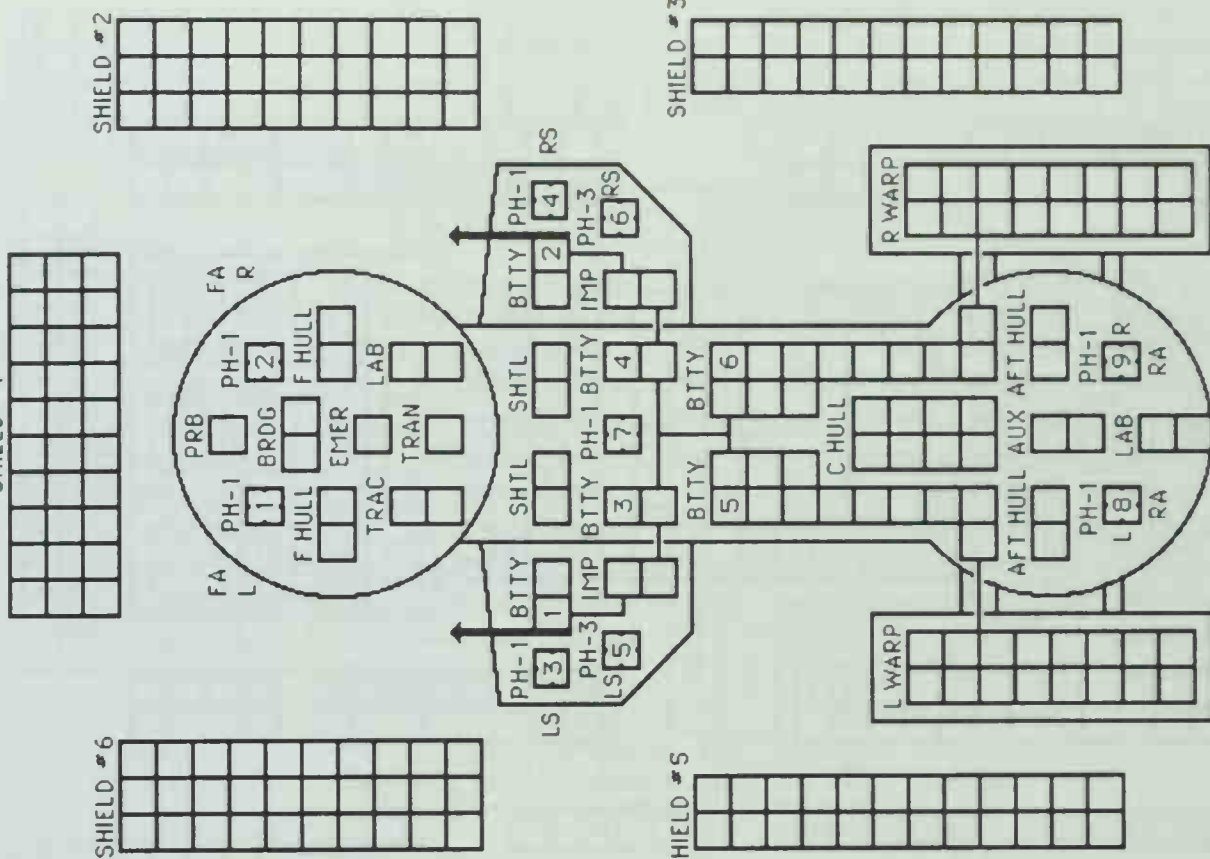

THE PH-1 IN THE CENTER HAS A 360° FIRING ARC.  
THE 360° PHASER CANNOT FIRE INTO THE HEX ROW EXTENDING DIRECTLY BEHIND THE SHIP.















# STAR FLEET BATTLES FRAX SSD BOOK



## CAPTAIN'S LOG #16

R91.08 Frax Battleship.....	2
R91.02 Frax Dreadnought.....	3
R91.09 Frax Command Cruiser.....	4
R91.03 Frax Heavy Cruiser.....	5
R91.18 Frax Carrier.....	6
R91.04 Frax War Cruiser.....	7
R91.05 Frax War Carrier.....	8
R91.06 Frax PF Tender.....	9
R91.07 Frax War Cruiser Escort.....	10
R91.10 Frax War Destroyer.....	11
R91.11-15 Frax War Destroyer Variants.....	12
R91.20 Frax Frigate.....	13
R91.19 Frax Tug.....	14
R91.25 Frax Submarine Light Cruiser.....	15
R91.PF Frax PF Flotilla.....	16

### FRAX MASTER SHIP CHART

Ship Type	G9.0 Crew	D7.0 Brdg Prts	S2.1 BPV	C6.5 Break Down	C2.12 Move Cost	J1.42 Spare Shttl	R0.6 Size Class	C3.3 Turn Mode	Rule Nbr	Year in Srvc	C13.3 Dock Pts	D5.2 Explo Str	F&E Cmnd Ratng	Notes
BB	65	26	350	3-6	2.00	2+2	2	E	8	184	36	43	10	D%, Y2, V
DN	55	20	210	4-6	1.50	2	2	D	2	167	14	31	10	
CC	45	14	153	5-6	1.00	2	3	C	9	143	10	21	9	
CA	45	14	140	5-6	1.00	2	3	C	3	122	10	19	8	
CV	45	14	140/100	5-6	1.00	2+4	3	C	18	167	10	17	8	D%, V
CW	40	10	120	5-6	0.67	2	3	B	4	168	6	16	6	
CWV	44	10	120/100	5-6	0.67	2+4	3	B	5	170	6	13	6	D%, V
PFT	40	10	120/80	5-6	0.67	2	3	B	6	179	6	13	6	P, ◆
CWE	40	10	140	5-6	0.67	2	3	B	7	170	6	16	6	E, LA
CWA	40	10	152	5-6	0.67	2	3	B	7A	175	6	16	6	E, A
DW	28	8	90	5-6	0.50	1	4	B	10	135	4	12	4	
DWD	28	8	93	5-6	0.50	1	4	B	11	137	4	12	4	
DWS	28	8	100/80	5-6	0.50	1	4	B	12	138	4	11	4	◆
DWM	28	8	100/80	5-6	0.50	1	4	B	13	168	4	11	4	MS
DWE	28	8	97	5-6	0.50	1	4	B	14	167	4	12	4	E, LA
DWA	28	8	102	5-6	0.50	1	4	B	15	175	4	12	4	E, A
DWC	32	28	109/79	5-6	0.50	1	4	B	17	155	4	10	4	T
MDW	28	8	93	5-6	0.50	1	4	B	16	170	4	12	4	B
TUG	45	10	140/80	3-6	†	2	3	†	19	124	10	17	6	TG
FF	20	6	75	5-6	0.33	1	4	A	20	121	4	9	3	
SFF	10	4	60	6	0.33	-	4	A	21	121	3	8	3	SUB
SDD	14	6	80	5-6	0.50	-	4	B	22	135	4	11	4	SUB
SCW	19	10	110	5-6	0.67	1	3	B	23	168	5	16	6	SUB
SCL	19	10	110	5-6	0.67	1	3	B	25	168	5	16	6	SUB
SCG	28	12	150	5-6	1.00	1	3	C	24	170	9	20	8	SUB, B
PF	3	1	20/30	6	0.20	-	5	AA	PF1	179	1	8	3	
PFD	3	1	20/30	6	0.20	-	5	AA	PF2	179	1	8	3	

B = Bombardment capable ship. SUB = Submarine (cloaked ship, special rules to launch when cloaked.)

Copyright © 1994 Amarillo Design Bureau. Purchasers of this product may produce a reasonable number of copies of the pages of this book for their own personal use. Reproduction for sale or other purposes is not authorized. Revised 11/14/94.































# FRAX COMMAND CRUISER

CNTR

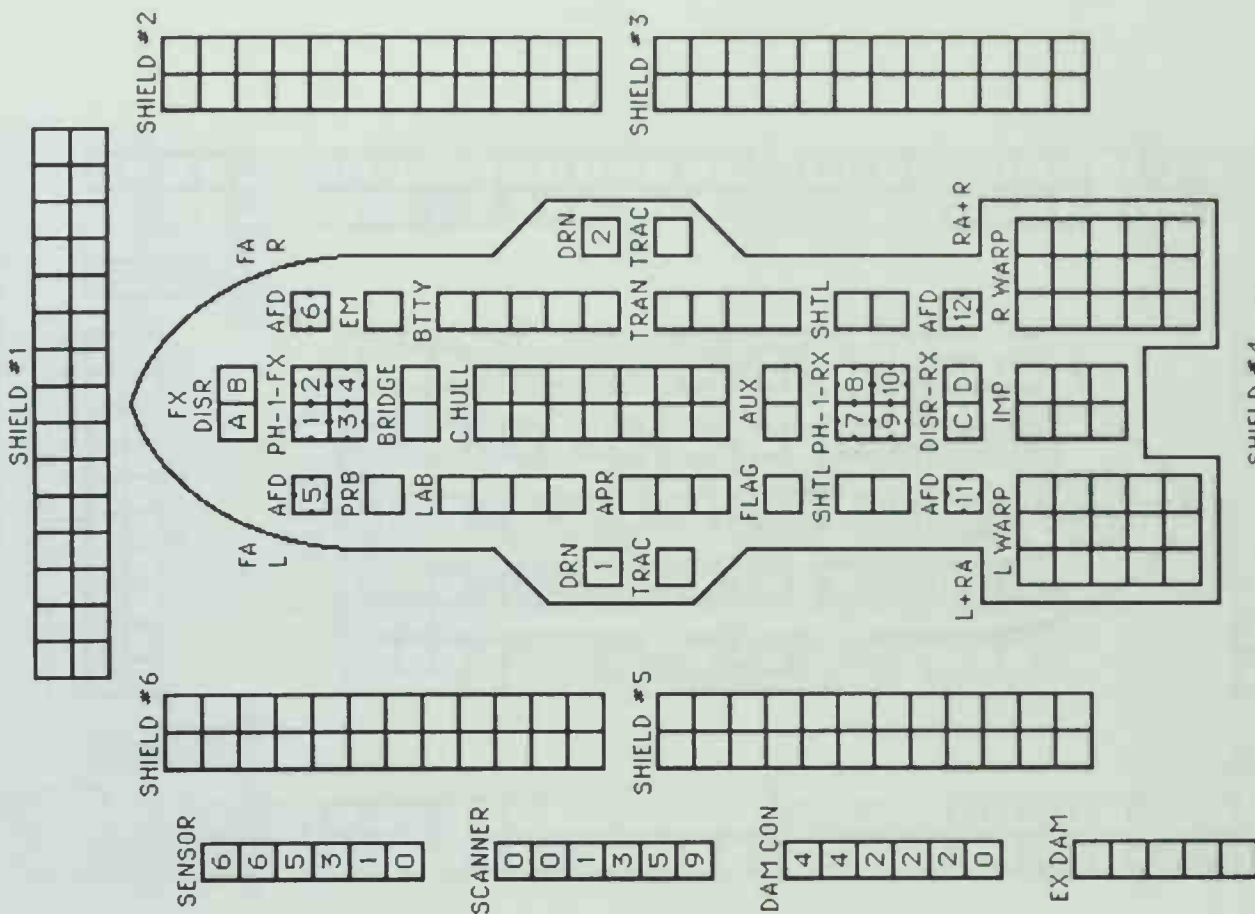

SHIP DATA TABLE	
TYPE	= CC
POINT VALUE	= 153
BREAKDOWN	= 5-6
SHIELD COST	= 1+1
LIFE SUPPORT	= 1
SIZE CLASS	= 3
REFERENCE	= R91.9
Y175 REFIT	= +0
AFD REFIT	= +8

TURN MODE	SPEED
C 1	2-4
2	5-9
3	10-14
4	15-20
5	21-27
6	28+

TYPE III DEFENSE PHASER	
DIE ROLL	RANGE
0	1 2 3 4 5 6
1	4 4 4 4 4 4
2	4 4 4 4 4 4
3	4 4 4 4 4 4
4	4 4 4 4 4 4
5	4 4 4 4 4 4
6	3 3 3 3 3 3

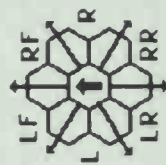

FA = LF + RF  
 RA = LR + RR  
 FX = L + LF + RF + R  
 RX = L + LR + RR + R

MOVEMENT COST = 1  
 EM COST = 6 HET COST = 5

ADMINISTRATIVE SHUTTLES		
IDENT	HIT POINTS	NOTES

CREW UNITS	
*	10
	20
	30
	40

BOARDING PARTIES	
	10

TWO SHUTTLE BAYS - NO TRANSFERS.	

TRANSPORTER BOMBS	
	D
	D
	D
	D

TYPE I OFFENSIVE PHASER/TABLE	
DIE ROLL	RANGE
0	6- 9- 16- 26- 51- 75
1	9 8 7 6 5 4 3 2 1 1 0
2	8 7 6 5 4 3 2 1 1 0
3	7 5 5 4 4 3 1 0 0 0
4	6 4 4 4 4 3 2 0 0 0
5	5 4 4 4 3 3 1 0 0 0
6	4 4 3 3 2 2 0 0 0 0

HIT & RUN DERFACS	

DRONE RACKS	
1	B
2	B

THIS SHIP HAS ONE RELOAD PRIOR TO THE Y175 REFIT, TWO RELOADS THEREAFTER.

ANTI-DRONES (AFD)	
5	
6	
11	
12	

THE SSD SHOWS THE AFD REFIT, WITHOUT THE REFIT, EACH AFD IS REPLACED BY A PHASER-3 WITH THE SAME FIRING ARC.

DISRUPTOR TABLE	
RANGE	0 1 2 3-4 5-8 9-15 16-22 23-30
HIT (STD)	NA 1-5 1-4 1-4 1-4 1-3 1-2
HIT(DEFRACS)	NA 1-5 1-4 1-4 1-4 1-3 1-3
HIT(OVERLOAD)	1-6 1-5 1-5 1-4 1-4 NA NA
DAMAGE, STD	0 5 4 4 3 3 2 2
DAMAGE, OULD	10 10 8 8 6 0 0 0



























FRAX PF FLOTILLA

<b>1</b>	<b>L</b>	<b>2</b>	<b>3</b>	<b>D</b>
<b>4</b>	<b>5</b>	<b>5</b>	<b>6</b>	<b>D</b>

Diagram showing ship layouts for various configurations. Each layout includes components like SHIELD, DRONE, BRDG, HULL, PH-1, APR, PH-3, IMP, WRP, RS, LR, LS, RR, WBP, and EX DAM. It also includes numerical values for DAM CON, SENSOR, and SCANNER.

ADMINISTRATIVE SHUTTLE	
IDENT	HIT POINTS

PF DATA TABLE	
TYPE	= PFA
POINT VALUE	= 20/30
BREAKDOWN	= 6
SHIELD COST	= 1
LIFE SUPPORT	= 0
SIZE CLASS	= 5
REFERENCE	= R91.??
LEADER BPV	= 40/50
SCOUT BPV	= 100/50
SHIELD REFIT	= +4

AA TURN SPEED	
HET	2-8
	9-16
BD	17-24
	25+
NIMBLE SHIPS	



LS = LF + L + LR  
 RS = RF + R + RR  
 FX = L + LF + RF + R  
 RX = L + LR + RR + R

TYPE I OFFENSIVE PHASER TABLE	
DIE RANGE	6-9-15
ROLL	0 1 2 3 4 5 6 7 8 9 10 11 12 13 14 15
1	9 8 7 6 5 4 3 2 1 0 0 0 0 0 0 0
2	8 7 6 5 4 3 2 1 0 0 0 0 0 0 0 0
3	7 5 4 4 4 3 3 1 0 0 0 0 0 0 0 0
4	6 4 4 4 4 3 3 2 0 0 0 0 0 0 0 0
5	5 4 4 4 4 3 3 1 0 0 0 0 0 0 0 0
6	4 4 4 3 3 2 2 0 0 0 0 0 0 0 0 0

TYPE III DEFENSE PHASER	
DIE RANGE	4-9-15
ROLL	0 1 2 3 4 5 6 7 8 9 10 11 12 13 14 15
1	4 4 4 3 1 1 1 1 1 1 1 1 1 1 1 1
2	4 4 4 2 1 0 0 0 0 0 0 0 0 0 0 0
3	4 4 4 1 0 0 0 0 0 0 0 0 0 0 0 0
4	4 4 4 3 0 0 0 0 0 0 0 0 0 0 0 0
5	4 4 3 2 0 0 0 0 0 0 0 0 0 0 0 0
6	3 3 3 1 0 0 0 0 0 0 0 0 0 0 0 0

DRONE RACKS	
3	
2	
6	
2	

DISRUPTOR TABLE	
RANGE	0 1 2 3-4 5-8 9-10
HIT (STO)	NR 1-5 1-5 1-4 1-4 1-4
HIT(OVERLOAD)	1-6 1-5 1-5 1-4 1-4 NR
DAMAGE, STD	0 5 4 4 3 3
DAMAGE, OULD	10 10 8 8 6 6 0

SPEED	1	2	3	4	5	6	7	8	9	10	11	12	13	14	15	16	17	18	19	20	21	22	23	24	25	26	27	28	29	30
Standard	1	1	1	1	1	1	1	1	1	1	1	1	1	1	1	1	1	1	1	1	1	1	1	1	1	1	1	1	1	1
Fractional	1	2	3	4	5	6	7	8	9	10	11	12	13	14	15	16	17	18	19	20	21	22	23	24	25	26	27	28	29	30



**STAR FLEET UNIVERSE**

**F&E SUBSTITUTIONS AVAILABLE BY DATE**

YEAR	FED	KLINGON	ROMULAN	KZINTI	GORN	THOL	HYDRAN	LYRAN	ISC
From Start (Y168)	CVS for CVA CVS for CA CVB for CVA TG for CA DD for NCL DN for CVA SC for NCL CL for NCL CC for DN NCD for NCL NSC for NCL FFS for FF	D6 for D7 D6D for D6 D6M for D6 D6M for D7 D6S for D6 D6V for D6 D5D for D5 D5S for D5 F5 for F5L F5S for F5 FV for F5 E4 for F5 TGA for D7 TGA for D6 TGB for D7 TGB for D6	SUP for NH SUP for CON FH for CON FH for NH FH for SUP SPB for SP SPC for SP SPF for SP SPH for SP SKB for SK SKF for SK BH for SK FAL for SP FAL for WE SE for WE WE for SP WH for BH	CV for BC CVL for BC CD for BC DF for FF SF for FF SDF for FF TGT for BC TGC for BC	CL for HD CL for BC DD for BD TG for BC BC SC for DD BDS for BD HDS for HD	CC for CA 3xPC for DN 2xPC for CA PC for DD SC for PC (If at war) CPC for 3xPC BW for PC.	HR for TR KN for TR LN for HR CR for HN CR for CU HN for CU TG for CA SC for FF NSC for CW	CL for CA DD for CW TGC for CA TGP for CA DWS for DW CWS for CW SC for DD	CS for CL TG for CA SC for DD
Y169		LTT for D5 EV for E4		DD for CM CL for CM MSC for CM CVE for CM					DL for DD
Y170		D5V for D5		MDC for CM	LSC for CL		UH for DD	LTT for CW STT for CA	CVE for DD
Y171		DV for D7		LTT for CM			CV for CA LTT for HR	CVL for CW STJ for CW	CVL for CL
Y172	DN+ for DN FV for FF				LTT for HD			CV for CA	CV for CA CVLS for CL
Y173	NVL for NCL LTT for NCL	DVS for D7	SUB for SUP	CVA for DN DWE for FF†		CVA for CA	ID for PAL NCV for CW DWF for HN‡	CVS for CA	CVS for CA
Y174		C8V for C8	SEB for SEH SEC for SEH	CMV for CM DWE for FF†	HV for HD CV for CL				
Y175	CBD for CVS CVD for CVS CVN for CVA DNG for DN NCL for NCA NVS for NCL	D5 for D5W F5 for F5W	CNV for CON FHF for FH	CVD for BC CM for NCA MVD for CM DWS for DW	HD for CM CVS for BC‡ CVA for DN‡		CVM for NCA CVE for FF HR for MHK TR for IRQ	CVA for DN‡ CW for NCA	LTT for CL HSC for CL
Y176	NVD for NCL			CVN for DN			DWS for DW		CVA for DN
Y177	BC for CA BC for DN CC for CA		SPJ for SP						
Y178		C7 for C8 C7 for D7			CC for BC	Var for CW		PFT	
Y179		C8S for C8 D7C for D7 PFT						SCS for DN	
Y180			NH for FH	BCH for DN BCH for BC CC for BC	BCH for DN BCH for BC	PFT for DD PFT	LP for PAL OV for CC OV for PAL LM for RN LB for DG PFT	BCH for DN BCH for BC CC for CA	BCV for CC CC for CA
Y181	(PFT)			SCS for CVA PFT					
Y182			PHX for CON PFT		PFT				PFT
Y183	BCJ for BC				SCS for DN				BCS for CC
Y184									SCS for CVA
Y185			TH for NH						

This chart does not include limits for substitutions/conversions (too complex) or carrier escorts (too many, standard rules anyway).  
 † Can be done once that year and not in other years. Other substitutions can be done in any subsequent year. ‡ Special Rules.





# CAPTAIN'S LOG #16

All new challenges for Star Fleet Battles, F&E, Prime Directive, Missions, and Warlord!



**NEW EXPANDED FORMAT!**  
More pages, features, and fun!

**A SENSE OF OBLIGATION:** A daring hostage rescue in Tholian space, but does the captain have his own agenda?

**DATABASE:** SFB conventions, Why?, Proposals Board, Ask Kommodore Ketrick, the Input Guide, Ten Good Questions, Command the Future, Five Examples, Battleforce 1400, Build an SFB group, and more.

**THE FRAX:** A special 16 page SSD book, many never seen anywhere before!

**TACTICS:** The Captain holds a seminar on X-Ships. Uncle Ardak provides advice. A Kzinti finds Victory at GenCon. Plus 37 new Term Papers, each a key to victory!

**EIGHT NEW SHIPS:** Four new maulers, Fed DDX, Klingon D5XD, Jindarian shipyard cruisers!

**UNIVERSE:** The Vudar in *Prime Directive*, *Star Fleet Missions* variants, Scouts in *Warlord*.

**INDEX:** Every character, story, monster, planet, and military unit in the Star Fleet Universe.

**SCENARIOS:** Stop the Jindarians! Rescue hostages from Tholian space. Intercept a convoy! There's a Q-ship inside your convoy. Take a Federation Mauler into a Nest of Andromedan Vipers! Hunt down the Klingon mauler *Siegebreaker*. Tackle a new monster: the Mulakee. Rescue a convoy from a zone where it's Hotter than Blazes. X-ships meet in

\$ .50

**FEDERATION & EMPIRE:** Allowed Substitutions Table, Fed & Enquire, 11 Tactical Notes, Balancing Fleets in the Free Campaign, Federation Warlords, Updates, PF Flotillas from Total War.



This product adds new game play situations, background material, ships, and rules for *STAR FLEET BATTLES*. You must have SFB Basic Set to use this material. Some material in this product will also require other SFB products. The material for *FEDERATION & EMPIRE* requires that game.



ISBN# 0-922335-62-1 TFG 14.95

STOCK #5712

Edited by Stephen V Cole & Steven P Petrick

Made in USA